



Bend and twist insensitive large core multimode fiber (LCMMF) for baseband and ROF in-home data transmission

C.W. Chow^{a,*}, C.H. Yeh^b, L.G. Yang^a, J.Y. Sung^a, S.P. Huang^a, Gary Chou^c, C.L. Pan^d

^a Department of Photonics and Institute of Electro-Optical Engineering, National Chiao Tung University, Hsinchu 30010, Taiwan

^b Information and Communications Research Laboratories, Industrial Technology Research Institute, Chutung, Hsinchu 31040, Taiwan

^c Prime Optical Fiber Corporation (POFC), Chu-Nan, Miao-Li County, Taiwan

^d Department of Physics and Institute of Photonics Technologies, National Tsing-Hua University, Hsinchu, Taiwan

ARTICLE INFO

Article history:

Received 28 October 2012

Received in revised form

20 November 2012

Accepted 2 December 2012

Available online 8 January 2013

Keywords:

Large-core multimode fiber (LCMMF)

Wired and wireless access network

Orthogonal frequency division

multiplexing (OFDM)

ABSTRACT

To extend the fiber access network into the home, using optical fiber is a good choice. Bend and twist insensitive optical fiber with a large core diameter is particularly attractive, since it is easy to install and connectorize. However, its bandwidth will be severely limited by its large multimodal dispersion. Here, we first reported the design and fabrication of a novel bend and twist insensitive, 80- μm core-diameter large-core multimode fiber (LCMMF) for in-home data communication. We experimentally demonstrated 10 Gb/s multiple bands data transmission at distances for residential buildings and data centers. The bit-error-rate (BER) performances of the LCMMF under bending and twisting were evaluated. Finally, we also discovered experimentally an important relation between the differential-mode-delay (DMD) and the BER of the fabricated LCMMF. This relationship could be a valuable tool for fiber manufacturers.

© 2012 Elsevier B.V. All rights reserved.

1. Introduction

Fiber-to-the-home (FTTH) has already been deployed in many different countries and has reached the doors of many homes. To further extend it into the home, optical fiber is also a good choice [1]. Optical fiber provides the advantages of low cost, low loss, high bandwidth, small size, insensitive to electromagnetic interference when compared with copper-based cables. Furthermore, optical fiber provides the extra dimension of wavelength, which allows the integration of different types of broadband services. Bend and twist insensitive optical fiber with a large core diameter is particularly attractive, since it is easy to install and connectorize. For the applications in end-user devices, the wear and tear of the optical cables is unavoidable. This may produce optical-coupling misalignment between the laser source and the optical cables, and increasing the coupling loss. Hence the optical fiber with a large core diameter will have higher misalignment tolerance. However, its bandwidth will be severely limited by its large multimodal dispersion.

Recently different designs of optical fibers have been used in optical communications [2–4]. Besides, several approaches have been proposed to reduce the bend loss, e.g., using hole-assisted fiber [3], or nano-engineered ring structure [4]. Besides, using

multimode fiber for the transmission of radio-over-fiber (ROF) signal is becoming more and more popular [5,6] and could be as important as the transmission of baseband signal. In this work, we first report the design and evaluation of a novel bend and twist insensitive, 80- μm core-diameter large-core optical fiber (LCMMF) for in-home data communication. Our measurement results show that although the core diameter is increased by 60% when compared with typical multimode fiber (MMF) (from 50- μm to 80- μm), 10 Gb/s multiple bands data transmission at distance of 200 m required by typical building and data center applications can be achieved in this new type of LCMMF. The bit-error-rate (BER) performances under bending and twisting are evaluated. Finally, we also discover experimentally an important relation between the differential-mode-delay (DMD) and the BER of the fabricated LCMMF. This relationship could be a valuable tool for fiber manufacturers

2. Design and fabrication of the new-type 80- μm LCMMF

As the target of the LCMMF is for the modern-day applications, it requires high mechanical strength than conventional telecommunication optical fiber. In order to increase the mechanical bending strength and reduce the water erosion, a polymer-coat is applied at the outside cladding layer. This is known as the GGP (Glass–Glass–Polymer) design developed by the 3M Corporation [7]. We have been manufacturing the GGP fiber (licensed

* Corresponding author. Tel.: +886 3 5712121x56334.

E-mail address: cwchow@faculty.nctu.edu.tw (C.W. Chow).

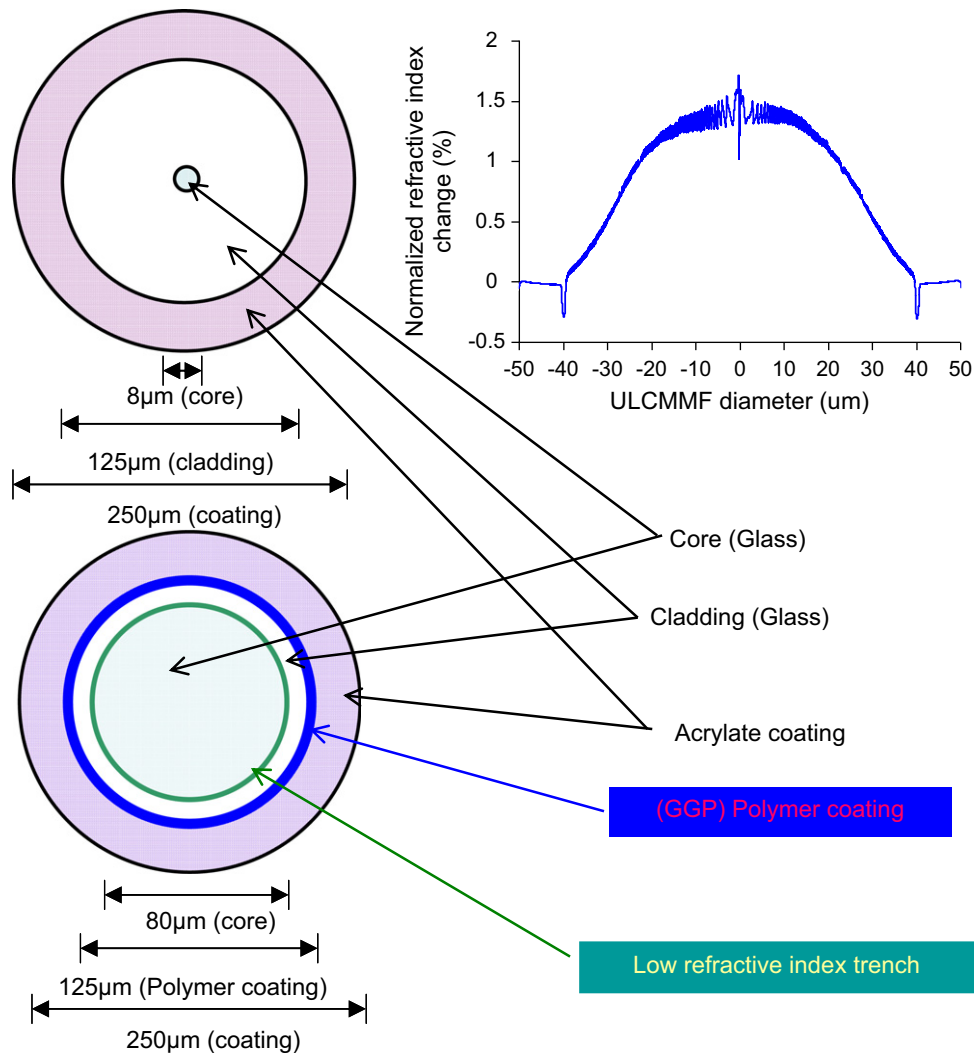

Fig. 1. Cross-section schematics of the conventional fiber and our designed and fabricated LCMMF. Inset: LCMMF refractive index profile.

by 3M). In the hot-water bending fatigue evaluation, the fabricated fiber with and without GGP were inset into 90 °C hot water with bend diameter of 3.5 mm. The fiber breaking time was detected by an acoustic sensor. At 50% failure probability, the average fiber breaking time can be greatly extended from 90.5 s (without GGP) to 124,000 s (with GGP). This was 1370 times longer lifetime, and this design does not affect the optical characteristics of the optical fiber.

Apart from the GGP structure, a low refractive index layer was applied to the LCMMF. Modified chemical vapor deposition (MCVD) was used to deposit a relatively thick layer of SiF₄ (silicon tetrafluoride, refractive index=1.4162) between the fiber core and cladding, as shown in Fig. 1. The SiF₄ was commonly used to lower the refractive index in standard optical fibers [8]. The SiF₄ doped fiber passed the standard water immersion test and damp heat test. However, by using the MCVD, the silica should be heated to near its melting point. And the timing control for making the preform was very critical since prolonged heating will create defect to the LCMMF preform. Besides, as the developed core/cladding ratio in this LCMMF is ~0.8, which is much larger than that in traditional MMF (core/cladding ~0.6). In this case, we started with a thinner silica tube for the preform fabrication. Hence the processing time can be reduced. By optimizing the MCVD process as well as using a thinner silica tube, the 80-μm LCMMF has been successfully fabrication.

We also measured that the low refractive index layer can be grown at 2 μm thick and the refractive index can be decrease by -0.3% when compared with the cladding layer (inset of Fig. 1). Later bend and twist evaluations show that this layer is good enough for making the LCMMF bend and twist insensitive. In the 1-km ULCMMF sample, the numerical aperture (NA) is 0.28, the measured core, cladding, polymer and acrylate coating diameters are 81.3-μm, 114.6-μm, 124.1-μm and 243.8-μm, respectively. The core, cladding and polymer and acrylate coating non-circularity are 2.43%, 0.21%, 0.28% and 0.6%, respectively. The attenuations at 850 nm, 1300 nm and 1550 nm are 4.64 dB/km, 2.21 dB/km and 0.57 dB/km, respectively.

3. Wired and wireless transmission, results and discussion

Fig. 2 shows the experimental setup using the LCMMF for carrying baseband and radio-over-fiber (ROF) signals. The baseband 10 Gb/s non-return-to-zero (NRZ) signal was generated from a 850 nm vertical-cavity surface-emitting laser (VCSEL) based transmitter (Tx) connected to a bit-error-rate tester (BERT). The Tx used was a commercially available 850 VCSEL SFP+ transceiver (OPLINK, TPP1XGDS0xG) with VCSEL active area diameter smaller than the fiber (center launching). Direct modulation of the VCSEL was used. The pseudo-random binary sequence (PRBS)

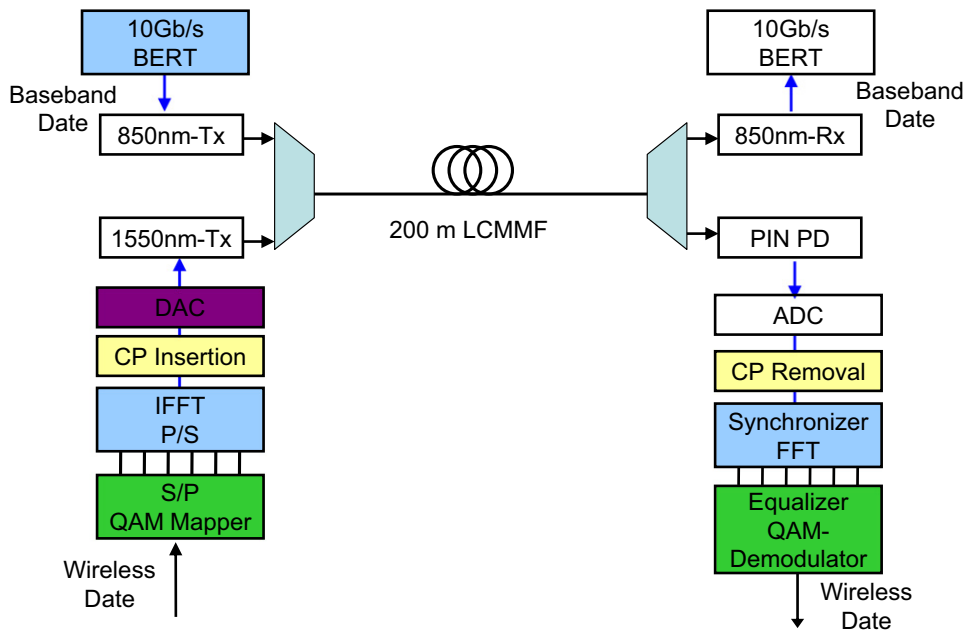

Fig. 2. Experimental setup of using the LCMMF for carrying baseband and ROF signals.

length was $2^{31} - 1$. Then the optical signal was coupled into the 200 m LCMMF before being received by the 850 nm receiver (Rx). On the other hand, the ROF signal was an orthogonal frequency division multiplexed (OFDM) signal at wavelength of 1550 nm generated by using external modulation. The light was coupled from standard single mode fiber (SMF) to the LCMMF using center launching. The OFDM signal was applied to a Mach-Zehnder modulator (MZM) using an arbitrary waveform generator (AWG). The OFDM signal processing consisted of serial-to-parallel conversion, symbol encoding, inverse fast Fourier transform (IFFT), cyclic prefix insertion (CP). The AWG acted as the digital-to-analog convertor (DAC), with sampling rate and resolution of 12 GSamples/s and 8 bits, respectively. 16 Quadrature amplitude modulation (QAM) was used in each subcarrier of the OFDM signal. The 10 Gb/s OFDM signal used in the experiment occupied ~ 2.5 GHz bandwidth (from 1.95 MHz to 2.50 GHz).

The evaluation of the baseband NRZ signal was measured directly by the BERT. The ROF OFDM signal was received by a PIN photodiode (PD) and captured by a digital real-time oscilloscope with the 50 GSamples/s sampling rate and 3 dB bandwidth of 12.5 GHz for OFDM signal demodulation. Off-line computer program was employed for the demodulation, including synchronization, fast Fourier transform (FFT), one-tap equalization, and QAM symbol decoding. The FFT size was 512. Finally the BER of the OFDM signal was obtained based on the measured signal-to-noise ratio (SNR) [9]. Fig. 3(a) and (b) shows the measured BER performances of the 10 Gb/s baseband NRZ signal and the 10 Gb/s ROF OFDM signal with the corresponding eye-diagrams and 16-QAM constellation diagrams. Negligible power penalty can be observed in both signals. The measurement results confirmed that although the core diameter is increased by 60% (from 50- μm to 80- μm), 10 Gb/s multiple bands transmission at typical home application distance can still be achieved in this new type of LCMMF. The BER performances of the 10 Gb/s baseband NRZ signal and the 10 Gb/s ROF OFDM using standard MMF were also included as a reference.

Then, we tested the bend and twist performances of the LCMMF. For the bend test, the LCMMF was wrapped around a

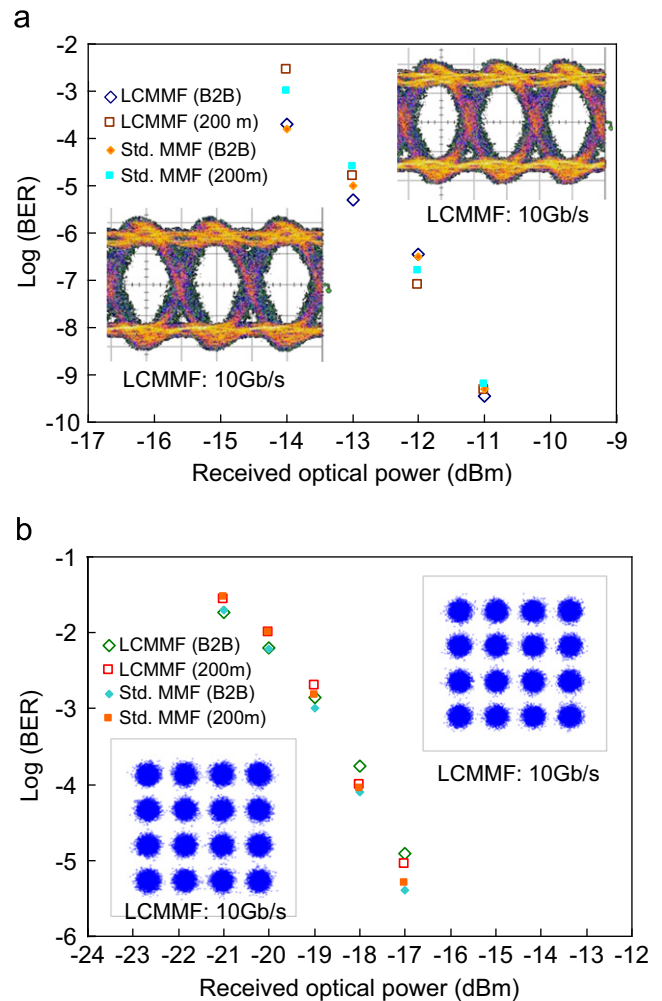

Fig. 3. Measured BER performances of the (a) 10 Gb/s baseband NRZ signal and the (b) 10 Gb/s ROF OFDM signal.

1 cm diameter steel mandrel. And the bend loss was measured at different number of turns. Fig. 4 shows the measured LCMMF bend optical power loss. We also compared the LCMMF with typical standard single mode fiber (SSMF) and typical MMF (50/125) available in the laboratory, showing that the bend loss of the LCMMF was less than 0.03 dB in 10 turns of the mandrel. For the twist testing, a section of LCMMF was fixed at both ends and it was twisted at different angles. Fig. 5(a) and (b) shows the bend and twist BER performances of the LCMMF using NRZ signal at wavelength of 850 nm. The input optical power to the Rx was -11 dB m. No measurable BER degradation was observed in both evaluations. Same results also obtained using OFDM signal at 1550 nm.

A theoretical calculation about the core size of the MMF using commercially available software VPI Transmission Maker V. 7.5 was performed. In this calculation, an input Gaussian optical

pulse with initial pulse-width (-10 dB pulse-width) of 46 ps was center launched into the standard 50- μm MMF and the 80- μm LCMMF. We used the built-in MMF model in the VPI. The optical pulse-width broadening against different fiber transmission lengths was studied and is shown in Fig. 6. The simulation results showed that the LCMMF produces higher pulse broadening due to the larger core size, and the performance is good enough for 100 m in-home data communication.

We also theoretical studied the optical pulse-width broadening against different offset launchings in the 1 km standard

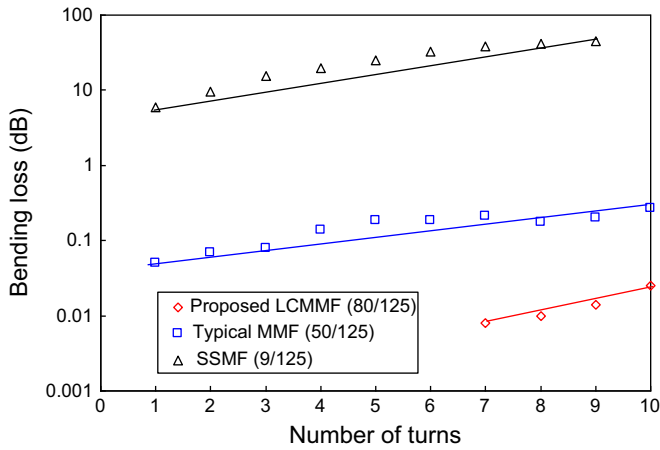

Fig. 4. Measured bend loss of the LCMMF.

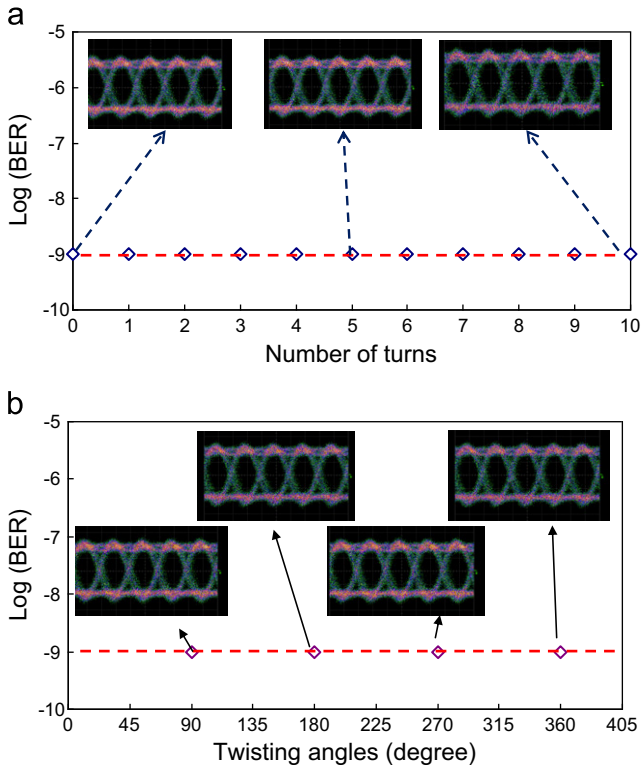

Fig. 5. Measured (a) bend and (b) twist BER performances of the LCMMF.

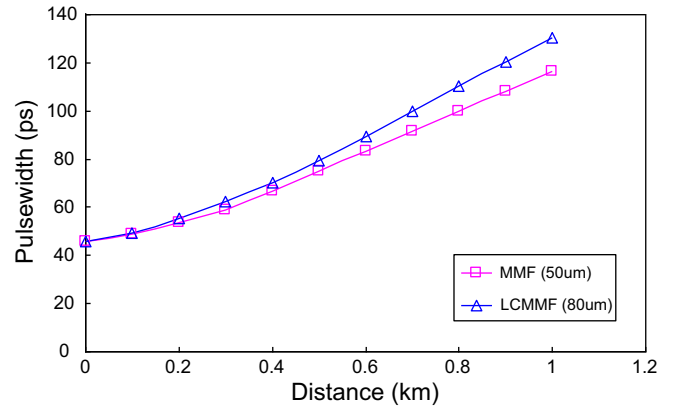

Fig. 6. Simulated optical pulse-width broadening against different fiber transmission lengths for standard MMF and the LCMMF.

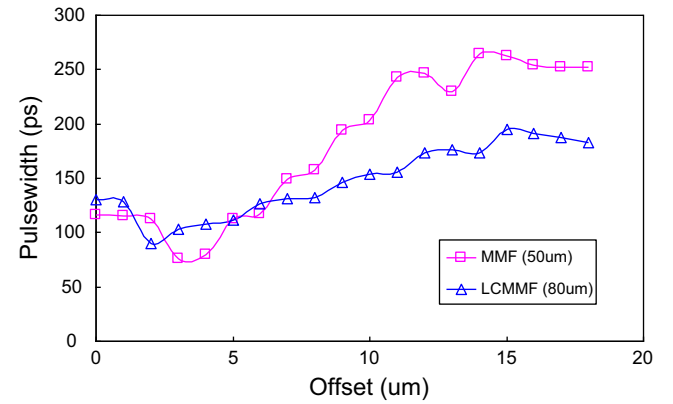

Fig. 7. Simulated optical pulse-width broadening against offset launching for the standard MMF and the LCMMF.

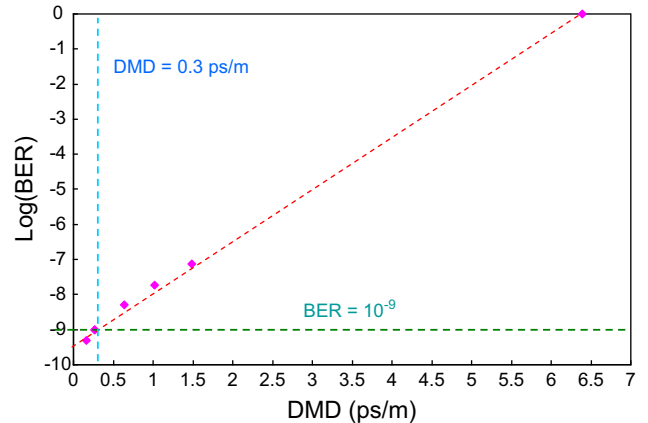

Fig. 8. Measured relationship between DDM and BER of the LCMMF.

50- μm MMF and the 1 km 80- μm LCMMF as shown in Fig. 7. We can observe that the pulse can be compressed or broadening at different offsets, similar to the studies reported in Ref. [10]. According to the simulation results, larger offset angle is desirable for the LCMMF when compared with the standard 50- μm MMF. Fig. 8.

4. Relationship between DMD and BER of the LCMMF

The DMD is an industrial standard to measure the MMF maximum difference between the delays of optical pulse propagating in one mode group compared to the other [11]. It is a fast estimation method of the fiber bandwidth and is widely adopted in fiber manufacturing industries. On the other hand, BER measures the (number of bits in error)/(total number of bits transmitted). It is the most accurate method to evaluate the performance of the fiber link. It is very important to know the BER performance of the fiber since modern applications are mainly transmitting digital data, and only using DMD for performance estimation is not sufficient. Here, we looked for a relationship between the DMD and BER performance of the LCMMF. Measurements were performed using 6 diverse LCMMF samples (with different refractive index profiles). The BER results was taken at Rx power of -11 dB m using NRZ at wavelength of 850 nm. As shown in Fig. 6, we discovered that in the fabricated LCMMF samples, when DMD is ≤ 0.3 ps/m, the BER can be $\leq 10^{-9}$. It is worth to note that the suggested criteria is only applied for NRZ modulation.

5. Conclusion

We first proposed and demonstrated the design and fabrication of a new-type bend and twist insensitive, 80- μm core-diameter LCMMF for in-home data communication. GGP and low refractive index trench were used to increase the mechanical strength and decrease the bend loss, respectively.

Multiple bands optical signals (using 10 Gb/s NRZ baseband and 10 Gb/s OFDM-16 QAM ROF signals) at 200 m transmission (suitable for in-building and data-center applications) can be achieved in this new type of LCMMF without power penalty even though the core diameter is increased by 60% (from 50- μm to 80- μm). Finally, we also discovered experimentally an important relation between the DMD and the BER of the fabricated LCMMF. This relationship could be a valuable tool for fiber manufacturers.

Acknowledgement

This work was supported by the National Science Council, Taiwan, R.O.C., under Contract NSC 100-2221-E-009-088-MY3, NSC 101-2628-E-009-007-MY3.

References

- [1] A.M.J. Koonen, Y. Shi, N.C. Tran, C.M. Okonkwo, H.P.A. van den Boom, E. Tangdiongga, "A Perspective from Europe on in-Home Networking," Proceedings OFC, 2012, Paper NTh1D.1.
- [2] K.K. Chow, K. Kikuchi, T. Nagashima, T. Hasegawa, S. Ohara, N. Sugimoto, Optics Express 15 (2007) 15418.
- [3] M. Yan, P. Shum, J. Hu, Optics Letters 30 (2005) 465.
- [4] M.-J. Li, P. Tandon, D.C. Bookbinder, S.R. Bickham, M.A. McDermott, R.B. Desorcie, D.A. Nolan, J.J. Johnson, K.A. Lewis, J.J. Englebert, Journal of Lightwave Technology 27 (2009) 376.
- [5] H.-H. Lu, G.-L. Chen, Y.-W. Chuang, C.-C. Tsai, C.-P. Chuang, Optics Communication 266 (2006) 495.
- [6] H.-H. Lu, P.-C. Lai, W.-S. Tsai, IEEE Photonics Technology Letters 16 (2004) 1215.
- [7] US Patent No.: US 6,587,628 B1.
- [8] C. DeCusatis, Handbook of Fiber Optic Data Communication: A Practical Guide to Optical Networking, third ed., Academic Press, 2008.
- [9] C.W. Chow, C.H. Yeh, C.H. Wang, F.Y. Shih, S. Chi, IEEE Photonics Technology Letters 21 (2009), vol. 715-717.
- [10] L. Raddatz, I.H. White, D.G. Cunningham, M.C. Nowell, Journal of Lightwave Technology 16 (1998) 324.
- [11] P.F. Kolesar D.J. Mazzaresse, Understanding multimode bandwidth and differential mode delay measurements and their applications, in Proceedings of the 51st International Wire and Cable Symposium of IWCS Inc., Lake Buena Vista, FL, 453 460, 2002.