

國立交通大學

資訊科學與工程研究所

碩士論文

以抽樣激發配合線性預測所設計的畫面內視訊編碼法

Excitation-based Linear Prediction for

Intra-Frame Video Coding

研究生：游瑋玲

指導教授：蔡淳仁 教授

中華民國九十九年六月

以抽樣激發配合線性預測所設計的畫面內視訊編碼法

Excitation-based Linear Prediction for
Intra-Frame Video Coding

研究生：游瑋玲

Student : Wei-Ling Yu

指導教授：蔡淳仁

Advisor : Chun-Jen Tsai

國立交通大學

資訊科學與工程研究所

碩士論文



Submitted to Institute of Computer Science and Engineering

College of Computer Science

National Chiao Tung University

in partial Fulfillment of the Requirements

for the Degree of

Master

in

Computer Science

June 2010

Hsinchu, Taiwan, Republic of China

中華民國九十九年六月

Abstract

In this thesis, we propose a new intra-prediction method for very high quality image coding. Unlike many new image coding standards, such as the intra coder of AVC/H.264 or JPEG-XR, which apply 2-D spatial predictions to remove correlation in image data, the proposed technique converts 2-D image signals to 1-D signal using Hilbert curve scan patterns before predictive coding. A linear filter is used to estimate the predictor of the 1-D signal. The prediction errors are non-uniformly down-sampled using a closed-loop optimization process, and used as the excitation signal of the predictor model. The predictor can then be constructed by using a synthesis filter and the coded excitation signal. The error residuals between the original image signal and the reconstructed predictor is then computed and coded into image bitstreams.

For residual coding, 1-D integer cosine transform is used to further compact the energy in residuals. After transform coding, arithmetic coding on the predictor description and the residuals are applied. From the experiments, the proposed intra-prediction method has much better prediction quality compares to the intra prediction method in AVC/H.264. In particular, the technique performs well for image areas with complex repeated textures. Since current CAVLC/CABAC coders in H.264 are not suitable for very high bitrate coding, some modifications of CABAC is also proposed in this thesis to improve entropy coding efficiency.

The proposed intra-coding method is integrated into JM16.1, the reference implementation of AVC/H.264, as a new coding mode and the experimental results shows that the proposed techniques are very promising for future applications.

Acknowledgement

I am heartily thankful for my adviser, Professor Chun-Jen Tsai, who guides me to understand this subject and also encourage me whenever I encounter obstacles. His wide knowledge and logical way of thinking have been of great value for me.

I warmly thank Y.C. Sun for his valuable advices and friendly help. I also wish to thank my friends. Thank you for cheering me up.

Lastly, I owe my loving thanks to my family. They always support my interest and always accompany me. Without their encouragement and understanding it would be impossible for me to finish my research.



Content

Chapter 1. Introduction.....1

Chapter 2. Previous Work4

- 2.1. Overview of image coding.....4
- 2.2. Design examples of image coding standard.....4
 - 2.2.1. JPEG image coder.....5
 - 2.2.2. H.264 intra coder6
- 2.3. Signal predictions in speech codecs.....10

Chapter 3. Proposed Intra Coding Method.....13

- 3.1. Intra Prediction Block Diagram.....14
- 3.2. Preprocessing14
 - 3.2.1. Hilbert scanning.....14
 - 3.2.2. Segmentation.....15
 - 3.2.3. Increase bit depth of signal16
- 3.3. Mode decision.....17
- 3.4. Linear prediction (Analyzer).....17
- 3.5. Synthesizer.....18
- 3.6. Excitation sampling19
- 3.7. Quantization.....22
 - 3.7.1. Linear prediction coefficient.....22
 - 3.7.2. Maximal excitation23
 - 3.7.3. Excitation value23
- 3.8. Predictor entropy coding.....24
 - 3.8.1. Segmentation mode.....24
 - 3.8.2. Excitation position24

Chapter 4. Proposed Residual Coding26

- 4.1. Transform coding26
- 4.2. Entropy coding in H.264.....27
 - 4.2.1. CAVLC27
 - 4.2.2. CABAC.....28
 - 4.2.3. Issues of CAVLC/CABAC in H.26430
- 4.3. Proposed modification in CABAC31

Chapter 5. Implementation	34
5.1. Coding structure.....	34
5.2. Prediction bitrate.....	35
Chapter 6. Experimental Results.....	37
6.1. Subjective predictor quality	37
6.2. Predictor bitrate and predictor quality	38
6.3. Performance comparisons.....	39
Chapter 7. Conclusions and Future Work.....	42
References	43

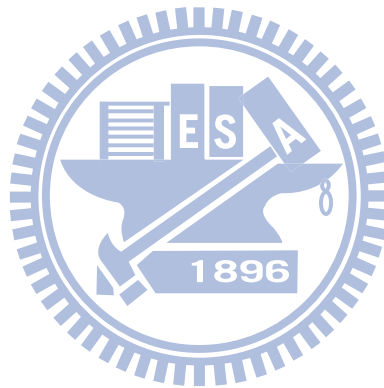

List of Figures

Fig. 1 DCT-based encoder processing steps	5
Fig. 2 lossless mode encoder processing steps	6
Fig. 3 H.264 encoder	7
Fig. 4 4x4 intra block prediction modes	10
Fig. 5 16x16 intra block prediction modes	10
Fig. 6 LPC-based speech decoder	11
Fig. 7 CELP speech encoder	12
Fig. 8 proposed intra prediction structure	14
Fig. 9 Hilbert curve	15
Fig. 10 scan 2-D image to 1-D signal	15
Fig. 11 segmentation example	16
Fig. 12 direct form realization of analyzer	18
Fig. 13 comparison between luma residual bitrate and LPC order	18
Fig. 14 direct form realization of synthesizer	19
Fig. 15 residual distribution of H.264 intra coding and RPE-based method ..	21
Fig. 16 closed-loop encoder (analysis by synthesis)	21
Fig. 17 residual distribution of irregular excitation selection and modified the excitation value properly	21
Fig. 18 implementation of lattice structure of all-pole filter (top) and all-zero filter (bottom)	23
Fig. 19 binarization of excitation position	25
Fig. 20 zigzag scan	28
Fig. 21 example of arithmetic coding	29
Fig. 22 CABAC encoder block diagram	30
Fig. 23 flower.cif bitrate saving	32
Fig. 24 mobile.cif bitrate saving	33
Fig. 25 foreman.cif bitrate saving	33
Fig. 26 encoding flowchart	35
Fig. 27 mobile: left figure is our proposed predictor, 23.6dB; right figure is H.264 intra predictor, 17.9dB	37
Fig. 28 flower: left figure is our proposed predictor, 23.4dB; right figure is H.264 intra predictor, 16.7dB	38
Fig. 29 Stefan: left figure is our proposed predictor, 25.9dB; right figure is H.264 intra predictor, 19.8dB	38
Fig. 30 foreman: left figure is our proposed predictor, 28.6dB; right figure is H.264 intra predictor, 27.6dB	38

Fig. 31 flower, mobile coding performance.....40
Fig. 32 stefan, foreman coding performance40
Fig. 33 baboon, Lena coding performance41



List of Tables

Table 1 ratio of intra blocks in inter-frame (average video quality at 44dB)...	2
Table 2 segment length	16
Table 3 bitrate comparison of CAVLC and CABAC.....	32
Table 4 bitrate allocation of proposed intra prediction.....	36
Table 5 header cost of proposed intra prediction.....	39
Table 6 average intra predictor quality (dB).....	39



Chapter 1. Introduction

Media compression is one of the key technologies for rich-multimedia applications. Although motion picture coding have been the focus of source coding researches for the past decades, there are many new reasons that call for more advanced still image coding techniques.

First of all, as visually lossless coding becomes a common requirement for HD or Ultra-HD video sequences, there will be more macroblocks coded in intra or raw PCM modes. For example, **Table 1** shows the ratio of intra macroblocks in inter-frame for some high quality video sequences, encoded by AVC/H.264 reference software JM 16.1. This ratio will be increased when the object has large motion or complex texture, such as the MPEG HD test sequences Rush_Hour and River_Bed. Since the quality of inter-coded macroblocks also depends on these intra-coded macroblocks, intra coding efficiency becomes a key factor for high quality video applications. Secondly, for video studio editing and archiving applications, intra-only video coding has always been a preference since it facilitates non-linear editing and causes less image processing and editing distortions than complex inter-frame video coding techniques. Thirdly, transfer of uncompressed raw video data across hardware system buses or transmission cables is becoming expensive as the video resolution increases towards ultra-HD (8K×4K) format. Traditional practices to solve this problem is to apply chroma-channel sub-sampling (e.g. YC_BC_R 4:2:0) or interlacing sub-sampling. However, these sub-sampling techniques are not acceptable for super high quality video sequences. To fulfill this application requirement, some technical requirement proposal has been submitted to ISO/IEC MPEG organization to request for a new standard for a low-complexity, fixed rate intra-only video coding standard

[32].

video sequence	ParkJoy	DucksTakeOff	Rush_Hour	River_Bed
	1920x1088	1920x1088	1920x1088	1920x1088
intra in inter ratio	14.6%	15.3%	80.5%	100%

Table 1 ratio of intra blocks in inter-frame (average video quality at 44dB)

Although spatial prediction tool in AVC/H.264 increases efficiency of intra coding significantly, it does not work well for macroblocks with complex textures.

In this thesis, we try to design a new intra codec that adopts a new mathematical model for prediction with the following characteristics:

- The coding process requires very little coding buffer. For some of the near-lossless applications mentioned above, coding buffer is an expensive resource. For example, for near lossless video transport across system buses and cables, it would be too expensive to include large coding buffer on the sender-side and the receiver-side. Preferably, there is an option to perform scanline-based linear coding/decoding without any buffer.
- The codec complexity is low and the operations can be parallelized without much efficiency loss. Sequential coding algorithms may access more reconstructed information to achieve higher prediction accuracy, it cannot be parallelized. For applications that requires high coding throughput, this may be an issue.
- The codec is targeted for very high quality video applications. With the development of new generations of display systems, high quality video content is becoming more and more important. As shown in **Table 1**, when video quality reaches 44dB (or above), intra coding becomes more important. For low bitrate applications, one cannot allocate too many bits to predictor description. However, when the bit rate becomes higher, the

design philosophy may change and allows for more overhead in predictor description to reduce overall coding distortion.

- Fixed compression ratio can be achieved without complex rate control algorithms. Again, some applications require strict constant bitrate of the compressed content (i.e. fixed compression ratio throughout the whole sequence). However, with traditional video compression techniques fixed compression ratio is very hard to accomplish with single-pass rate control algorithm, if possible. However, multi-pass rate control algorithm requires large coding buffer and high complexity. This makes it very difficult to design in-circuit real-time compressor and decompressor. With fixed compression ratio, video data can be transmitted in fixed clock cycles and transmission delay can also be controlled precisely, which is ideal for near-lossless raw video transmission over system buses or cables.

The organization of the thesis is as follows. Chapter 2 conducts a survey on existing image coding techniques and presents the design of two most popular intra coding standards, namely the JPEG image codec and the AVC/H.264 intra codec. Chapter 3 presents the framework of the proposed one-dimensional intra codec with excitation-based prediction. The coding of residual signals is discussed in Chapter 4. Integration of the proposed image codec into H.264 video codec is described in Chapter 5 and some experimental results are given in Chapter 6. Finally, some conclusions and discussions are given in Chapter 7.

Chapter 2. Previous Work

In section 2.1, many image coding methods are briefly described. The popular still image coding standard (JPEG and JPEG2000) are illustrated in section 2.2. AVC/H.264 intra codec is also introduced. Due to advanced spatial prediction tool, AVC/H.264 intra codec outperforms both JPEG and JPEG 2000 for general image coding. In section 2.3, some speech codecs are presented.

2.1. Overview of image coding

There are many different image coding algorithms. Different transform coding methods are developed, such as discrete cosine transform and wavelet transform. In [1], they introduce a new approach to image compression based on decomposing the image using the orthogonal wavelet transform. From the analysis of these transform codecs, wavelet transform outperforms 1dB than DCT in still image coding, but it is less obvious for video coding [2]. Instead of scalar quantization, vector quantization is also introduced to image coding [3]. To judge the performance of coded image quality, an objective quality measurement is also an important topic. Peak signal-to-noise ratio (PSNR) is a common measure of video quality. Structure similarity index (SSIM) is an image quality measure which has been shown to be more consistent with human perception for medium quality contents [4].

Some image and video coding standards will be discussed in the following sections.

2.2. Design examples of image coding standard

In this chapter, I will introduce the still image coding method which is popular in current image processing standard, like JPEG and JPEG 2000. The main coding

algorithm is presented in section 2.2.1. In section 2.2.2, I will briefly describe H.264 which has higher coding efficiency in video compression technology. And the video processing flowchart is also detailed in this section.

2.2.1. JPEG image coder

For the past few years, a joint ISO/CCITT committee known as JPEG (Joint Photographic Experts Group) has been working to establish the first international compression standard for continuous-tone still images. JPEG features a DCT-based lossy compression and it is sufficient for a large number of applications. In **Fig. 1**, we could clearly see that coder includes three main parts: transform, quantization, and entropy coding. The image is processed block by block.

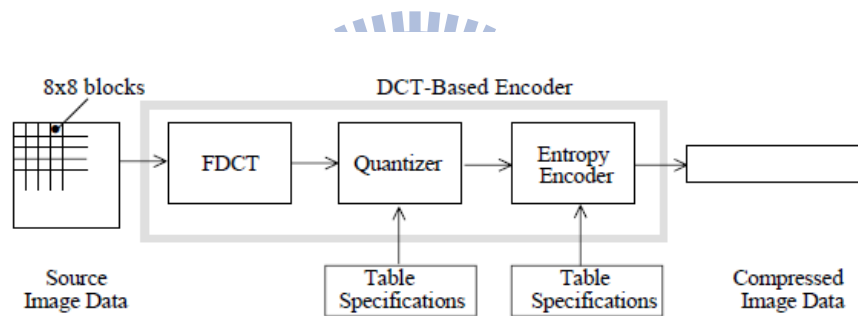

Fig. 1 DCT-based encoder processing steps

JPEG also supports lossless compression using prediction method, which is called JPEG-LS, and this encoder structure is shown in the **Fig. 2**. JPEG-LS is a late addition to the JPEG standard. Encoder can access the left, upper-left, upper blocks as references to predict the current block. Lossless codec typically produce around 2:1 compression for color images with moderately complex scenes [5]. More information can be referenced in [6].

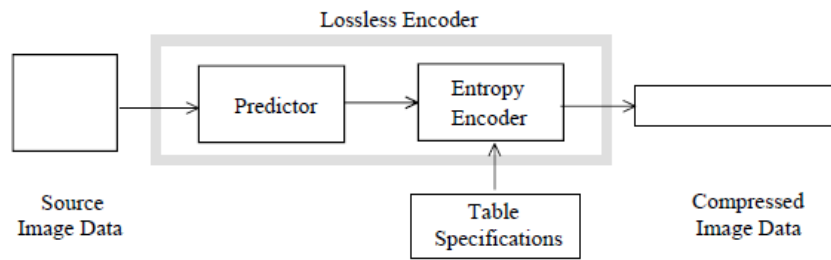

Fig. 2 lossless mode encoder processing steps

While JPEG2000 provides an advantage in compression efficiency over JPEG, its primary advantage lies in its rich feature set. Central to this standard is the scalability that allowing image components can be accessed at different resolution and spatial region of interest [7]. Two primary reasons for JPEG2000’s superior performance are the wavelet transform and embedded block coding with optimal truncation (EBCOT) [8].

2.2.2. H.264 intra coder

The major video coding standard like MPEG-2, MPEG-4 Visual, and H.264 incorporates motion estimation (ME) and compensation (MC), a transform stage and entropy coding. The model is often described as hybrid DPCM/DCT codec [9][10]. H.264 is the most high performance video codec in today, **Fig. 3** shows H.264 encoder flowchart. The encoder includes two dataflow paths, ‘forward’ path is from left to right and ‘backward’ path is from right to left. Because encoder side needs the reconstructed image to predict next frame, backward path is the reconstruction path which simulates the decoder operation.

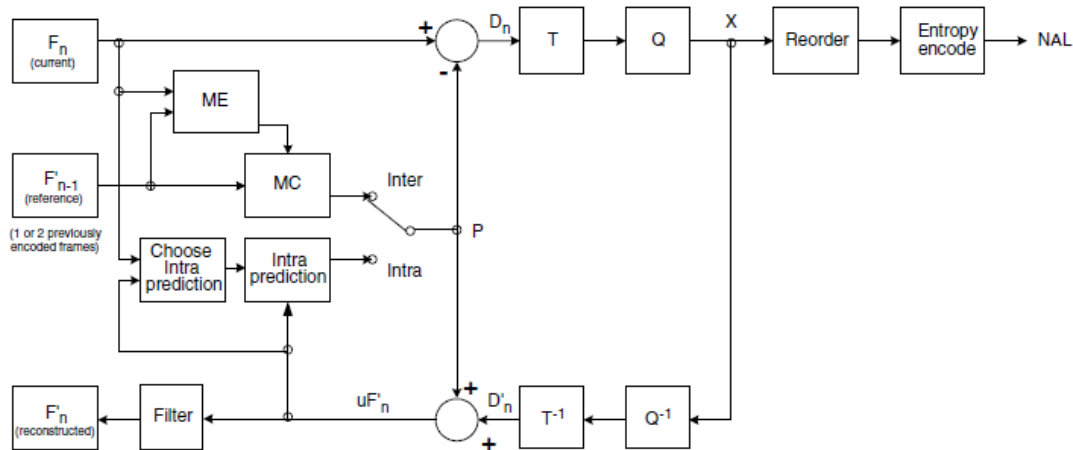

Fig. 3 H.264 encoder

H.264 also processes the images in blocks and can divide the image into more small blocks compared to JPEG. H.264 contains three prediction modes: intra prediction, inter prediction and bi-directional prediction [11]. Intra prediction exploits spatial correlation within one picture. In intra prediction (I-frame), the neighboring reconstructed macroblocks in current frame are used to predict the current macroblock. If the I-frame is also an IDR-frame, the latter inter-frames cannot access the previous frame before IDR-frame as reference frame. This IDR-frame is designed for random access in the video. For inter prediction (P-frame), previous reconstructed images are used to predict the current frame. This part involves motion estimation and motion compensation, and encoder can select the best reference frame joint rate and distortion optimization. Macroblocks in inter-frame also can be coded in intra blocks. When there is a scene change, many macroblocks will be coded in intra blocks. And H.264 also provides bi-directional prediction (B-frame), encoder can reference more reconstructed frames to improve the prediction accuracy.

After prediction using different modes, the prediction error, residual frame, is transformed to another domain for removing the correlation. H.264 uses integer discrete cosine transform (DCT) for reducing the multiplication operation which can speed up the computation and decrease cost of application product. Transform

coefficients include two parts, AC coefficient and DC coefficient. DC is the measure of average value of image samples. There is strong correlation between DC coefficients of blocks so Hadamard transform is further used to compact the data energy again. Current two-dimension transform includes two sizes, 4x4 and 8x8. After the transformation, data is quantized according to different quantization step size. H.264 also supports rate-control which can adjust the quantization step dynamically at frame level and macroblock level to approximate the required bitrate.

The entropy coding in H.264 contains two methods, context adaptive variable length coding (CAVLC) and context-based adaptive binary arithmetic coding (CABAC) [12]. Huffman coding needs to calculate the probability of each symbol and assign the integer bits for each symbol. But there are two disadvantages, we need to transmit the probability tables and it also cause time delay. So CAVLC uses the fixed code-table which is trained by various video materials to encode the symbol and the previous information is referenced in the encoding process. On the other hand, arithmetic coding transmits the whole symbols as a codeword, so it can be more close to the optimal bitrate compare to Huffman coding. It's obvious that using integer number of bits for each symbol is unlikely to come so close to the optimal number of bits. Therefore the arithmetic coding can outperform the Huffman coding. H.264 also contains many context probability models to model the feature of data and the probability model is converged in the encoding process. This design improves the coding efficiency and cause CABAC to outperform CAVLC.

Compare to JPEG and JPEG2000, still image coding in H.264 has higher coding efficiency because it involved the enhanced intra prediction algorithm and the deblocking filter. In [13][14], they investigate the performance of H.264 intra coder and compare the quality of image, and the complexity with the commonly used image coder, JPEG and JPEG2000. Both papers conclude that H.264 intra coding average

has better performance than JPEG and JPEG2000. H.264 intra coding and JPEG2000 has similar performance at low bitrate condition, such as 1 bit per pixel. H.264 has 4 different prediction directions for 16x16 MBs and 9 different prediction directions for 4x4 blocks [15] shown in **Fig. 4** and **Fig. 5**. Few approaches are proposed to reduce the complexity of intra coding. In [16], they limit the intra prediction modes using the directional information at the 16x16 prediction mode. In [17], early termination is decided by the computation of cost function and selective computation of highly probable modes. And the paper [18] presents a three steps algorithm for H.264 4x4 intra prediction.

H.264 spends little bits at prediction so the prediction quality is worse at the complex areas. There are also some papers proposed to improve intra-frame quality. In [19], they consider the distinct image singularities within the model of piece-wise smooth functions, etc edge. In [20], template matching is introduced to the subset of current predictor set. It's useful when the image contains repeated patterns but it suffers the problem of parallel encoding. Line-based and resample-based intra prediction is also proposed in [21]. Resample-based intra coding is suitable for the high definition videos. However, intra prediction quality is still worse on complex contents and it doesn't remove the coherence between signals. That results in high residual bitrate at entropy coding stage. If we can find the trade-off between prediction header cost and residual bitrate, the overall codec performance will be improved.

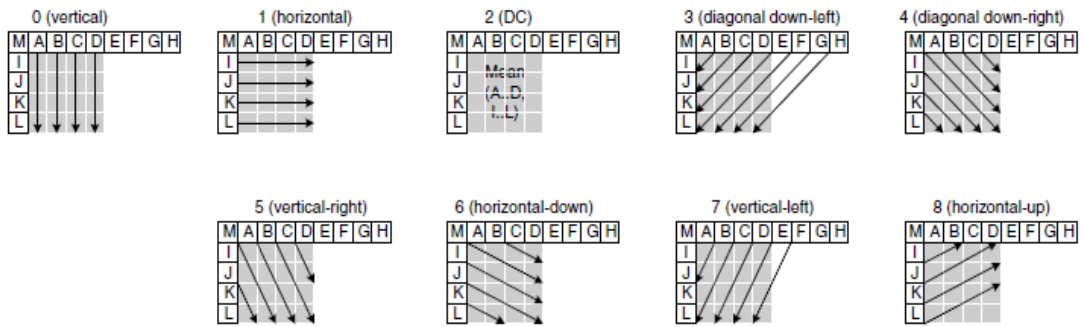

Fig. 4 4x4 intra block prediction modes

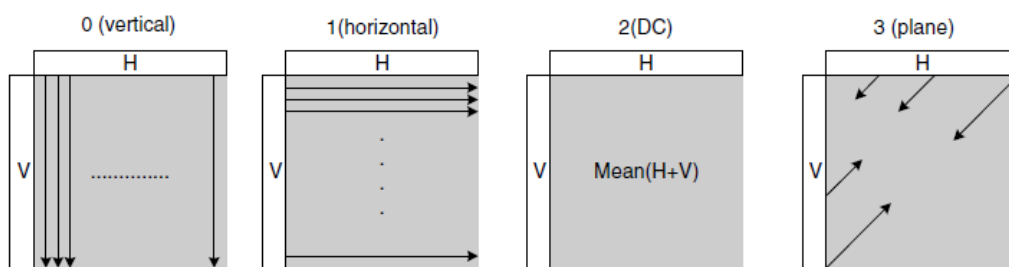

Fig. 5 16x16 intra block prediction modes

2.3. Signal predictions in speech codecs

For complex images, H.264 block-based intra prediction cannot produce good predictor. Its method is suitable for smooth area but not for highly textured area, like grass and waves in the image. One way to handle prediction of complex signals with repeated patterns is to use the coding method similar to speech coding to capture the edge information and the texture information of the image [22]. We can describe the texture of the image using a way similar to speech codec to depict the formant of the voice without the constraint of the block shape. Images can be converted to one-dimension information and then processed in one dimension domain.

Speech codec process the signals using linear prediction filter first, and then prediction error called excitation is down-sampled by closed-loop or open-loop method. The number of reserved excitation represents the bitrate directly. Excitation selection can be regular or produced by impulse generator. In the early days,

RPE-LTP based codec not only reserved the excitations by open-loop method but also apply long-term prediction to catch the peak period of the voice [23]. In the previous experiments, it is shown that we only need to reserve 1/3 excitations and can simulate the speech well enough. Some speech codec also use excitation code-book to select the proper excitations, and reduce the bits allocation for recording excitation with the transmission of the code-book index. CELP-based method is one of the cases. **Fig. 6** is the simple diagram of the LPC decoder. From the figure we can clearly see that impulse train generator is for simulating the pitch period, and gain computation is mainly related to the energy level of the signal, and synthesis filter specify the synthesis coefficients for reconstructing signals.

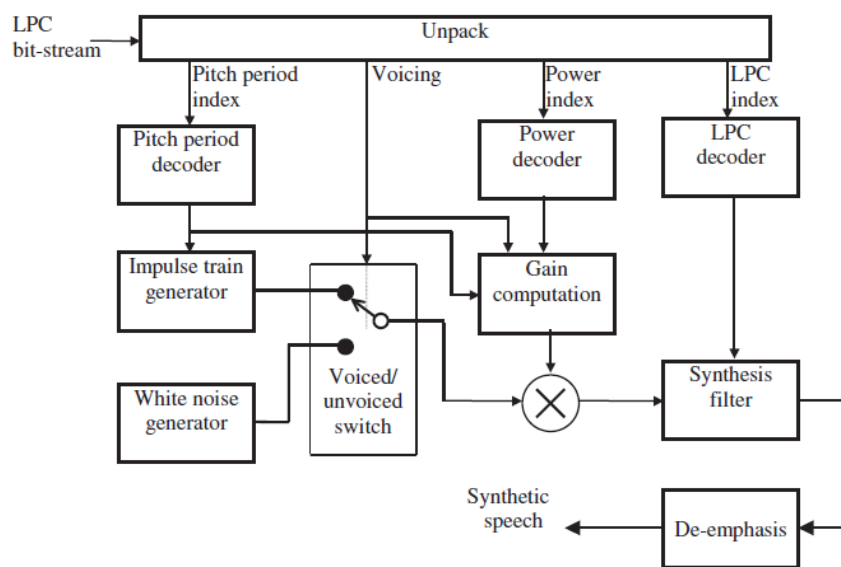

Fig. 6 LPC-based speech decoder

Fig. 7 shows the block diagram of a generic CELP encoder. The perceptual weighting filter in the diagram is for adjusting the prediction errors because human is sensitive to specific frequency band. So prediction error in different frequency band may have different weighting. Excitation code-book is trained by the input signals, and this design is also a “close-loop” CELP encoder because it involves the error minimization in spatial domain.

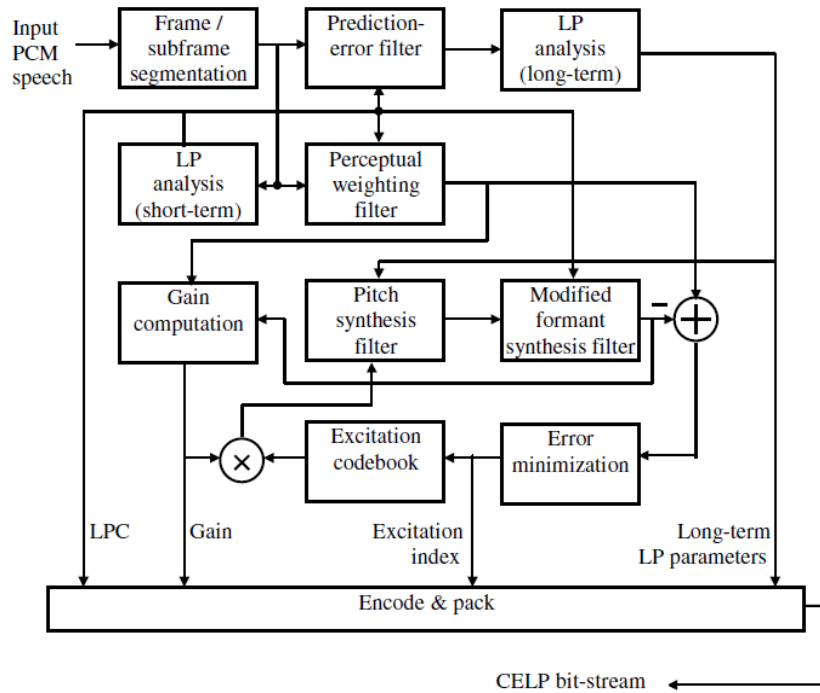
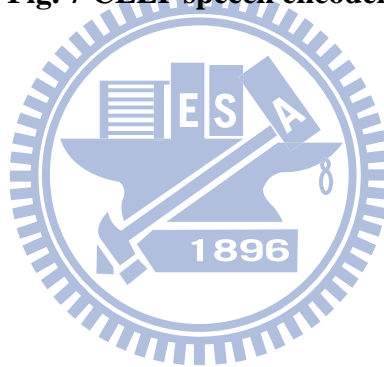

Fig. 7 CELP speech encoder



Chapter 3. Proposed Intra Coding Method

Because we want to remove the artifacts of block-based prediction and predict the repeated complex pattern more correctly, we try to predict the signals in one-dimensional domain with more flexible algorithms. Two-dimensional image blocks will be scanned into one dimension data using Hilbert's scanning order [24]. For the investigation in this thesis, 16×16 macroblock size is scanned into 1-D signals using pre-computed Hilbert scan path. After expanding the 2-D image to 1-D 256 signals, different prediction methods will be applied according to the feature of the signals. The signals are classified in two categories: smooth signal and textured signal. Fixed segment length is proposed in current coding structure and each segment contains 16 samples. It can be observed that each pixel has close relation with neighboring pixels so the Hilbert scan path is able to convert a 2-D signal to 1-D while maintain the spatial similarity within image pixels. A brief summary of the proposed intra-coding mechanism is described as follows.

For textured segment, we model the prediction error as random noise. First step, Signal is analyzed by order one linear prediction filter after segmentation. And then prediction error is down-sampled using closed-loop (analysis-by-synthesis) method. The excitations are down-sampled irregularly with minimal spatial errors. For this purpose, the synthesizer is also included at the encoder side to minimize prediction errors in spatial domain. Original magnitude of the excitation is modified at the synthesizer for better prediction. Instead of uniform scalar quantization, vector quantization is used at the predictor description for textured segment to decrease the header bitrate. Arithmetic entropy coding is also applied to the predictor syntax. Some context model is also designed for different header syntax to approximate optimal

bitrate. For smooth segment, we simply compute the mean of the samples and apply uniform scalar quantization for prediction. The details of each step of the proposed algorithm are presented in the following sections.

3.1. Intra Prediction Block Diagram

Fig. 8 shows the proposed intra prediction framework and the syntax of predictor description. The mode decision module segment the input signal unit into smooth unit or textured unit. For textured unit, the predictive coder is composed of three main parts: LP filter, excitation sampling, and quantization. After the predictive coder, the predictor parameters are quantized and entropy coded.

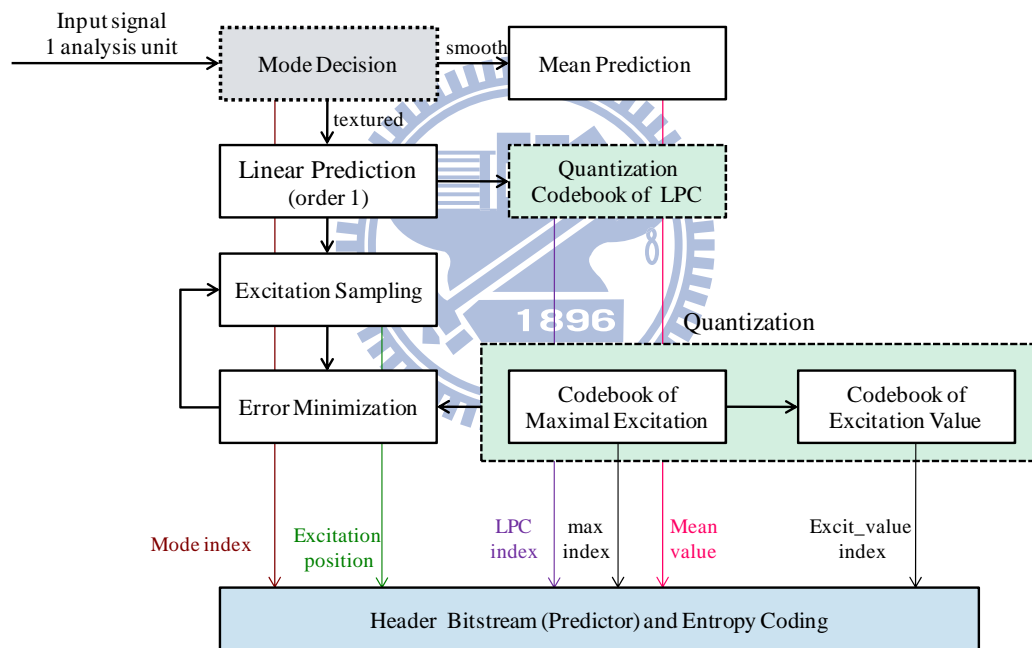

Fig. 8 proposed intra prediction structure

3.2. Preprocessing

3.2.1. Hilbert scanning

The Hilbert curve is a space filling curve that visits every point in a square grid and it was described by David Hilbert in 1982. Hilbert curve has been widely used in image processing because the coherence in neighboring pixels is very important. It is also widely believed that Hilbert-space filling curve can achieve best clustering

[24][25][26]. We can produce Hilbert curve in different resolution recursively and apply to $2^n \times 2^n$ image. 2-D image is scanned into 1-D signals using Hilbert's method, as shown in **Fig. 9**. Curve starts from left-bottom corner and ends at right-bottom corner. Hilbert's method reserves the signal similarity so this pattern is used to process the signals in one dimension. Because we may integrate our intra prediction method with current prediction methods in H.264, 16x16 block size is proper for scanning. This helps the further integration by intra mode decision at macroblock level. And each macroblock in the frame is preprocessed like the **Fig. 10** from upper-left to bottom-right. 1-D signal is further processed according to their feature.

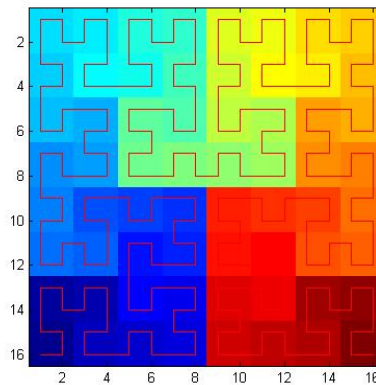

Fig. 9 Hilbert curve

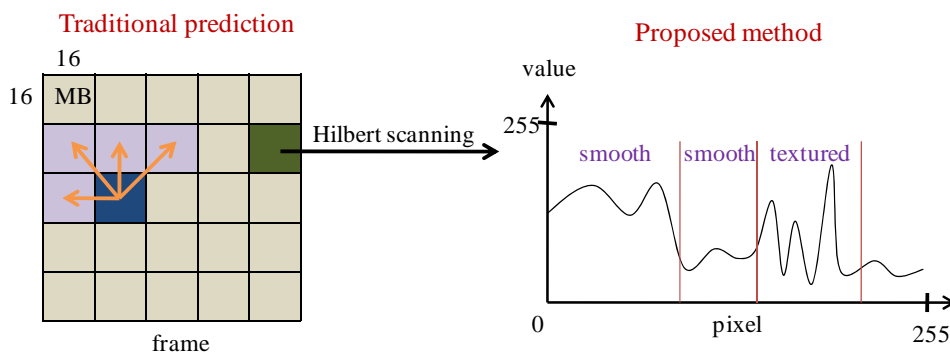

Fig. 10 scan 2-D image to 1-D signal

3.2.2. Segmentation

Signal is classified by three factors: variance, average value, and the intensity

difference between neighboring pixels before we apply different algorithms to encode the signals. Signals have same features will be merged and the length of segment is adaptive. **Fig. 11** is the example of segmentation, and the segment 1 is processed as smooth segment, and the segment 2 is processed as textured segment. From the experiments of 4 cif sequences, **Table 2**, there are average 64% segments which length is equal to one analysis unit (16 samples). On the other hand, more bits is allocated for recording segment length, so fixed segment length (1 analysis unit) is used at current design structure.

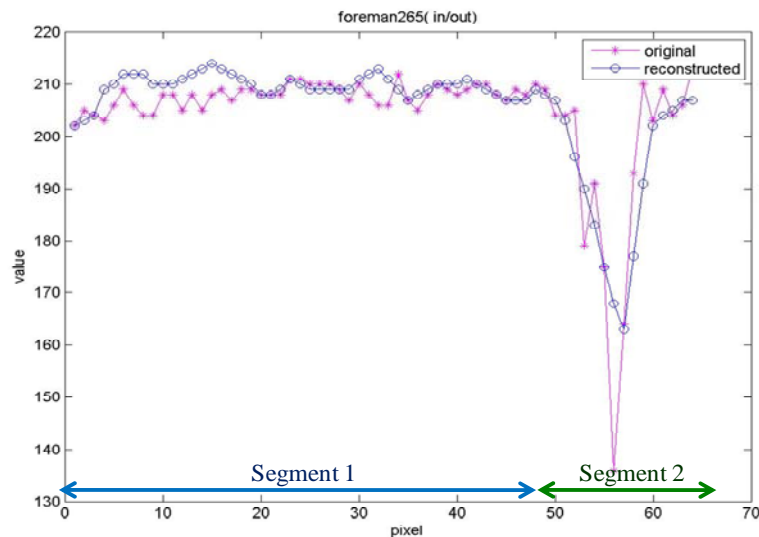

Fig. 11 segmentation example

Video \ Length	Length = 1	Length < 8	Length = 64
flower.cif	69%	91%	2%
mobile.cif	59%	93%	0%
Stefan.cif	54%	89%	0%
foreman.cif	77%	100%	0%

length (analysis unit)

Table 2 segment length

3.2.3. Increase bit depth of signal

To get higher prediction accuracy, the signals bit depth is extended from 8 bits to 11 bits. This way can decrease the rounding effect in the encoding process. And the

post processing function is also needed to rescale the signal.

3.3. Mode decision

After scanning the 2-D signal into 1-D signal, different prediction method is used according to the feature of the signals. The variance of the signal is the mainly measurement for its characteristic. In my proposed method, segment length is fixed in 16 samples at current stage. So we don't need to spend more bits of recording the segment length. Segment mode is decided by the fixed threshold. If the signal is smooth, I use simple mean value of the segment to predict. Otherwise, if the segment has variance larger than the threshold, more flexible algorithm is applied to achieve better prediction quality. Fixed segment length could decrease the bits for segment length description but neighboring segment may have similar feature. We may need to combine the segments which have same feature in the future. Two prediction modes are supported in current intra prediction structure and spend one bit of storage.

3.4. Linear prediction (Analyzer)

If the segment is textured, we used more complex prediction algorithm. First, I assume the signal $x[n]$ is regressed on previous values of itself, plus an error term $v[n]$. And the a_1, a_2, \dots, a_M are known as the autoregressive (AR) parameters and the $v[n]$ represents a white noise process if the prediction order is higher enough.

$$x[n] = -a_1x[n-1] - a_2x[n-2] - \dots - a_Mx[n-M] + v[n]$$

$$x[n] + a_1x[n-1] + \dots + a_Mx[n-M] = v[n]$$

$H_A(z)$ denotes the system function of the AR analyzer and the direct form realization is shown in the **Fig. 12**. This filter takes $x[n]$ as its input and $v[n]$ as its output. This all-zero filter (FIR) transforms an AR process at its input and white noise at its output.

$$H_A(z) = \frac{V(z)}{X(z)} = \sum_{i=0}^M a_i z^{-i}$$

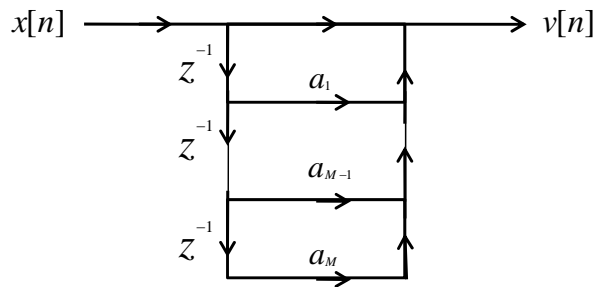

Fig. 12 direct form realization of analyzer

From the experiment result, order 3 filter can achieve good prediction quality. When prediction order is higher than 3, it's nearly useless. The relation between luma residual bitrate and the order of LP filter is shown in **Fig. 13**. It is obvious that LPC order converges at 3 coefficients because textured segment has lower correlation between neighboring signals. But in the actual implementation, the bits allocation of LP coefficients and the resulting residual bitrate are both considered. I select order 1 filter in my proposed prediction structure.

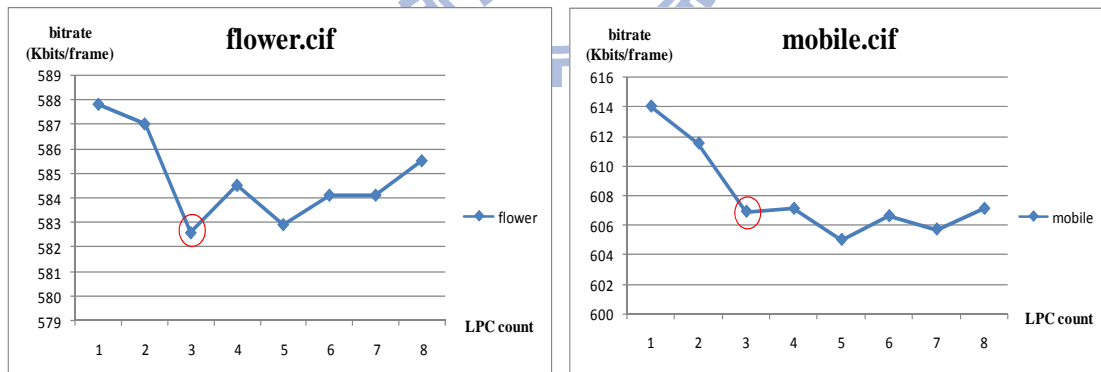

Fig. 13 comparison between luma residual bitrate and LPC order

3.5. Synthesizer

Decoder includes the synthesizer to reconstruct the signals. Encoder side also needs the synthesizer for optimal excitation down-sampling. Various excitation positions are selected and reconstructed excitations are the input of the synthesizer at

encoder side. So encoder can simulate the operation of decoder side, and find the best position of excitation by minimizing the spatial domain errors. Because encoder selects the excitation through synthesizer, this method is called “analysis by synthesis” or “close-loop” method. On the other hand, excitation also would be quantized for transmission, so we can more accurate simulate the decoder’s operation by including the quantization process in close-loop method. And the optimal excitation value is found by the synthesizer by reconstructing the original signal value. Although this design would be more complex and time consuming compared to open-loop method which doesn’t include synthesizer at encoder, we can increase the prediction precision and hence decrease the residual bitrate in latter part.

Synthesizer is an IIR filter to synthesize the signals by filtering white noise using all-pole filter. Synthesizer filter and the direct form realization are illustrated in **Fig. 14**. There is an order 1 synthesizer corresponding to the order 1 analyzer at encoder side.

$$H_S(z) = \frac{X(z)}{V(z)} = \frac{1}{H_A(z)} = \frac{1}{\sum_{i=0}^M a_i z^{-i}}$$

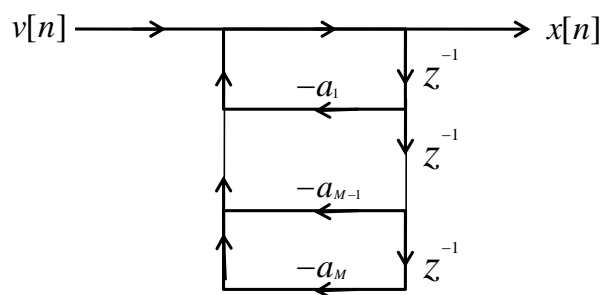

Fig. 14 direct form realization of synthesizer

3.6. Excitation sampling

After signal is processed by LP filter, excitation should be down-sampled for storage and transmission. The textured segment is more difficult to predict so has higher excitation amplitude, we should reserve more excitations to catch the valley or

peak which may be the edge or texture in the image. 5 excitations are reserved in each segment (nearly down-sample 3). And the position of excitation is selected by minimization the difference of original signal value and the reconstructed value. This part includes the synthesizer for reconstructing the original signals and quantization error is also in consideration.

Example in **Fig. 15** shows the residual distribution in frequency domain, and it's clearly that RPE-based method has lower residual energy compared to H.264 intra coding. Using fixed grid excitation selection and open-loop method to find the fine excitation positions is simple but not optimal. Open-loop method only considers the total error magnitude after the excitation selection. It doesn't reconstruct the signals and compare the prediction error in spatial domain. Thus I use closed-loop method to choose the excitation optimally and adjust the excitation amplitude when synthesizing the signals. Adjust the original value of excitation can construct more accurate reconstructed value by the synthesizer at decoder side. Optimal excitation amplitude can be reconstructed through synthesizing at encoder. The simple system diagram of closed-loop method is shown in **Fig. 16**. In **Fig. 17**, the residual distribution is shown before and after we modified the excitation value properly. It reveals that the error distribution using our proposed method is scattered in frequency domain and the residual energy is much lower. After excitation sampling in the below diagram, quantization process is applied to excitations in my implementation. Thus the synthesis filter can get the same information as decoder side.

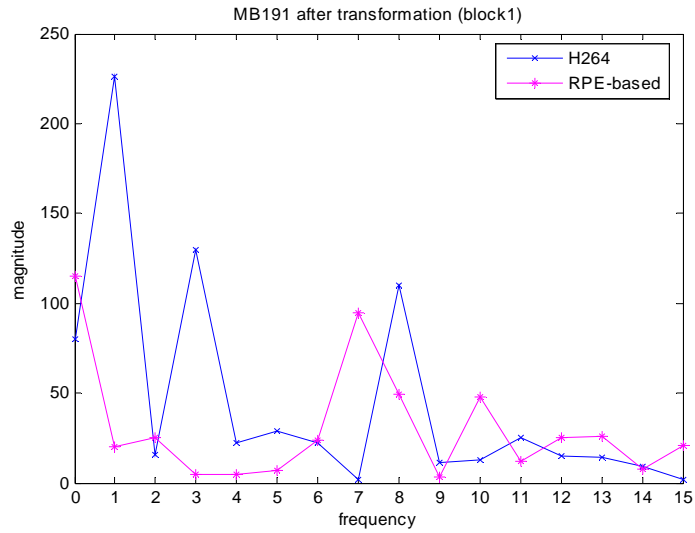

Fig. 15 residual distribution of H.264 intra coding and RPE-based method

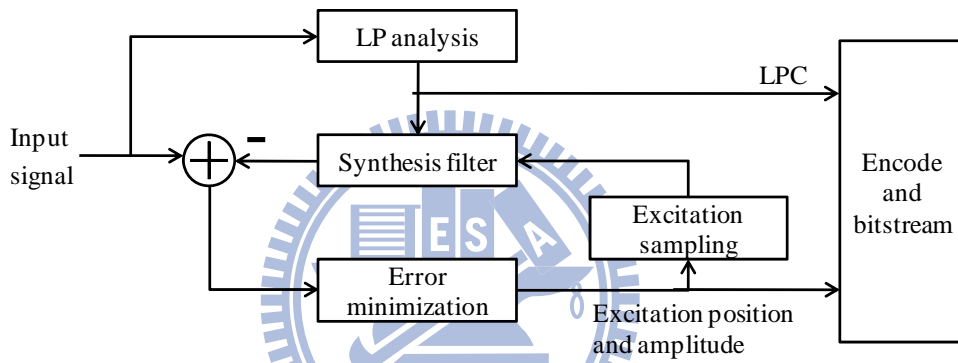

Fig. 16 closed-loop encoder (analysis by synthesis)

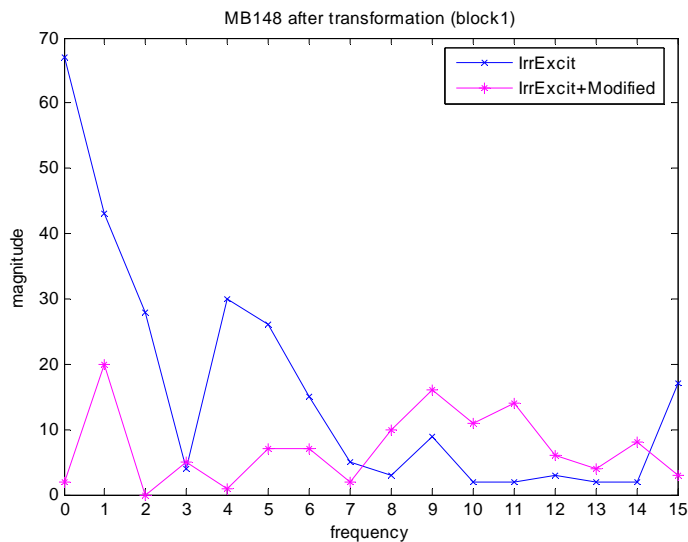

Fig. 17 residual distribution of irregular excitation selection and modified the excitation value properly

3.7. Quantization

The description syntax of the predictor is also quantized to reduce the header bitrate. This part contains the quantization of linear prediction coefficient and excitation value for textured segment. In smooth segment, we only use uniform scalar quantization on the average value of the signals.

For the textured segment, excitation is further divided to two parts: magnitude of maximal excitation and the ratio of excitation value relative to maximal excitation value. It means each segment contains one maximal excitation magnitude and 5's relative ratios. It is well known that vector quantization has better performance than scalar quantization. So instead of scalar quantization, vector quantization is used in coding the excitation ratios and the vector code-book is trained by different video materials. Code-book is fixed in the codec so we don't need to transmit it. And Code-book size will be discussed in following sections.

3.7.1. Linear prediction coefficient

Linear prediction coefficient is converted to reflection coefficient (RFC) first. Because using the reflection coefficients allows a straightforward supervision of stability status, since the condition $RFC \leq 1$ can easily be monitored. RFCs also can be found from the lattice filter structure, in **Fig. 18** [22]. Four different video materials and 1/3 frames of the videos are selected for training the vector quantization code-book of RFC. Smooth video like foreman.cif and the more complex video like flower.cif are included. Due to the trade-off between header bitrate allocation and residual bitrate, the proper size of the RFC code-book is 8.

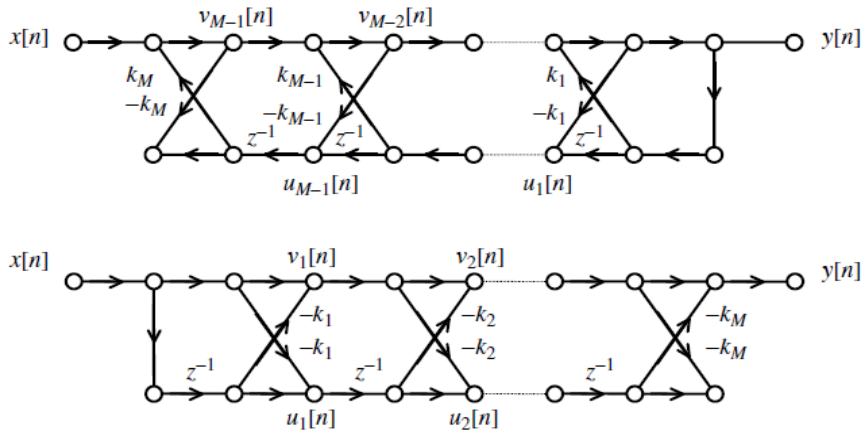

Fig. 18 implementation of lattice structure of all-pole filter (top) and all-zero filter (bottom)

3.7.2. Maximal excitation

After we down-sampled the excitations using close-loop method, maximal excitation is sampled in these excitations and a quantization code-book is trained for its magnitude. From the experiment result, proper code-book size is 32 and it's sufficient to represent the amplitude. To signal the 5 excitations values, I only need to record the amplitude ratio relative to the value of maximal excitation. This is called adaptive quantization (ADPCM). This design can encode the excitation amplitude in more flexible way.

3.7.3. Excitation value

As discussed previously, the amplitude of the reserved excitations is recorded as the ratio relative to the value of maximal excitation. For this part, I apply vector quantization instead of scalar quantization to approximate the optimal bitrate. The code-book size may be limited by available memory, so the proper code-book size is 256x5 by experiments. Each segment has 5 ratios and code-book contains 256 vectors.

For simulating the operation at decoder side, encoder side will run 256 times to find the best quantization vector and the quantization error is computed at the

synthesizer. Although it has higher time and computation complexity at the encoder side due to optimal quantization code-book selection but it still not affect the complexity of decoder side and improve the prediction accuracy.

3.8. Predictor entropy coding

The description of the predictor should be further coded for transmission and storage. Arithmetic coding is used for entropy coding. Like the CABAC in H.264, a context model is constructed for encoding segment mode assuming the neighboring segments may have similar feature. And 16 context models are designed to encode the position of excitations. For the other predictor syntax elements, I simply use equal probability to encode the symbols. H.264 uses probability table to update the context probability and prevents the multiplication operations. Because my proposal is integrated into JM16.1 directly, transition rule and transition table of probability in JM16.1 is reused for my intra predictor.

3.8.1. Segmentation mode

Each segment cost one bit for recording segmentation mode, smooth or textured. Because the neighboring segments may have similar feature, I design a context model for syntax probability distribution. And from the experiments, this can save nearly 30% bits.

3.8.2. Excitation position

There are 16 samples in a segment and 5 positions of reserved excitations are recorded. If we encode the position directly, we will spend 20 bits of each segment. So some context models are designed for recording the position of excitation in a way similar to the encoding of significant map in H.264. In the binarization process, every position has a corresponding context model. If excitation is reserved in this position, assign “1”. Otherwise, assign “0”. And then these binary input symbols are encoded

using arithmetic coding. And from the experiment result, it shows that this method can save nearly 30% bits. Binarization rule is illustrated in **Fig. 19**, and the symbol is coded from first position to the last position. Because we already know the excitation count is 5, we don't need to encode the last excitation (marked X in the figure) in this example.

Excitation value	0	20	0	0	0	0	30	0	-6	0	0	0	0	17	2	0
Binary map	0	1	0	0	0	0	1	0	1	0	0	0	0	1	1	X

Fig. 19 binarization of excitation position

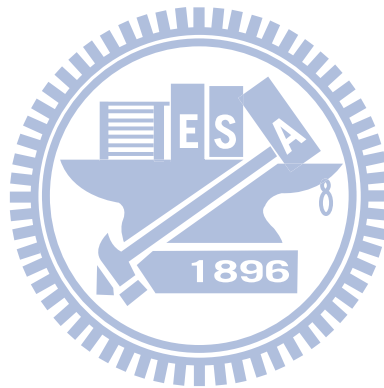

Chapter 4. Proposed Residual Coding

The residual in each image block is transformed, quantized, and entropy coded into the compressed bitstream. In this chapter, we discuss the details on transform coding and entropy coding.

4.1. Transform coding

Because the proposed intra prediction method processing signals in one-dimension domain, the original 2-DCT in H.264 should be removed and redesign a suitable 1-D transform. On the other hand, the quantization process in H.264 is integrated with transformation for decreasing rounding errors and H.264 also support adaptive quantization which models the distribution of quantization error, so the quantization process is also redesigned for my proposed method. We will discuss these processes from this section.

Spatial domain information can be transformed to another domain and data in transform domain should be de-correlated and compact. I apply 1-D integer cosine transform (ICT) on residual information using the theory of dyadic symmetry [27].

Definition of dyadic symmetry: A vector of 2^m elements $[a_0, a_1, \dots, a_{2^m-1}]$ is said to have the i th dyadic symmetry if and only if $a_j = s \cdot a_{j \oplus i}$, where \oplus is the “exclusive or” operation, $j \in [0, 2^m - 1]$, and $i \in [1, 2^m - 1]$. $s = 1$ when the symmetry is even and $s = -1$ when symmetry is odd. Detail theory of dyadic symmetry can be referenced at [28][29]. We can use this property to convert DCT to ICT.

To eliminate the floating point arithmetic so the real magnitudes of the DCT component is approximated by 8-bit integers. The paper [27] shows how to convert the order-8 cosine transform into a family of integer cosine transform. And an

order- $2n$ $T_{2n}(i, j)$ orthogonal transform can be generated from an order- n $T_n(i, j)$ transform as follows:

(a) The first n basis vector of $T_{2n}(i, j)$:

$$T_{2n}(i, j) = T_n(i, j)$$

$$\text{And } T_{2n}(i, 2j + 1) = T_n(i, j) \text{ for } j \in [0, n - 1]$$

(b) The last n basis vectors of $T_{2n}(i, j)$:

$$(i) \quad T_{2n}(i + n, 2j) = T_n(i, j)$$

$$\text{And } T_{2n}(i + n, 2j + 1) = -T_n(i, j) \text{ for } j \in [0, 2, 4, \dots, n - 2]$$

$$(ii) \quad T_{2n}(i + n, 2j) = -T_n(i, j)$$

$$\text{And } T_{2n}(i + n, 2j + 1) = T_n(i, j) \text{ for } j \in [1, 3, 5, \dots, n - 1]$$

The above generation rules are used to compute the order-16 ICT coefficients and then transform matrix is applied to residual frame.

4.2. Entropy coding in H.264

There are two different entropy coding methods in H.264: context adaptive variable-length coding (CAVLC), context adaptive based arithmetic coding (CABAC). In this chapter I will introduce these methods briefly and then discuss the drawback of current design. I also proposed a modification of CABAC which can reduce average 7% bitrate for very high bitrate videos. Proposed modification in CABAC is introduced in the last section.

4.2.1. CAVLC

Before the variable length coding, H.264 uses zigzag scan on the block to get the transform data from low frequency to high frequency. Zigzag scan is shown in the **Fig. 20**. Run-length coding is applied to the scanned information. The number of continues zeros and the magnitude of transform coefficient will affect the residual bitrate. To

catch the distribution of the signals, various VLC tables are selected according to the run-length codes. The transition rule between different VLC tables is also identified in the current H.264 codec. Because most coefficients in high frequency band are zeros, VLC table will assign fewer bits for continuous zeros and small magnitude of high frequency coefficients. The VLC table is trained by various video sequences and its mapping characteristic is for the signal which contains large energy at low frequency band.

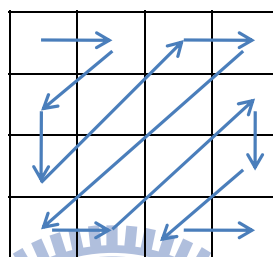

Fig. 20 zigzag scan

4.2.2. CABAC

Arithmetic coding can achieve better coding efficiency compared to variable length coding because it represents the series data in one long floating number and approach the optimal fractional number of bits required to represent each symbol. This prevents the integer bits assignment of each symbol, like Huffman coding. The idea of arithmetic coding is illustrated in the **Fig. 21**. For example, there are two symbols, A and B. We already know the probability of A is 0.3 and probability of B is 0.7. When we read the symbol B, we can use the floating number in $[0.3, 1]$ to represent B. After reading the second symbol B, $[0.51, 1]$ represents “BB”. Finally, the floating number in $[0.51, 0.657]$ represents “BBA”.

H.264 prevents the multiplication operation on floating number, so a 9 bits integer variable is used for representing the floating number in H.264 and H.264 outputs the codeword by shifting the variable.

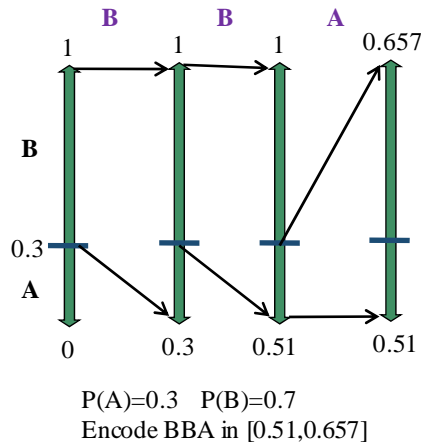

Fig. 21 example of arithmetic coding

H.264 not only designs different context probability models for different syntax but also has many probability models for each syntax element. Each syntax element has its own data distribution, so it should be model by a specific context probability model. First, the context model is initiated for different syntax according to different frame type and quantization scale, and these models will be adjusted by different video contents. H.264 will binarize the symbol first, and then put it to arithmetic entropy coder. By combining an adaptive binary arithmetic coding technique with context modeling, a high degree of adaptation and redundancy reduction is achieved. CABAC coding flowchart is shown in **Fig. 22**[12]. We can better approach the entropy bitrate of the signals by this process. To decrease the complexity of multiplication operation, H.264 use fixed probability transition tables to update the context model. Probability quantization is also involved in the transition table for the limited memory.

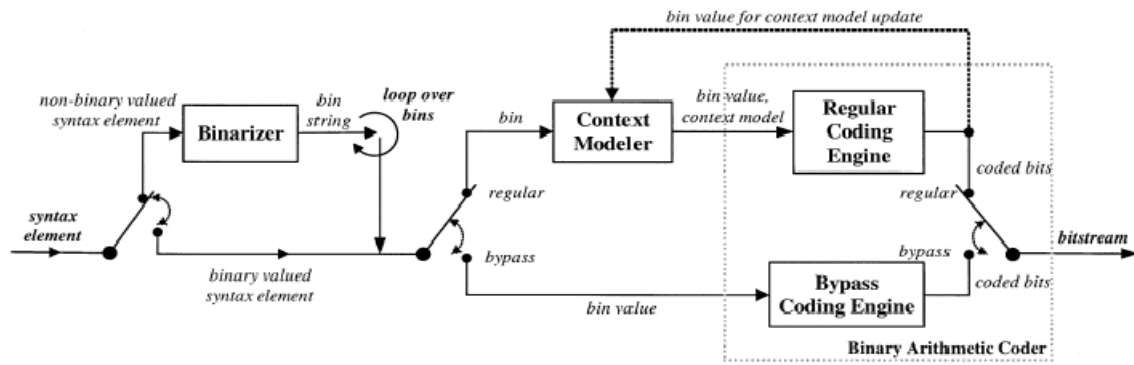

Fig. 22 CABAC encoder block diagram

4.2.3. Issues of CAVLC/CABAC in H.264

Current intra/inter prediction in H.264 is not sufficient so the residual information still contains much similarity. For example, motion estimation is bad if the object has large motion. When the video content is too complex, intra block is needed in inter frame. Moreover, more blocks will be coded in PCM mode. In the transform domain, most blocks energy is compacted to low frequency band. Current entropy coding structure of CAVLC/CABAC is still designed for the data which contains much energy at low frequency band and lower energy at high frequency band. If the block contains higher energy in high frequency band or the energy is scattering, we may spend more bits in entropy coding because the current model is not suitable for these features.

Run-length coding in CALVC scans the number of continues zeros and the magnitude of non-zero coefficient. Run-length code is encoded from low frequency to high frequency band. Transition between different VLC tables is decided by the threshold which is fixed in each VLC table. Current threshold of the high frequency band is smaller compared to the other bands. If residual data have larger amplitude at this band, VLC table will assign many bits to encode the coefficient. This would be a drawback of current CAVLAC model. In [30], they redesign a VLC-table for lossless video coding. And this paper shows that it can provide approximately 10% bitrate

saving compared to the original CAVLC scheme in H.264.

CABAC has divided the transformed coefficient coding into two parts, significant map and significant coefficient. Significant map is for recoding the position of non-zero coefficients and significant coefficient is for the coding of non-zero coefficient value. CABAC also further split the significant coefficient into two parts, absolute part and one part. Value one is coded first and the remaining magnitude is further coded at absolute part. Most entropy bitrate comes from the magnitude of transformed coefficients. CABAC in H.264 designs 5 context models to capture the data distribution and the transition between different context models depending on the magnitude of the coefficients. If energy is scattering, this design is not suitable. On the other hand, significant map will allocate more bits when energy is scattering because context model cannot predict the position of non-zero coefficient. Although CABAC has 16 context models for significant map, it's still not proper when energy is scattering or under large quantization scale condition.

4.3. Proposed modification in CABAC

CABAC has higher bitrate than CAVLC where their reconstructed video quality is almost same under high bitrate condition. Five HD video sequences are tested and the result is shown in **Table 3**. From the experiments, I found that there is a problem in the encoding of significant coefficient. CABAC encoding the magnitude of coefficient uses fixed threshold (value is 13) to divide the magnitude to two parts. If coefficient magnitude is smaller or equal to this threshold, CABAC will encode the magnitude use many context probability models. And the probability model will be updated through encoding process. Otherwise, CABAC encode the magnitude with equal probability model.

video method	flower (48dB)	mobile (47.6dB)	stefan (51dB)	city (50.8dB)	funfair (50.7dB)
CAVLC	14587	14560	13128	11877	14497
CABAC	15780	14893	13725	11800	14402

Kbit/s

Table 3 bitrate comparison of CAVLC and CABAC

However, for the lossless or high bitrate videos, coefficient magnate will be large, so the threshold should be smaller. Moreover, this threshold should be adjusted according to different bitrate or quantization scale. To measure the effect of adjusting threshold, the original threshold in CABAC is modified and found that if we could adjust the threshold dynamically in different quantization scale, we can have more bitrate saving under high bitrate or lossless condition. Experiment result using 4 CIF sequences is shown in the **Fig. 23** to **Fig. 25**. It reveals that this adjustment can lead to average 7% bitrate saving for nearly lossless compression.

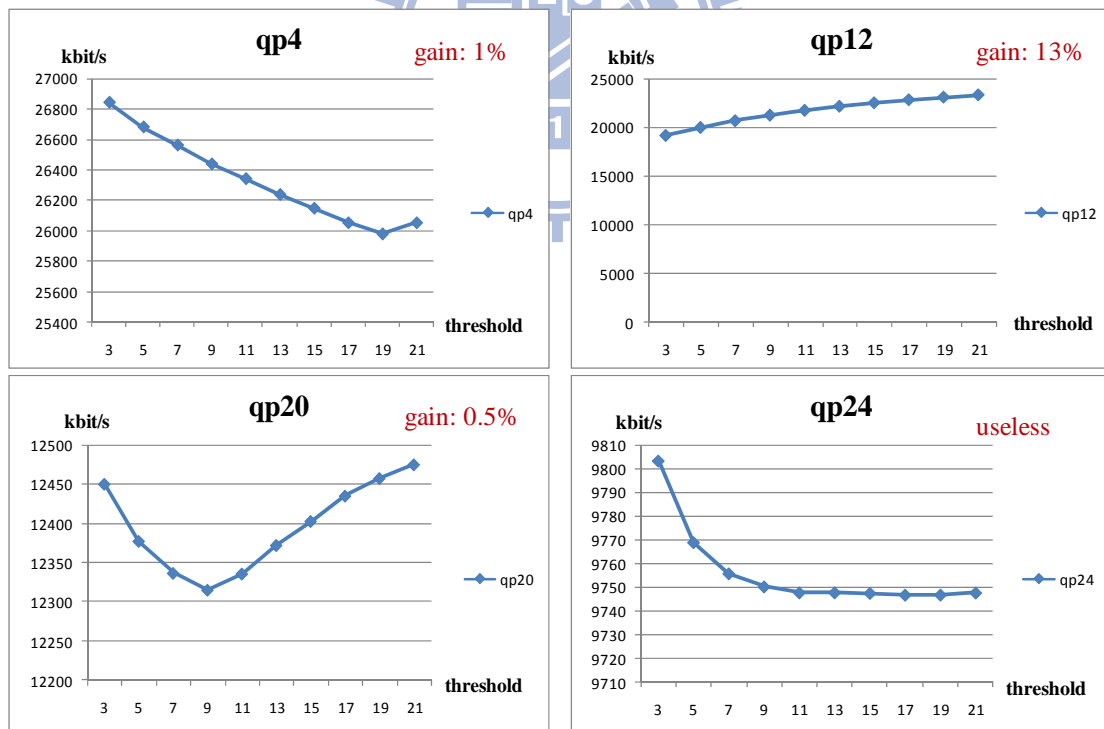

Fig. 23 flower.cif bitrate saving

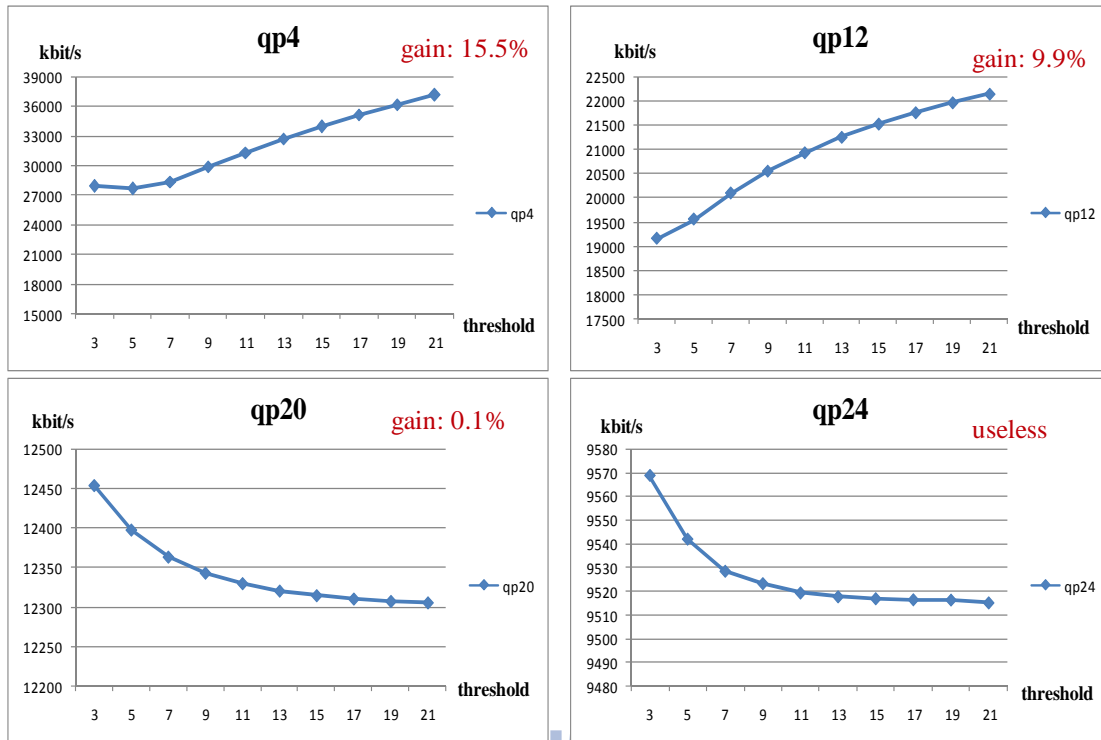

Fig. 24 mobile.cif bitrate saving

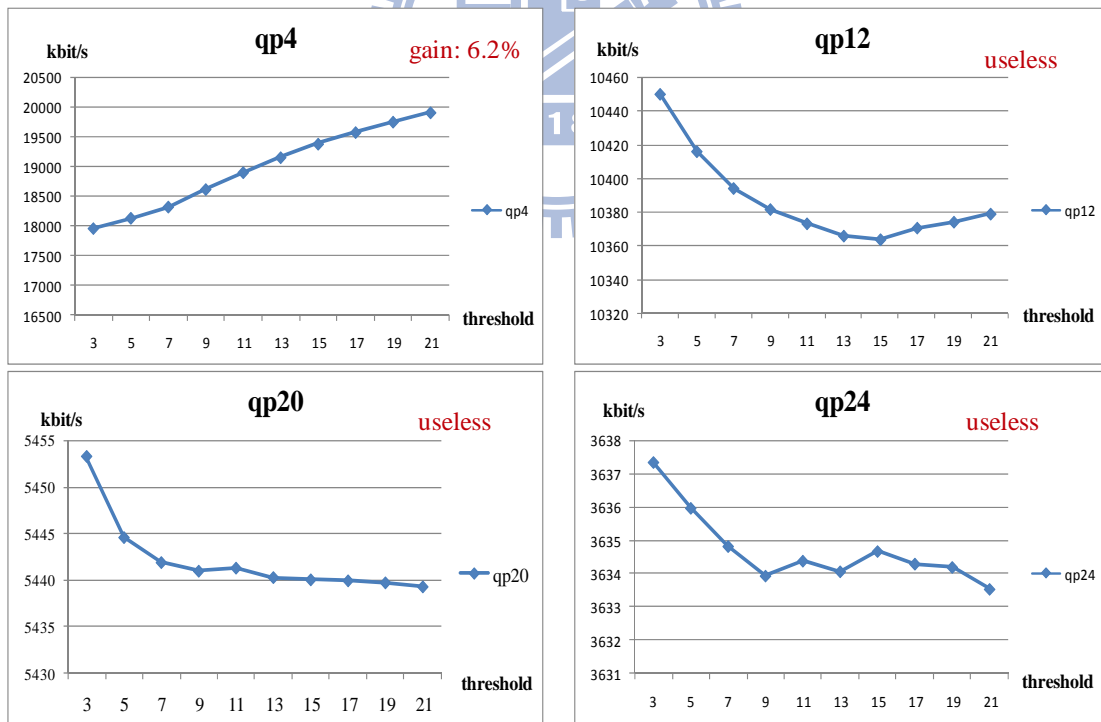

Fig. 25 foreman.cif bitrate saving

Chapter 5. Implementation

The whole proposed prediction structure has integrated into H.264 version JM16.1 using language C. I create a new slice type called MMES_I_SLICE for our proposed intra frame and this parameter can be set in configure file. Main profile is used for the other setting. Because we only consider the luma prediction and compare the experiment result with H.264 in current prediction structure, we bypass the chroma processing and only compare the luma residual bitrate. Our proposed method also can be integrated with original intra prediction methods in H.264 by mode decision at macroblock level. H.264 supports adaptive rounding in quantization process, and this method is based on adjusting the rounding offset to maintain an equal expected value for the input and output of the quantization process [31]. The method provides up to about 1 dB of improvement in coding efficiency performance for high PSNR encoding. So H.264 can have higher reconstruction quality compared to our proposed method. The reconstruction quality using our method is a little worse because I only use simple uniform rounding method now. On the other hand, I don't take rate control into consideration at this stage.

In this chapter I will briefly describe the implementation structure and the main encoding flowchart. And then experiment results will be presented in next chapter.

5.1. Coding structure

The start point of my proposed intra-prediction is at the function: **encode_one_slice**. I also integrate the new intra prediction method into original intra-prediction modes in H.264 using mode decision. Encoder can jointly compare bitrate and the quality of reconstruction image to select the best intra prediction mode

at macroblock level.

I construct two main structures for the implementation: filter state and segment information. “Filter state” includes the lattice filter information which is mentioned in previous chapter. “Segment information” includes the syntax of predictor description, such as segment mode, excitation ratio, and segment bitrate, etc.

Entropy coding functions (CABAC) in H.264 are reused and context probability model is also used for my proposed method. I apply arithmetic coding on the predictor description and the residual information. Many context probability models are also designed to catch the data distribution of the syntax in intra prediction. But for the residual coding, I don’t have large modifications. **Fig. 26** shows the coding flowchart. This picture shows the main encoding function and pipeline in H.264.

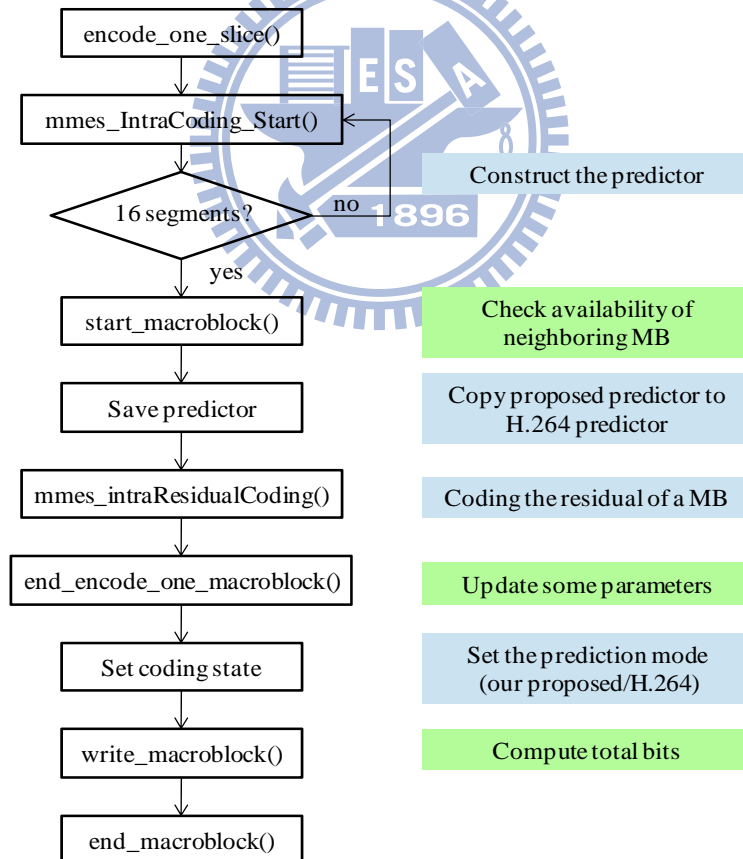

Fig. 26 encoding flowchart

5.2. Prediction bitrate

Current bitrate allocation of predictor descriptions is shown in the **Table 4**.

“Reducible row” means the syntax can be modified or not in the future. “Current bits” row shows the current bits allocation for this syntax. I assign 4 bits for the smooth segment recording the quantized mean value. It’s clearly to see we allocate more bits for textured segment and more complex algorithm is used to improve the predictor quality. Because context model is used for arithmetic entropy coding, bitrate of segment mode and the position of excitations will be adapted. Through the encoding process, these models can describe the feature of data gradually. For the consistency, I use equal probability model to encode the other syntax so their bitrate is same as quantization. We also can know from the table that most bits of the predictor description coming from the excitations. Finally, if we want to integrate the new intra-prediction mode with current intra prediction modes in H.264, we will spend 1 more bit at macroblock level.

Smooth segment

Header \ Cost	Mode	Mean value
reducible	no	yes
Current bits	adaptive	4

Textured segment

Header \ Cost	Mode	LPC (order 1)	Excitation position	Maximal excitation	Excitation value
reducible	no	yes	yes	yes	
Current bits	adaptive	3	adaptive	5	8

Table 4 bitrate allocation of proposed intra prediction

Chapter 6. Experimental Results

Two 512x512 images (Lena, baboon) and four CIF sequences are tested using my proposed intra prediction (flower.cif, foreman.cif, Stefan.cif, mobile.cif). In this chapter, I will present the comparison of predictor quality and then show the bitrate of predictor description and residual information. Section 6.1 shows the subjective quality of intra prediction and compares our method with H.264. Section 6.2 reveals the average bits allocation of our predictor description. And the average objective quality is also shown in this section. I also compare the performance with JPEG, and the section 6.3 shows experiment results.

6.1. Subjective predictor quality

From the figures below, it reveals that our proposed method predicts well at the textured area. The date in the calendar is more clearly and blocking artifact is removed from the flower garden. We successfully catch the edge or pattern in the image by optimal excitation down-sampling. Following figures from **Fig. 27** to **Fig. 30** show the prediction results.



Fig. 27 mobile: left figure is our proposed predictor, 23.6dB; right figure is H.264 intra predictor, 17.9dB

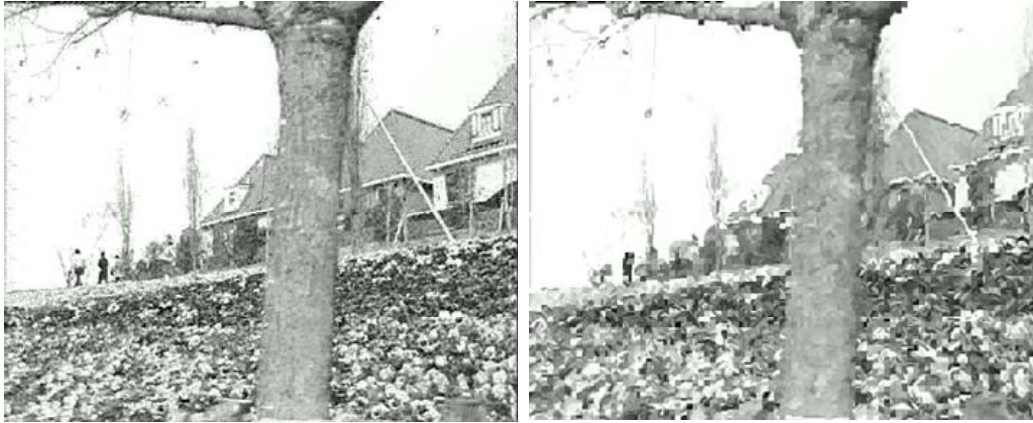

Fig. 28 flower: left figure is our proposed predictor, 23.4dB; right figure is H.264 intra predictor, 16.7dB



Fig. 29 Stefan: left figure is our proposed predictor, 25.9dB; right figure is H.264 intra predictor, 19.8dB



Fig. 30 foreman: left figure is our proposed predictor, 28.6dB; right figure is H.264 intra predictor, 27.6dB

6.2. Predictor bitrate and predictor quality

Table 5 and **Table 6** shows the header cost of our proposed intra prediction method, and the predictor quality of 4 video sequences. From the **Table 6**, our

proposed method has more than 5 dB better prediction quality compared to H.264, except foreman.cif. Our prediction method is not good enough for the smooth video content because we only using mean prediction. However, H.264 predicts the current macroblock by accessing neighboring macroblocks as references, so H.264 can achieve higher prediction accuracy for smooth area. Current predictor structure allocate much bits for better prediction but bits allocation cannot be adjusted according to different quantization scale. This design cause our coding performance will be worse for low bitrate video.

Sequence	mobile	flower	foreman	Stefan
Kbits/frame	119.4	130.1	62.1	110.4

Table 5 header cost of proposed intra prediction

Sequence	mobile	flower	foreman	Stefan
Proposed	23.58	22.93	27.89	25.91
H.264	17.95	16.69	26.76	20.04

Table 6 average intra predictor quality (dB)

6.3. Performance comparisons

Four 352x288 size images and two 512x512 size images are tested by different coding algorithms, and the below figures show the coding performance of JPEG, H.264, and our proposed method. From the experiment results, the performance of our proposed method is similar to JPEG for video quality is lower than 40dB. Our method can outperform JPEG and H.264 intra for very high bitrate and complex video. Because JPEG2000 is a little worse than H.264, and outperform than JPEG, we only compare three algorithms in this experiment.

The bitrate allocation of our proposed prediction method is one of the main reasons why our performance is bad. Current prediction algorithm doesn't take rate

control into consideration so prediction cost is always fixed no matter how the quantization scale changed. However, the current H.264 intra coding only uses nearly 3 KB to describe the predictor of 352x288 image. On the other hand, we can know that this excitation-based linear prediction algorithm is suitable for the complex repeated video content. If the video content is smooth, the original design of H.264 intra-frame coding is sufficient.

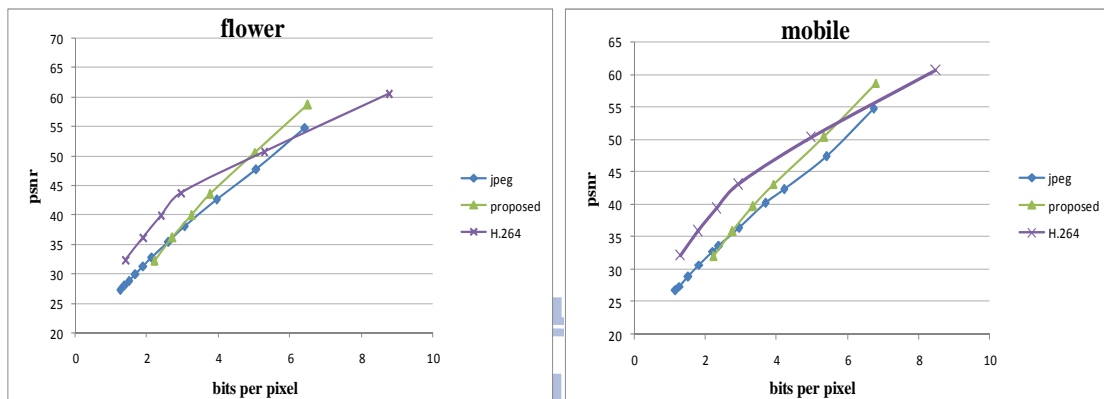

Fig. 31 flower, mobile coding performance

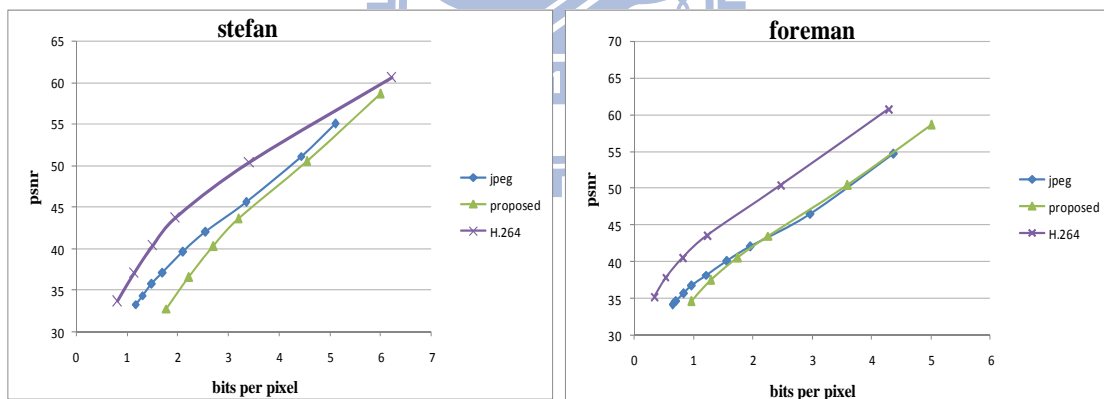

Fig. 32 stefan, foreman coding performance

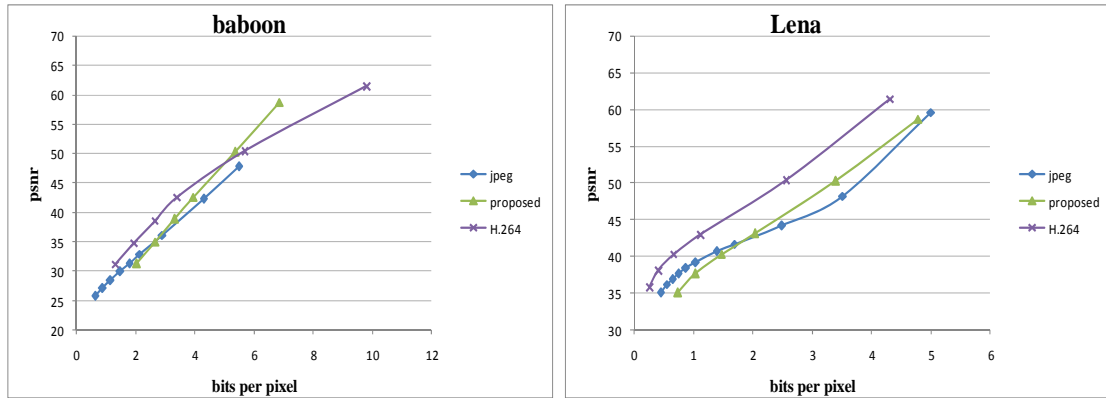

Fig. 33 baboon, Lena coding performance



Chapter 7. Conclusions and Future Work

From the previous experiments, excitation-based linear prediction is applicable to the complex repeated patterns compared to the block-based prediction of H.264. The edge and texture in the images can be described with optimal excitation selection. Although the performance of our proposed method is worse under common video bitrate, it has outperformed the H.264 for very high bitrate videos.

The entropy coder at H.264 is reused for residual coding, but the current entropy coder is not suitable for my proposed method. So the overall performance is not better than H.264 mainly due to the entropy coding. Although my proposed intra-prediction method has higher prediction quality than the original method in H.264, the entropy codec should be redesigned to enhance the overall performance. And the current bitrate allocation for the intra predictor still can be decreased by more efficient excitation coding method. The bits allocation of predictor also should be adapted at different bitrate. In the future, non-linear prediction can be involved to current prediction structure.

References

- [1] A. S. Lewis and G. Knowles, "Image Compression using 2-D Wavelet Transform," *IEEE Trans. Image Process.*, vol. 1, no. 2, pp. 244-250, Apr. 1992.
- [2] Z. Xiong, K. Ramchandran, M. T. Orchard, and Y.Q. Zhang, "A Comparative Study of DCT- and Wavelet-Based Image Coding," *IEEE Trans. Circuits, Syst. Video Techn.*, vol. 9, pp. 692–695, Aug. 1999.
- [3] I.K. Kim and R.H. Park, "Still Image Coding Based on Vector Quantization and Fractal Approximation," *IEEE Trans. Image Process.*, vol. 5, no. 4, pp. 589-597, 1996.
- [4] Z. Wang, A.C. Bovik, H.R. Sheikh, and E.P. Simoncelli, "Image Quality Assessment: From Error Visibility to Structural Similarity," *IEEE Trans. Image Process.*, vol. 13, no. 4, pp. 600-612, Apr. 2004.
- [5] G. K. Wallace, "The JPEG Still Picture Compression Standard," *Commun. ACM*, vol. 34, pp. 30-44, Apr. 1991.
- [6] *Information technology — Lossless and near-lossless compression of continuous-tone still images*, ISO/IEC 14495–1 and ITU Rec. T.87, 1999.
- [7] D. S. Taubman and M. W. Marcellin, "JPEG 2000: Standard for Interactive Imaging," *Proc. IEEE*, vol. 90, no. 8, pp. 1336-1357, Aug. 2002.
- [8] K. Varma, A. Bell, "JPEG2000-Choices and Tradeoffs for Encoders," *IEEE Signal Process. Mag.*, no. 11, pp. 70-75, Nov. 2004.
- [9] Iain E. G. Richardson, *Video Codec Design*, John Wiley & Sons Ltd, 2002.
- [10] Iain E. G. Richardson, *H.264 and MPEG-4 Video Compression: Video Coding for Next Generation Multimedia*, John Wiley & Sons Ltd, 2003.
- [11] "Draft ITU-T Recommendation and Final Draft International Standard of Joint

- Video Specification (ITU-T Rec.H.264/ISO/IEC 14 496-10 AVC),” in Joint Video Team (JVT) of ISO/IEC MPEG and ITU-T VCEG, Apr. 2005.
- [12] D. Marpe, H. Schwarz, and T. Wiegand, “Context-Based Adaptive Binary Arithmetic Coding in the H.264/AVC Video Compression Standard”, *IEEE Trans. on CSVT*, vol. 13, Issue 7, pp. 620-636, Jul. 2003.
- [13] A. Al, B. P. Rao, S. S. Kudva, S. Babu, D. Suman, and A. V. Rao, “Quality and Complexity Comparison of H.264 Intra Mode with JPEG2000 and JPEG,” *Proc. IEEE Int. Conf. Image Processing*, vol. 1, pp. 525-528, Singapore, Oct. 2004.
- [14] Boxin Shi , Lin Liu, and Chao Xu , “Comparison Between JPEG2000 and H.264 For Digital Cinema,” *Proceeding of ICME*, pp. 725-728, Hannover, Germany, Apr. 2008.
- [15] T. Wiegand, G. J. Sullivan, G. Bjontegaard, and A. Luthra, “Overview of the H.264/AVC Video Coding Standard,” *IEEE Trans. Circuits Syst. Video Technol.*, vol. 13, pp. 560–576, July 2003.
- [16] J. S. Park and H. J. Song, ”Selective Intra Prediction Mode Decision for H.264/AVC Encoders,” *Transactions on Engineering, Computing and Technology*, vol. 13, pp.51-55, May 2006.
- [17] B. Meng and O. C. Au, “Fast Intra-Prediction Mode Selection for 4x4 Blocks in H.264,” *Proc. of IEEE Int. Conf. on Acoustics, Speech, and Signal*, vol. 3, pp. III - 389 – 92, Hong Kong, China, 2003.
- [18] C. C. Cheng and T. S. Chang, “Fast Three Step Intra Prediction Algorithm for 4x4 Blocks in H.264,” *IEEE Int'l Symp. on Circuits and Systems*, vol. 2, pp. 1509 -1512, 2005.
- [19] D. Liu, X. Sun, F. Wu, and Y.Q. Zhang, “Edge-Oriented Uniform Intra Prediction,” *IEEE Trans. Image Process.*, vol.17, pp. 1827-1836, Oct. 2008.
- [20] L. Liu, “Multiple Predictor Sets for Intra Coding,” Joint Collaborative Team on

- Video Coding, input doc. JCTVC-A022, Dresden, Germany, Apr. 2010.
- [21] C.C. Lai, Y.B. Lin, "New intra prediction using the correlation between pixels and lines," Joint Collaborative Team on Video Coding, input doc. JCTVC-A025, Dresden, Germany, Apr. 2010.
- [22] Wai C. Chu, *Speech Coding Algorithms: Foundation and Evolution of Standardized Coders*, John Wiley & Sons, Inc., 2003
- [23] Digital Cellular Telecommunications System (Phase 2+), "Full rate speech transcoding (GSM06.10 version)," ETSI, 1988.
- [24] D.J. Abel, D.M. Mark, "A Comparative Analysis of Some Two-Dimensional Orderings," *Int'l J. Geographical Information science*, vol. 4, no. 1, pp. 21-31, Jan. 1990.
- [25] H.V. Jagadish, "Linear Clustering of Objects with Multiple Attributes," *Proc. ACM SIGMOD Conf.*, pp. 332-342, New York, USA, May 1990.
- [26] B. Moon, H. V. Jagadish, C. Faloutsos, and J. H. Saltz, "Analysis of the Clustering Properties of the Hilbert Space-Filling Curve," *IEEE Trans. on Knowledge and Data Eng.*, vol. 13, no. 1, pp. 124-141, Jan. 2001.
- [27] W. K. Cham, "Development of Integer Cosine Transforms by the Principle of Dyadic Symmetry," *IEE Proceedings*, vol. 136, pp. 276-282, Aug. 1989.
- [28] W.K. Cham and R.J. Clarke, "Dyadic Symmetry and Walsh Matrices," *IEE Proc. Commun., Radar & Signal Process.*, vol. 134, no. 2, pp. 141-144, 1987.
- [29] W.K. Cham and R.J. Clarke, "Application of the Principle of Dyadic Symmetry to the Generation of Orthogonal Transforms," *IEE Proc. F, Commun., Radar & Signal Process.*, vol. 133, no. 3, pp.264-270, 1986.
- [30] J. Heo, S.H. Kim, and Y.S. Ho, "New CAVLC Design For Lossless Intra Coding," *Proc. IEEE Int. Conf. Image Processing*, pp.637-640, Cairo, Egypt, 2009 16th.

- [31] G. J. Sullivan, “Adaptive Quantization Encoding Technique Using an Equal Expected-Value Rule,” Joint Video Team (JVT) of ISO/IEC MPEG & ITU-T VCEG, input doc. JVT-N011, Hong Kong, China, Jan. 2005.
- [32] David Singer, “What can we do about interlace?” ISO/IEC 90th MPEG meeting input contribution: m17005, Xian, China, 2009.

