

Full duplex 60-GHz RoF link employing tandem single sideband modulation scheme and high spectral efficiency modulation format

Po-Tsung Shih¹, Chun-Ting Lin^{2,*}, Wen-Jr Jiang¹, Yu-Hung Chen¹,
Jason (Jyehong) Chen¹, and Sien Chi³

¹Department of Photonics and Institute of Electro-Optical Engineering, National Chiao-Tung University, Hsinchu, Taiwan 300, R.O.C.

²Institute of Photonic System, National Chiao-Tung University, Tainan Taiwan 711, ROC.

³Department of Photonics Engineering, Yuan-Ze University, Chung Li, Taiwan 320, R.O.C.
*jinting@mail.nctu.edu.tw

Abstract: This study proposes a full duplex 60-GHz band radio-over-fiber (RoF) link using a modified tandem single sideband (TSSB) modulation scheme with frequency doubling. Based on the modified TSSB modulation scheme, no dispersion induced fading is observed; high spectral efficiency vector signal can be utilized; and wavelength reuse can also be achieved. Both single carrier 8-QAM and QPSK-OFDM signals for down-link transmissions are experimentally demonstrated. After transmission of 50-km SSMF, no significant receiver power penalties are observed. Wavelength reuses with 1.25-Gb/s OOK using a reflective semiconductor optical amplifier (RSOA) for up-link transmission are also demonstrated. After transmission of 50-km SSMF, no significant receiver power penalties are also observed.

©2009 Optical Society of America

OCIS codes: (060.2330) Fiber optics communications; (060.2360) Fiber optics links and subsystems.

References and links

1. <http://www.wirelessHD.org>
2. Y. X. Guo, B. Luo, C. S. Park, L. C. Ong, M.-T. Zhou, and S. Kato, "60 GHz Radio-over-Fiber for Gbps Transmission." Proceedings on Global Symposium on Millimeter Waves (GSMM), Invited paper (2008).
3. H. C. Chien, A. Chowdhury, Z. Jia, Y. T. Hsueh, and G. K. Chang, "60 GHz millimeter-wave gigabit wireless services over long-reach passive optical network using remote signal regeneration and upconversion," *Opt. Express* **17**(5), 3016–3041 (2009).
4. L. Chen, J. G. Yu, S. Wen, J. Lu, Z. Dong, M. Huang, and G. K. Chang, "A Novel Scheme for Seamless Integration of ROF With Centralized Lightwave OFDM-WDM-PON System," *J. Lightwave Technol.* **27**, 2786–2791 (2009).
5. M. Weiß, A. Stöhr, M. Huchard, S. Fedderwitz, B. Charbonnier, V. Rymanov, S. Babel, and D. Jäger, "60GHz Radio-over-Fiber Wireless System for Bridging 10Gb/s Ethernet Links," Proceedings of European Conference on Optical Communication (ECOC), Brussels, Tu.3.F.6 (2008).
6. C. Wu, and X. Zhang, "Impact of Nonlinear Distortion in Radio Over Fiber Systems With Single-Sideband and Tandem Single-Sideband Subcarrier Modulations," *J. Lightwave Technol.* **24**(5), 2076–2090 (2006).
7. C. T. Lin, P. T. Shih, Y. H. Chen, W. J. Jiang, J. Chen, and S. Chi, "Experimental Demonstration of 10-Gb/s OFDM-QPSK Signal at 60GHz Using Frequency-Doubling and Tandem SSB Modulation," Proceedings of Optical Fiber Communication Conference (OFC), San Diego, OMV7 (2009).
8. A. Ng'oma, M. Sauer, J. George, and D. Thelen, "Bit-Rate Doubling in Multi-Gbps Wideband ASK-Modulated 60 GHz RoF Links using Linear Feed-Forward Equalisation and Direct Conversion," Proceedings of European Conference on Optical Communication (ECOC), Brussels, P612, (2008).
9. C. Lim, M. Attygalle, A. Nirmalathas, D. Novak, and R. Waterhouse, "Analysis of optical carrier-to-sideband ratio for improving transmission performance in fiber-radio links," *IEEE Trans. Microw. Theory Tech.* **54**(5), 2181–2187 (2006).

1. Introduction

With the release of 7-GHz license-free band, 60-GHz wireless communication system has become a potential candidate for future broadband wireless access network system. 60-GHz

wireless standards, such as IEEE 802.15 WPAN (wireless personal area network), IEEE 802.16 WiMAX, and wireless high definition video services (WirelessHD), have been proposed [1]. Nevertheless, the transmission distance of 60-GHz wireless signal is limited by the high path and atmospheric losses. To extend the coverage of 60-GHz wireless signal, radio-over-fiber (RoF) technique becomes a promising solution because of the low transmission loss and unlimited bandwidth of optical fibers [2–5].

However, 60-GHz optical vector signal generation still remains a great challenge. Generation and transmission of high throughput 60-GHz optical signals have been widely investigated [2–5, 7]. Using electro-absorption-modulator (EAM) is one of the reliable solutions [2]. Because of the high bandwidth of EAM, 60-GHz signals can directly drive the EAM. Since no frequency multiplication is achieved when an EAM is utilized with double sideband (DSB) scheme, 60-GHz driving equipments and components are required. Moreover, the generated DSB signal suffers from the dispersion-induced performance fading varied with fiber transmission length. To generate 60-GHz millimeter-wave signal with frequency doubling and overcome the dispersion-induced performance fading issue, double sideband with carrier suppression (DSB-CS) modulation scheme using Mach-Zehnder modulators (MZM) are proposed [3–5]. However, low spectral efficiency on-off-keying (OOK) modulation format is generally utilized in DSB-CS modulation scheme [3–5]. To satisfy the desire of high data rate transmission within the 7-GHz license-free band, high spectral efficiency vector signal generation is highly preferred [1].

Recently, RoF signal generation using tandem single sideband (TSSB) modulation scheme utilizing a dual-electrode MZM has been proposed [6, 7]. The generated TSSB optical signal is composed of one original optical carrier and two optical sidebands. After the removing of the original optical carrier, the 60-GHz RoF signal can be obtained from beating of two optical sidebands. If one of two generated optical sidebands is un-modulated, the proposed modified TSSB scheme can support optical vector signals. Based on the modified TSSB modulation scheme, high spectral efficiency vector signal can be used, and frequency doubling can be achieved. Moreover, there is no dispersion-induced performance fading.

In this work, a full duplex modulation technique for 60-GHz RoF system based on modified TSSB scheme is proposed. Both 2.34375-Gb/s 8-quadrature amplitude modulation (8-QAM) signal and 13.75-Gb/s QPSK orthogonal frequency division multiplexing (OFDM) signal for down-link transmission are experimentally demonstrated. However, the frequency response of the 60-GHz components is usually uneven, which introduces distortions to the signals. To compensate for the uneven frequency responses, feed-forward equalizer (FFE) [8] is utilized in the 8-QAM system to improve the receiver performance. Because of the multi-carrier characteristic of the OFDM signal, one-tap equalizer is used to overcome the uneven

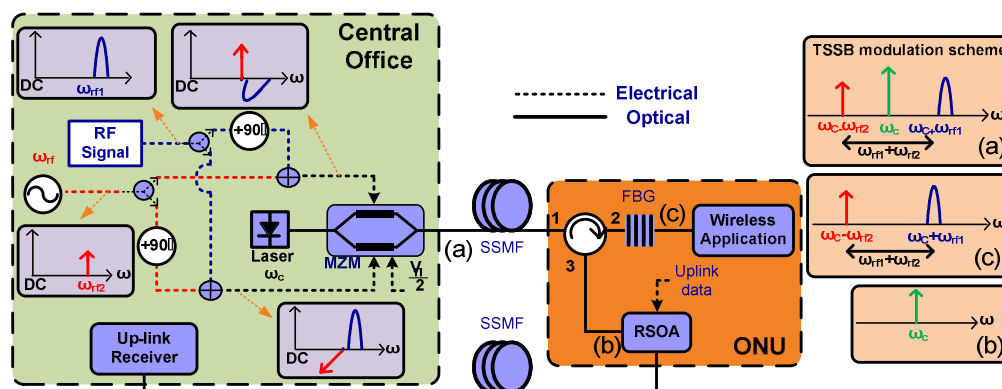

Fig. 1. Conceptual diagram of the TSSB system

frequency response of the 60-GHz receiver system. After the transmission of 50-km standard single mode fiber (SSMF), negligible receiver sensitivity penalty for both down-link signals are observed. Wavelength reuse of the original optical carrier for up-link transmission using reflective semiconductor optical amplifier (RSOA) with 1.25-Gb/s on-off-keying (OOK) signals are experimentally demonstrated. After the transmission of 50-km SSMF, no significant receiver sensitivity penalty is also observed.

2. Concept

Figure 1 shows the conceptual diagram of the proposed TSSB modulation system employing a dual-electrode MZM biased at the quadrature point. To perform a data-modulated upper optical sideband and an un-modulated lower optical sideband, two additional 90° phase shifts are added on the upper path of the radio frequency (RF) data signal and lower path of the sinusoidal signal, respectively. The RF data signal and sinusoidal signal are then combined and sent into the dual-electrode MZM. At the output of the MZM, a TSSB optical spectrum which consists of the original optical carrier (ω_c), the data-modulated optical sideband ($\omega_c + \omega_{rf1}$), and the un-modulated optical sideband ($\omega_c - \omega_{rf2}$) are obtained, as shown in inset (a) of Fig. 1. At the remote node, following the transmission of SSMF, a fiber Bragg grating (FBG) and an optical circulator are employed to separate the original optical carrier (ω_c) from the other two sidebands, as shown in insets (b) and (c) of Fig. 1. The original optical carrier is utilized for uplink application employing a bias-modulated RSOA. The un-modulated and data-modulated optical sidebands are received for RoF applications. When $\omega_{rf1} = \omega_{rf2}$, frequency doubling can be achieved. In OFDM systems optical power ratio (OPR) between the un-modulated and data-modulated optical sidebands is an important factor for receiver performance optimization. Since the un-modulated and data-modulated optical sidebands are generated from two individual driving signals, the OPR can be freely adjusted for receiver performance optimization. Based on the modified single sideband (SSB) modulation scheme, high spectral efficiency vector signals can be utilized, and no dispersion induced performance fading issue is observed in the proposed system.

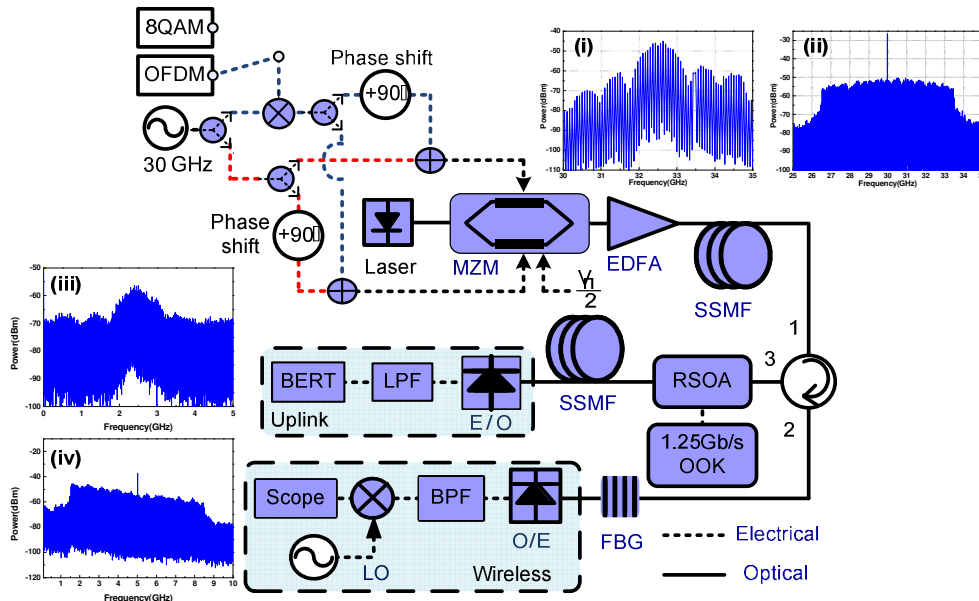

Fig. 2. Experimental setup of the proposed system and the electrical spectra.

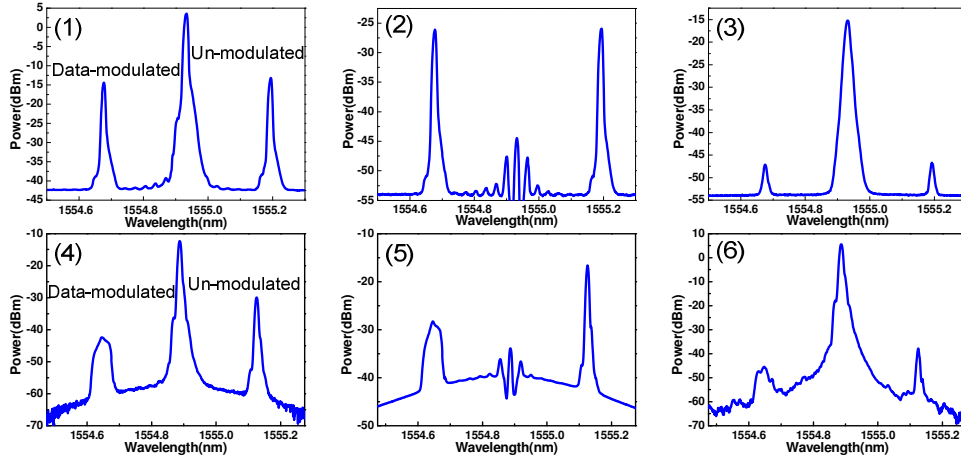

Fig. 3. Optical spectra generated for the proposed 8-QAM and OFDM TSSB system. (Resolution bandwidth 0.01 nm)

3. Experimental setup and results

To perform high spectral efficiency modulation within the 7-GHz license-free band at 60-GHz, single-carrier 8-QAM and multi-carrier QPSK-OFDM modulation formats are experimentally demonstrated. To compensate for the uneven frequency response of the 60-GHz components, FFE is utilized in 8-QAM system. Nevertheless, with the increasing of the bandwidth of the single carrier 8-QAM signal, efficiency of FFE is reduced and transmission with data rate beyond 10 Gb/s cannot be easily achieved. Multi-carrier OFDM is a potential solution for the high throughput transmission. One-tap equalizer can compensate for the uneven frequency response of a wideband signal. Therefore, the 7-GHz license-free band can be used efficiently.

3.1 8-QAM system experimental setup

Figure 2 illustrates the experimental setup of the proposed full-duplex system. A tunable laser is employed as the optical source. The 8-QAM is generated from the arbitrary waveform generator (AWG) with 2.34375-Gb/s data rate and 2.5-GHz carrier frequency. The sampling rate of the AWG is 10 GHz. The 8-QAM signal is up-converted to 32.5 GHz using an electrical mixer with a 30-GHz RF local oscillator (LO) signal. Inset (i) of Fig. 2 shows the electrical spectrum of the up-converted 8-QAM signal. Both 32.5-GHz 8-QAM and 30-GHz sinusoidal signals are divided into two paths using two 90° hybrid couplers. The combined signals are amplified to drive the dual-electrode MZM. At the output of the MZM, an erbium doped fiber amplifier (EDFA) is employed to boost the optical power before fiber transmission. The optical spectrum generated from the MZM is shown in the inset (1) of Fig. 3. After filtering out the original optical carrier at remote node, the inset (2) of Fig. 3 shows the optical spectrum composed of the un-modulated and data-modulated optical sidebands. The inset (3) of Fig. 3 shows the optical spectrum of the original optical carrier. The un-modulated and data-modulated optical sidebands are sent into a V-band photo-diode (PD). The 62.5-GHz 8-QAM signal is obtained and down-converted to 2.5 GHz using an electrical mixer with a 60-GHz RF LO signal, as shown in inset (iii) of Fig. 2. The down-converted 2.5-GHz 8-QAM signal with 8192 symbols is sent into a digital signal oscilloscope to capture the time domain waveform. Off-line digital signal processing (DSP) programs are employed to demodulate the 8-QAM signal. To compensate the 60-GHz uneven frequency response, FFE with 16 taps is employed. Error vector magnitude (EVM) is utilized for the 8-QAM signal

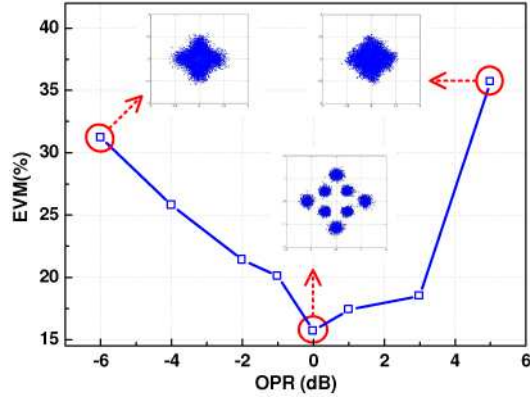

Fig. 4. Optical power ratio versus EVM of the 8-QAM signals with FFE

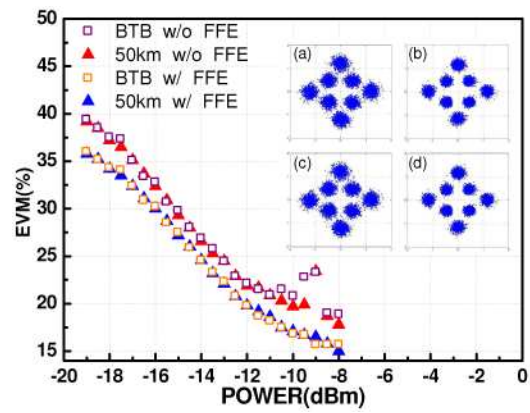

Fig. 5. EVM curves of the 8-QAM signals and constellation of the 8-QAM signals. (a) BTB w/o FFE; (b) BTB w/ FFE; (c) 50km w/o FFE; (d) 50km w/ FFE.

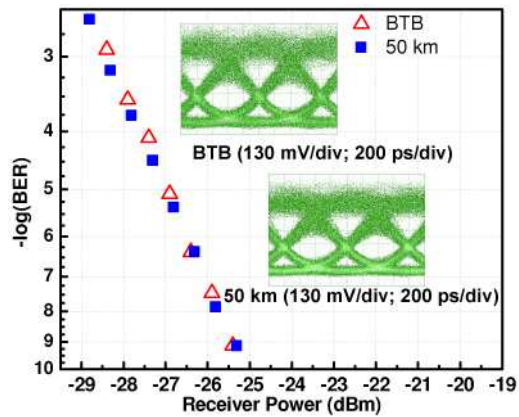

Fig. 6. BER curves of the 8-QAM system uplink 1.25-Gb/s OOK signals

performance evaluation. The EVM is defined as $EVM[\%] = 100 \times \left[\sum_{i=1}^N |\overline{d}_r - d_i|^2 / N \right]^{1/2} / |d_{\max}|$ Where \overline{d}_r and d_i are the received and ideal symbols, respectively, and d_{\max} is the maximum symbol vector in the constellation.

3.2 8-QAM system experimental results

The un-modulated optical sideband to data modulated sideband OPR is an important factor which affects the receiver performance. In conventional SSB modulation scheme, the OPR cannot be easily adjusted. An addition narrow band optical filter is usually required to suppress the original optical carrier and improve the receiver performance in conventional SSB system [9]. In the proposed TSSB system, the un-modulated and data-modulated optical sidebands are generated from two individual driving signals. Therefore, the OPR can be adjusted by controlling the amplitude of the driving signals. Figure 4 shows the EVM versus OPR curve with FFE. The best receiver performance is observed when the OPR is equal to 0 dB, where the optical powers of the un-modulated and data-modulated sidebands are equal. The optical powers of the optical sidebands are obtained from the integration of the optical spectrum. The constellation diagrams with 5 dB, 0 dB, and -6 dB OPR are also shown in the insets of Fig. 4.

Figure 5 shows the down-link EVM versus optical received power. Before FFE, there is an EVM fluctuation due to receiver saturation with the increasing of the received optical power. However, the FFE can compensate not only the uneven frequency response but also the receiver saturation. After the FFE, the EVM is improved from 18.9% to 15.7% with -8-dBm optical power. After transmission of 50-km SSMF, the received power penalty can be ignored. The EVM and constellation of the transmitted signal are also improved after the FFE. The insets (a) and (c) of Fig. 5 show the constellation diagrams of the 8-QAM signals at back to back (BTB) and after transmission without FFE, respectively. The BTB and transmitted signal

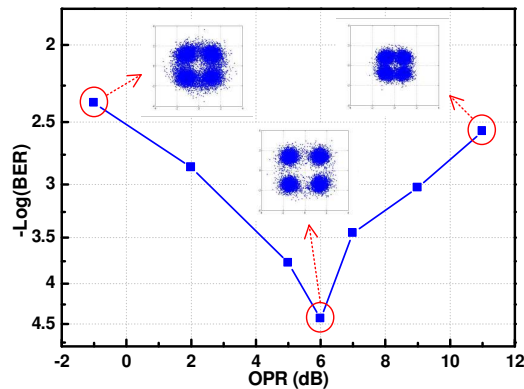

Fig. 7. Optical power ratio versus $-\log(\text{BER})$ of the OFDM signal.

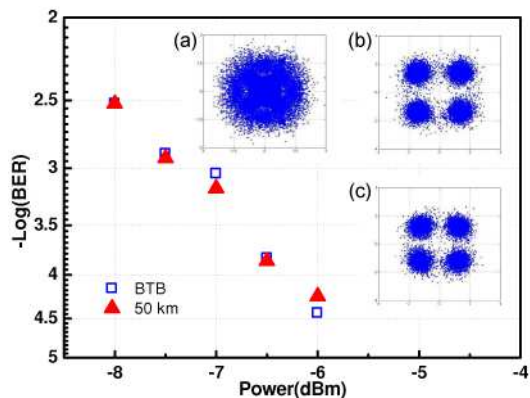

Fig. 8. BER curves and constellation diagrams of the down-link transmission. (a) Back to back without one-tap equalizer; (b) back to back with one-tap equalizer; (c) 50-km SSMF.

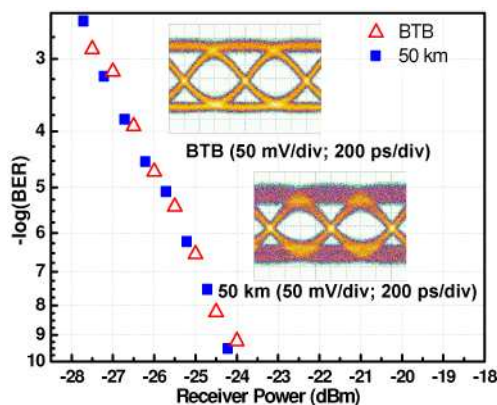

Fig. 9. BER curves of the OFDM system uplink 1.25-Gb/s OOK signals.

constellation diagrams with FFE are also shown in insets (b) and (d) of Fig. 5, respectively. After transmission of 50-km SSMF, no significant distortion is observed at the constellations. Figure 6 shows the experimental results of the up-link transmission. The RSOA is bias-modulated with a 1.25-Gb/s OOK signal which is generated from a pattern generator. After the transmission of 50-km SSMF, the bit error rate (BER) of the uplink signal is analyzed directly using a bit error rate tester (BERT). The eye diagrams of the OOK signal at BTB and after transmission are also shown in the insets of Fig. 6. After 50-km SSMF transmission, there is no significant receiver power penalty of the OOK uplink signal, and the eye diagram is still very clear.

3.3 OFDM system experimental setup

To performance the 60-GHz OFDM full-duplex system, experimental setup as shown in Fig. 2 is utilized again. However, the down-link signal is switched to a QPSK-OFDM signal. The QPSK-OFDM signal is generated from the AWG with the following parameters: the digital to analog converter (DAC) sampling rate is 20 GHz; inverse-fast-Fourier transform (IFFT) size is 256; subcarrier frequency separation is 78.125 MHz; 44 subcarriers are generated at baseband. After up-conversion using an electrical mixer with 30-GHz sinusoidal signal, a 30-GHz QPSK-OFDM driving signal with 88 subcarriers is obtained as shown in inset (ii) of Fig. 2. The bandwidth and data rate of the 30-GHz QPSK-OFDM signal is 7 GHz and 13.75 Gb/s, respectively. The OFDM driving signal is divided using a 90° hybrid coupler and combined with 30-GHz driving signals to drive the dual-electrode MZM which is biased at quadrature

point. The generated TSSB OFDM signal is transmitted over 50-km SSMF, and an optical fiber Bragg grating is utilized to separate the original optical carrier and two optical sidebands for up-link and down-link application, respectively. The two optical sidebands are received using a V-band PD for optical-electrical conversion. The generated optical spectrum of TSSB OFDM signal and the optical spectra of the signals after filtering are also shown in inset (4)-(6) in Fig. 3. Different from the optical spectra of the signal-carrier 8-QAM system, data-modulated sideband with wider bandwidth can be observed. The generated 60-GHz OFDM signal are down-converted using an electrical mixer with 55-GHz LO signal, and sent into a digital signal oscilloscope to capture the time domain waveform for off-line demodulation. The demodulation process includes synchronization, fast-Fourier transform (FFT), one-tap equalizer, and QPSK demodulator. Based on the multi-carrier characteristic of the OFDM signal, one-tap equalizer can efficiently compensate the uneven frequency response of the 60-GHz components. Bit error rate (BER) estimation from the constellation diagrams are utilized for signal performance evaluation.

3.4 OFDM system experimental results

Figure 7 shows the QPSK-OFDM BER versus OPR curves. Different from the single carrier 8-QAM system, the best receiver performance is obtained with 6-dB OPR. The constellation diagrams with OPRs of -1dB, 6dB and 11 dB are also shown in the insets of Fig. 7. Compared with signal carrier 8-QAM system, the OPR in OFDM systems are higher. Due to the high peak-to-average-power-ratio (PAPR) property, OFDM signals are sensitive to the nonlinearity of the transmission systems, and the signal performance can be easily degraded. Therefore, properly increasing the optical power of the un-modulated optical sideband can overcome the signal performance degradation. Figure 8 shows the BER curves and constellation diagrams of the 13.75-Gb/s QPSK OFDM down-link signals. Without using the one-tap equalizer, the OFDM signal cannot be recovered due to uneven frequency and phase response at 60 GHz as shown in the inset (a) of Fig. 8. After using the one-tap equalizer, the QPSK-OFDM signal can be recovered. No significant signal distortion of the constellation diagram is observed after transmission of 50-km SSMF. The receiver power penalty after the SSMF transmission can be ignored. Figure 9 shows the BER curves of the up-link 1.25-Gb/s OOK signal signals using a bias modulated RSOA. No significant receiver power penalty is observed after 50-km SSMF transmission. The eye diagrams of the OOK signals are also shown in the inset of Fig. 9. The eye diagram is also very clear after 50-km SSMF transmission.

4. Conclusion

A full duplex modulation technique utilizing TSSB scheme for 60-GHz RoF system is proposed in this work. Frequency doubling, high spectral efficiency vector signal, and full-duplex systems are achieved. Furthermore, the proposed system does not suffer from dispersion induced performance fading issue. Both 2.34375-Gb/s 8-QAM and 13.75-Gb/s QPSK OFDM signals are experimentally demonstrated. To compensate the uneven frequency response of the 60-GHz RF components, FFE with 16 taps and one-tap equalizers are utilized in the 8-QAM and OFDM systems, respectively. After transmission of 50-km SSMF, no significant receiver power penalties are observed in both 8-QAM and OFDM systems. Wavelength reuse using RSOAs for uplink transmissions are also experimentally demonstrated. 1.25-Gb/s OOK signal are modulated on the original optical carrier and transmitted over 50-km SSMF. No significant receiver power penalty of the uplink signal is observed on the uplink signal.

Acknowledgment

This work was supported by the National Science Council of the Republic of China, Taiwan, under Contract NSC-98-2221-E-155-003-MY3, Contract NSC-98-2221-E-155-004-MY3, Contract NSC-96-2628-E-009-016-MY3, and Contract NSC-96-2628-E-009-016-MY3.