

A Real-Time Driving Assistance and Surveillance System*

CHAO-JUNG CHEN, HSIN-YUAN PENG, BING-FEI WU AND YING-HAN CHEN

Department of Electrical and Control Engineering

National Chiao Tung University

Hsinchu, 300 Taiwan

Thousands of people are killed or injured in the vehicle accidents which are mostly caused by the carelessness of humans. Therefore, if there exists a warning system which can notify the driver of the approaching vehicles and the lane departure, the terrible tragedies can be greatly avoided. Moreover, if the driving status, such as the situation around the vehicle and the drivers' behaviors, can be recorded in videos, not only in texts, the police officers can reconstruct the scene easily. Furthermore, the increasing numbers of stolen cars is an important issue so the protection of the vehicles is essential. In this paper, a real-time DSP-based driving assistance and surveillance system is proposed. It can manipulate the images to detect the lane and the vehicles in both front and rear directions and the full-time driving status can also be recorded in H.264. After the car is parked, the monitor images inside the vehicle can be transmitted to users' mobile phones. The contribution of this paper is to provide an embedded system to improve the security at all-time, and the drivers, the passengers, and the vehicles can be much safer. The proposed system has been successfully implemented and fully tested by the real road environment in Taiwan so the stability and the reliability can be ensured.

Keywords: driving assistance, lane departure, vehicle detection, driving recorder, mobile surveillance recorder, intelligent transportation systems

1. INTRODUCTION

Recently, the death rate of traffic accidents has a huge increasing, and about 800,000 people died in world-wide road related accidents in 1999 [1]. According to the report by the U.S. National Highway Traffic Safety Administration (NHTSA), falling asleep while driving is responsible for at least 100,000 automobile troubles annually [2]. In 2000, the situation even got worse, and 1.26 million people are killed in the tragedies [3]. From the above statistical results, the terrible disasters have been increased dramatically, and the driving behavior is the main reason. The misfortunes can be avoided if the drivers are notified with the real-time warning messages by the driving assistance system (DAS) in a jiffy. Thus, many researchers focus on the developments of DAS to solve these huge problems [4-8]. One kind of these systems needs several instruments except cameras to deal with the input information [4-6]. Wijesoma *et al.* use radar to scan the lane status [4]. If the driving conditions are classified as the irregular cases, the system will trigger the warning messages. Besides, the car accidents are not only caused by the lane departure, but also by the inappropriate distances between vehicles. DDAS, proposed by Sheu *et al.*, is able to provide useful surrounding information, such as directions and distances to nearby vehicles, to drivers, so unnecessary collisions could be

Received November 21, 2007; revised April 29, September 4 & October 20, 2008; accepted November 12, 2008. Communicated by Tei-Wei Kuo.

* This paper was supported by National Science Council under grand No. NSC 97-2752-E-009-003-PAE.

avoided, especially in cases of changing lanes, crossing intersections, and making turns [5]. The main idea of [5] is to install DDAS in all cars, so the vehicles can detect each other by the smart antennas to exchange the data to maintain the proper behaviors. However, these systems may not be practical since they need more instruments to detect the lanes and the vehicles, and it will lead to increase the cost and the limitation compared to the general image-based processing system. Moreover, in the advanced safety vehicles (AVS) project of Toyota, the driver must wear a wristband in order to measure his heart rate, and Mitsubishi has reported the use of steering wheel sensors to measure the vehicles' behavior to detect if the drivers drowse or not in their AVS system [6].

Other methods are based on the employment of the machine vision, and they only require several cameras and the process units to compute the driving safety assist algorithms. Hayami *et al.* use eye's status to adjudge the drivers' behavior to distinguish whether they are drowsiness or not [7]. In the algorithm of [7], few parameters are roughly calculated so the precision is not good enough to provide the safety. In order to increasing the degree of accuracy and the robustness, more complex equations are calculated in [8]. Although the performance has been promoted, its computational complexity also increases comparatively. These methods can mainly solve the problems that the drivers fall in asleep, but not the ones caused by irregular driving behaviors. If the motorists are talking on the phones or having daydreams, they won't doze. However, the dangerous actions such as lane departure will be produced.

Several lane departure warning systems (LDWS) based on the variety of the computer vision techniques have been proposed [9-13]. The main principles of these different technologies are to detect whether the vehicles are in some risky conditions. When the systems find that the cars are in some irregular statuses, they will alarm the drivers by generating warning signals like making a huge sound or a blinking light. Most algorithms only can run on personal computers or workstations due to the complexity, and it is not acceptable in real applications such as buses, trucks and movable cars because of the limited space and the restricted power supplement. In order to avoid these drawbacks, the modified schemes for the embedded systems are proposed [14-16]. In [15], an ARM-based system is provided to act as an LDWS, and it has a major advantage of the cost and the power consumption. However, its performance is low, 128×128 at 22 frames per second (FPS). For the huge image information, a system adds field programmable gate array (FPGA) device to increase processing speed [14-16]. The quasi-system based on Power PC is also proposed [17], and it uses a powerful core and a small machine box to form a mini-system. Although these solutions can overcome the complicated computations and finish the particular works, the system is hard to change if users or programmers want to modify or add some functions in the future. For example, the system needs to modify the algorithms for the signs of velocity-limitation which are different in U.S.A. and Asia.

The above works are used to prevent the accidents, but they can not provide useful information for users and police officers when the misfortunes happen. The vehicle box, proposed by Yeh *et al.*, is designed to keep track of the vehicles and the driving information, which is analogous to the flight data recorder used in aircrafts [18]. Since it takes down the GPS data, it can reconstruct the car's location, speed, and orientation. However, it can not reveal the exact causes.

All of these works lack the real-time notification which can greatly help the drivers, and the driving status that can analyze the reasons of the accidents [4-18]. Moreover,

these systems can only protect the users and the vehicles when they are moving. When the vehicles are parked, the users still have to face the opportunity of missing them. In this study, a real-time digital signal processor (DSP) based driving assistance and surveillance system (DASS) is implemented. For the considerations in both flexibility and computing power, the DSPs with strong calculation, addition and multiplication, are good choices for the vehicular electronics. The system is combined by two independent DSP sub-systems, which are the lane departure and vehicle detection warning system, LVWS, and the mobile surveillance recorder, MSR, and is realized by TI DM642 and OMAP5912, respectively. The algorithms on LVWS work not only for the front view but also the rear direction, and can manipulate the real-time images from these two channels simultaneously in CIF at 30 frames per second. MSR is responsible for recording the full-time driving status with H.264 video compression algorithm, and it also provides the monitoring functionalities using cell phones. When the vehicle is driving away from the road or is too close to the other cars, LVWS will generate a warning signal and transmit it to MSR by the ZigBee wireless communication. The main advantages of using ZigBee are to simplify the installation of DASS and save the space which is strongly restricted in the vehicles. As soon as LVWS receives the caution information, it will produce short messages to the mobile phones of the related people, such as their families or companies. Then, they can browse the real-time images from MSR with their mobile phones anytime and anywhere and caution the driver or request the police for help in order to avoid a possible accident. Furthermore, if the motorist is in distress, the video recorded by MSR can help the police to recover the original condition. Furthermore, if the vehicle accident happened, such as dropping down the mountain valley or being capsizing, MSR will call for help automatically to reduce the waiting time and greatly increase the survival rate. Moreover, when the vehicles are parked, the owners can receive the images from MSR to protect their properties. The main contribution of this paper is to provide a total solution which integrates the innovative functions in an embedded system to furnish the users full-time protection. No matter the drivers, the passengers, and the vehicles are moving or not, their safety are ensured.

The rest of this paper is organized as follows. In section 2, the innovative functional schemes of DASS are presented. Section 3 describes the software of LVWS and MSR. Section 4 depicts the optimization methods of platform-dependent designs for DSPs. DASS is tested on different real conditions, and the relative results are shown in section 5. Finally, the conclusions are given in section 6.

2. THE INNOVATIVE FUNCTIONAL SCHEMES OF DASS

An overall system block diagram of DASS is depicted in Fig. 1. LVWS combines two cameras, a DM642 platform, and a ZigBee device. The cameras are responsible for capturing the real-time information and send them into DSP, and when the manipulation results determine that the vehicle is in danger, the warning signal will be transmitted to MSR via the ZigBee device. The major function of LVWS is to detect the lanes and the vehicles in both front and rear views. MSR includes a touch screen module, a USB camera, a CF storage card, and a 3.5G/3G module. The camera will capture the images in the vehicle, and the OMAP processor will compress them with the format of H.264 in the CF

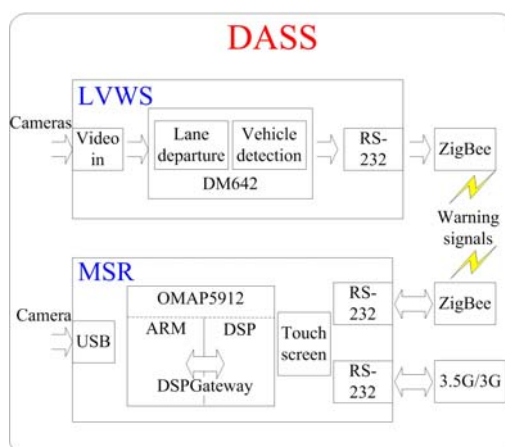

Fig. 1. An overall system block diagram of DASS.

storage card. When MSR receives the warning signal from LVWS, it will send the warning short message to the mobile phones that set by the users. As soon as the cautions are received, the cell phone can browse the real-time in-vehicle images anytime and anywhere. The functional schemes of DASS are described as follows.

2.1 Active Real-Time Image-Based Lane Departure and Vehicle Detection Warning System for Both Front and Rear Views

With the platform-dependent optimizations of the memory and the enhanced direct memory access (EDMA) management, the complex algorithms that can perform real-time vehicle detection and lane departure warning for both front and rear views are implemented. LVWS can determine whether the vehicle is deviating from the road or is too close to other cars in the front and the rear directions, and generate the caution signals. In the different conditions, such as sunny, cloudy, rainy days and night, the information of lanes and the vehicles can be successfully obtained. The main reason for the vehicle accidents is the irregular driving behaviors, and the normal warning system can only produce sound or blinking lights which are not enough for protection. LVWS can transmit the warning message to the police department or the family people of the driver, and they can notify them before the tragedies. The whole flow is shown in Fig. 2.

2.2 H.264 Driving Status Recorder

If the drivers are in danger, the reasons that cause the accidents are the most important part. The driving status recorders are not popular nowadays, and they can only provide the data of throttle and the brake which are not able to reconstruct the situation. MSR can record the full-time driving status in H.264, which is suitable for a stand-alone system since its video quality and its compression ratio are very high, in the CF storage card, and the video recorded by MSR can help the police or the related departments for reference. The state chart of the system is illustrated in Fig. 3.

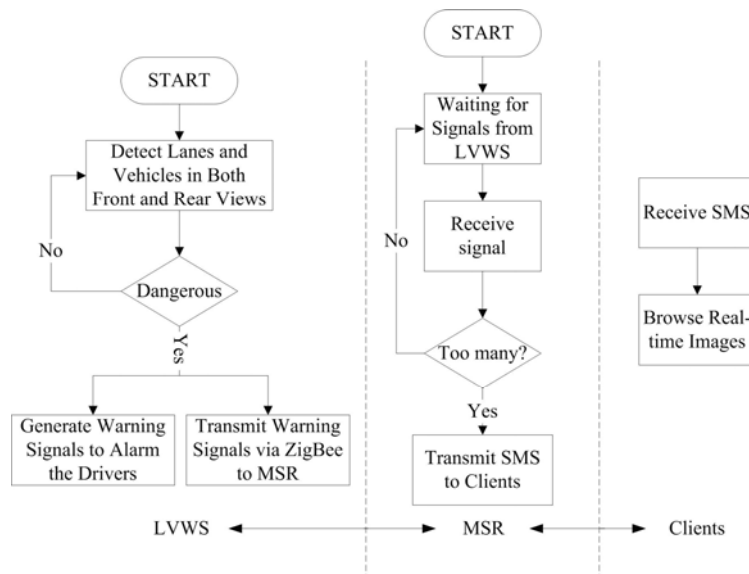

Fig. 2. The flowchart of the active real-time vehicle detection and lane departure warning system.

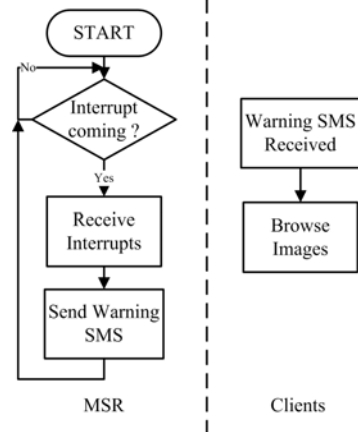
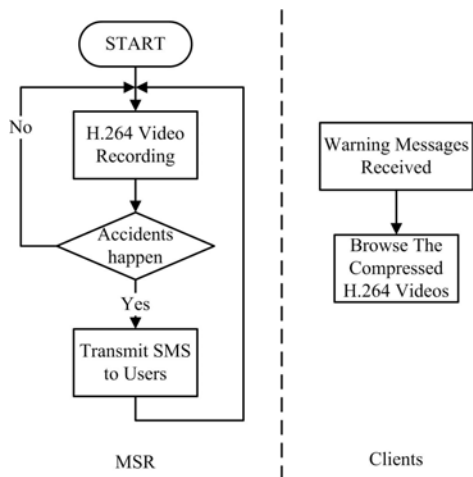

Fig. 3. The flowchart of the full-time recorder. Fig. 4. The flowchart of the mobile surveillance system.

2.3 Burglarproof with Mobile Surveillance

The recent vehicle surveillance systems, such as On Star [19] in USA and TOBE [20] in Taiwan, can provide the latest information of your car by short text messages. However, in the current applications, no matter the short message or the GPS navigation, both can not provide the intruders' pictures. The users can only know there is something happened in their vehicles, but they can not know what exactly the situation is. Maybe there really exists a thief or just a heavy truck goes by. Therefore, a burglarproof system with mobile surveillance and friendly user interface for mobile devices are developed to

clear the above drawbacks. It can access the Internet by 3.5G/3G so that the server can be installed in the vehicles, not restricted by the wired Internet environment. When the intruders try to steal users' vehicles, MSR will transmit the warning short messages to users' mobile phones. As soon as the users receive the cautions, they can browse the real-time images in the vehicle anytime and anywhere. In addition, the software in the mobile clients is very easy to use. The users simply press one button to browse the continuous pictures. Thus, it can supply the all service functions through 3.5G/3G communication to help the vehicle owner understanding their vehicle conditions, and the program flowchart is shown in Fig. 4.

3. THE SOFTWARE OF LVWS AND MSR

The functional schemes of DASS are described as follows. In this section, the relative algorithms which include the lane and vehicles detection of LVWS and H.264 video encoding algorithm in MSR are addressed. The system architectures of LVWS and MSR are shown in Figs. 5 and 6, respectively. Since the features of real-time notification the mobile surveillance require the network protocol stack, embedded Linux is chosen as the

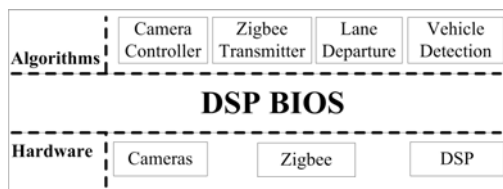

Fig. 5. The system architecture of LVWS.

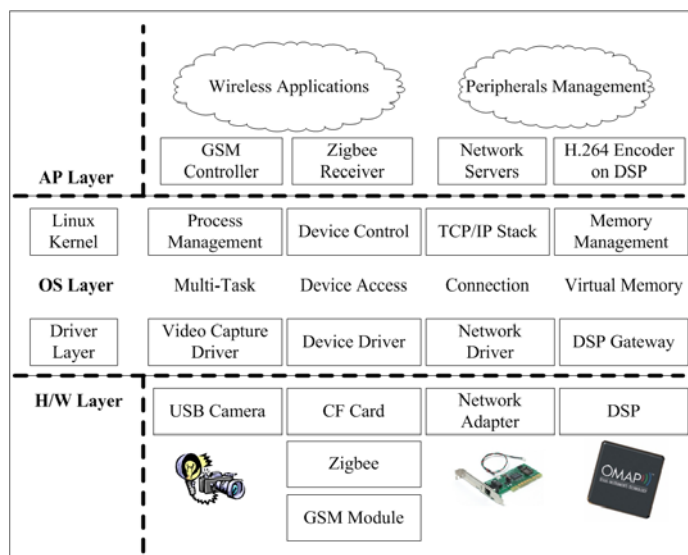

Fig. 6. The system architecture of MSR.

operating system (OS) in MSR. Moreover, the low computing power of the embedded systems has to be considered seriously. The algorithms have to be as simple as possible while maintaining the high detection accuracy.

3.1 Lane Detection Algorithm

Chapuis *et al.*, [21, 22] proposes an algorithm which composes the road detection model and the 3-D reconstruction model starting from image coordinates. The authors combine these two models [23] to perform a smart lane detection module. This parabolic polynomial module is applied to obtain the recognized lane markings such that curves can be estimated more accurately. Instead of heavy calculation due to the training phase in the preliminary recognition process, the lane tendency is primarily predicted by using the first-order Taylor polynomial to fast figure out the possible region of interest (ROI). Once the lane tendency is determined, the road model is updated in a recursive way after each lane marking detection. This module is also extended to a multi-model vision-based framework to perform multi-lane detection against road singularities [24]. In the proposed module, the projection relationship from global coordinates (x, y, z) to the image plane (u, v) is shown in Eqs. (1) and (2), where $e_u = f/du$ and $e_v = f/dv$ with the physical width and height of an image pixel, du and dv , respectively, f is the focal length and H is the height of camera.

$$u = e_u \frac{x}{y} \quad (1)$$

$$v = e_v \frac{z - H}{y} \quad (2)$$

The parabolic polynomial lane model is utilized to describe the lane trend in Eq. (3), where k , m and b are the coefficients of this model. Note that this model is illustrated in global coordinates. Since the image is projected from (x, y, z) space to (u, v) plane, Eq. (3) is adapted to Eq. (4) for the proposed algorithm by substituting Eqs. (1) and (2) into Eq. (3), where $z = m_\theta \cdot y$ and m_θ is the road inclination. This equation brings the lane marking information on image plane when the lane trend is available, *i.e.*, m and b coefficients are given.

$$x = k \cdot y^2 + m \cdot y + b \quad (3)$$

$$u = \frac{ke_u e_v H}{e_v m_\theta - v} + me_u + \frac{be_u}{He_v} (e_v m_\theta - v) \quad (4)$$

The proposed algorithm follows the prediction-verification-updating principle. For the lane trend prediction, three reasonable rules are assumed. The first one is $\frac{1}{2}(u_R + u_L) = u_M = e_u \frac{x_M}{y_M}$, where u is the abscissa on the image plane, x and y are the global coordinates and the M , R and L indexes mean the middle, right and left boundaries of the lane.

The second one is $(u_R - u_L) = e_u \frac{x_R - x_L}{y_M} = e_u \frac{W}{y_M}$, where W is the lane width in world space. In general cases, the left, middle and right sides of the lane are assumed in the same horizontal scan line on the image. Therefore, the last rule is $v_R = v_L = v_M = e_v \frac{z_M - H}{y_M}$, where v is the ordinate on the image plane. From these three assumptions, we have

$$x_M = \frac{u_M \cdot W}{u_R - u_L} \quad (5)$$

$$y_M = e_u \frac{W}{u_R - u_L} \quad (6)$$

$$z_M = H + \frac{v_M \cdot W}{u_R - u_L} \cdot \frac{e_u}{e_v}, \quad (7)$$

it yields

$$u_M (u_R - u_L) = ke_u^2 W + me_u (u_R - u_L) + \frac{b}{W} (u_R - u_L)^2 \quad (8)$$

for lane trend prediction. The least square approximation is applied for obtaining the coefficients k , m and b . The one has to be mentioned is that Eq. (8) works when W is given. The calculated k , m and b will assist in getting the lane marking coordinates by substituting them into Eq. (4). In the lane marking detection, the intensity of the lane markings are applied with its dark-light-dark (DLD) characteristic, as shown in Fig. 7 (a). The point M is located at the DLD transmission if the intensity of M , I_M , exceeds that of its left and right side neighbors by half of lane marking width on image plane, $MI/2$, as shown in Fig. 7 (b). The points L and R are defined if L and R own the maximum gradients in the $[M - MI/2, M)$ and $(M, M + MI/2]$ intervals, respectively, in Fig. 7 (c). Once L and R are picked, \overline{LR} is taken as lane marking in Fig. 7 (d) if $\overline{LR} > \overline{LR}_{th}$, where \overline{LR}_{th} is a predefined threshold. Note that R of the left hand \overline{LR} is chosen as the marking coordinate and L of the right hand \overline{LR} stands for the one.

The last step in the detection algorithm is the parameter updating. m_θ and W are the two parameters for the automatic online calibration.

The lane trend prediction plays a key role in this algorithm. Since we have $z = m_\theta \cdot y$, where $y = e_v \frac{H}{e_v \cdot m_\theta - v}$ and $z = e_v \frac{m_\theta \cdot H}{e_v \cdot m_\theta - v}$, Eq. (9) is obtained for parameter calibration, where $C_{zy0} = e_v \cdot m_\theta$ and $C_{zy1} = e_v H / e_u W$.

$$v_M = C_{zy0} - C_{zy1} \cdot \Delta u \quad (9)$$

The weighted least square method yields the coefficients C_{zy0} and C_{zy1} in Eq. (9) and afterward m_θ and W are available by the inverse calculation. The lateral offset, $O(y)$, is according to the coefficients in Eq. (3), k , m , and b , by Eq. (10), where y is set as the de-

sired distance ahead the vehicle. The warning signal will be generated when $O(y) \geq 0.25W$.

$$O(y) = k \cdot y^2 + m \cdot y + b \tag{10}$$

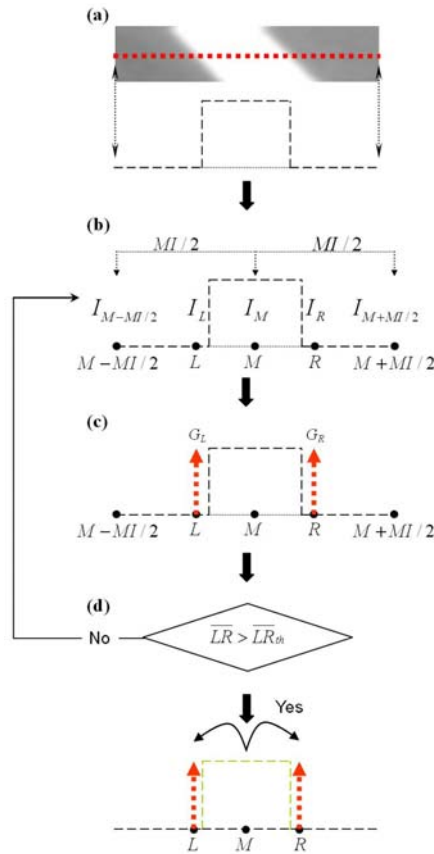

Fig. 7. Lane marking detection.



(a) Horizontal edged image.



(b) Vertical edged image.

Fig. 8. The sobel edged binary image.

3.2 Vehicle Detection Algorithm

Vehicle detection is combined with the lane detection [25, 31]. Sobel edge detection [30] is applied in the vertical and horizontal edge identification. Fig. 8 shows the binary images of horizontal and vertical edge, respectively ($Edge_h$ and $Edge_v$). Since the host lane area is acquired from the lane detection in A , the searching area for vehicle is limited in the host lane to reduce the computing burden, *i.e.*, the edge detection only be processed in the host lane area. In this area, three scan lines are assumed for vehicle detection in Fig. 9, where $B_1 = (A_1 + A_2)/2$, $C_1 = (A_1 + B_2)/2$ and $C_2 = (B_1 + A_2)/2$. The vehicle is searched with the continuous horizontal edge along B_1 , C_1 and C_2 from bottom to top. As shown in Fig. 10, this is an $Edge_h$ binary image. Once some $Edge_h$ appears on the scan line, the continuous $Edge_h$ will be checked to confirm if the vehicle exists. The reasonable width of this continuous $Edge_h$ is adjusted with the ordinate on the image plane. Referring to this $Edge_h$, a vehicle candidate block is assigned for the advanced identification. In this block, the tire contour for daytime and the light from taillight for nighttime are the features for the further detection of vehicle. Furthermore, the $Edge_v$ pair is a key feature for vehicle position identification. As shown in Fig. 11, the $Edge_v$ histogram in the candidate block gives two peaks which indicate the vehicle side boundaries.

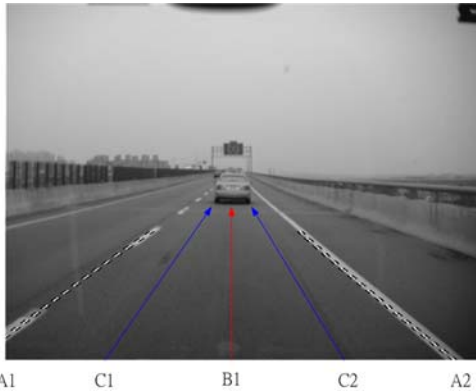

Fig. 9. The scan lines for vehicle detection.

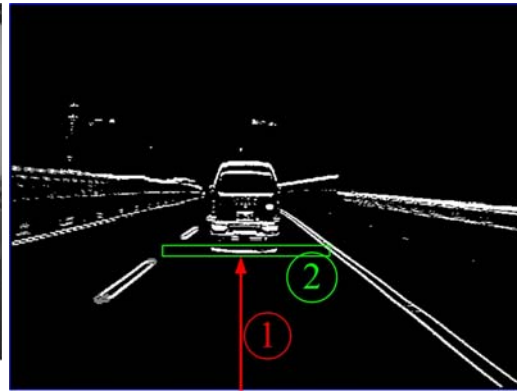

Fig. 10. Vehicle search processes.

The distance estimation between the preceding and the host vehicles by vision-based system has much error since the vehicle vibrations and the projection distortion. The road inclination, m_θ is given another description as the tilt angle of the camera, which exists when the vehicle vibrates even it has been calibrated to 0° tilt angle. In the presented lane detection algorithm, m_θ is calibrated automatic online, the more accuracy distance estimation is yielded by

$$y = e_v \frac{H}{e_v \cdot m_\theta - v}.$$

3.3 The Software Architecture of MSR

With the rich functionalities, the software architecture of MSR is illustrated in Fig. 6. The embedded OS is responsible for handling the schedule of the software and the control

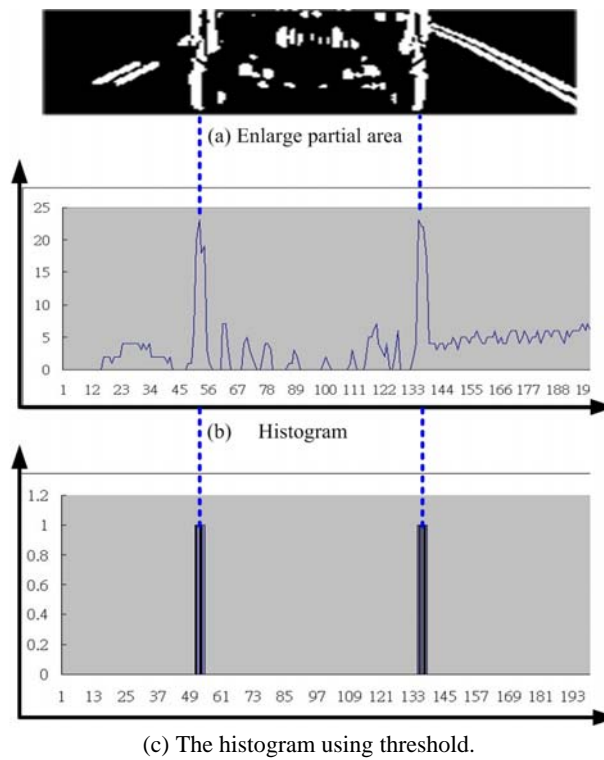

Fig. 11. The vertical edge histogram.

of the hardware. In Fig. 6, MSR can be separated into three layers, the application, the OS, and the hardware layers, and each layer has its dedicated works. The ZigBee receiver will acquire the data from LVWS, and MSR can process the data to distinguish whether the vehicles are safe or in danger. The 3.5G/3G module controller can send the warning short messages and connect to the Internet via 3.5G/3G to pass the images capture by the USB camera to users' mobile phones through the 3.5G/3G module. Furthermore, the H.264 video encoding algorithm is manipulated by DSP, and it acts as a device of ARM through the DSP Gateway. When ARM grabs a picture from the USB camera via the device driver, it will generate an interrupt to DSP to enable it for encoding. As soon as DSP starts to compress, ARM will capture the next image to reduce the time for data fetching, and perform the H.264 framework in pipeline. Moreover, the network servers can streaming out the bitstream on the fly, and can let the users download the files to reconstruct the driving status by the general Internet browsers easily.

4. THE OPTIMIZATION METHODS OF PLATFORM-DEPENDENT DESIGNS FOR DSPS

The algorithms developed on PC cannot be ported to the embedded systems directly due to the computing power and the limited memory. Therefore, the optimization meth-

ods in the flow and the memory usage of the programs should be modified based on the platform-dependent considerations. The main accelerator of the embedded systems is the direct memory access (DMA) unit which can share the loading of DSPs and can perform the parallel processing for moving the data. The DM642 and OMAP5912 platforms have 64 and 6 independent channels DMA, respectively, and the bandwidth of each one is up to 2.4 GB per second from the TI technical reports [26]. The enhanced DMA (EDMA) supported by TI provides the efficient and convenient usage, and its definitions and the operations are depicted in Fig. 12 [27]. Both the addresses of the source and the destination have to be set, and EDMA will move the data directly without the help of DSP. The memory reduction methods by using EDMA efficiently and optimizing the program for DASS are described below.

Address	QDMA channel options	
0x0200 0000	QDMA channel options	
0x0200 0004	QDMA channel source address	
0x0200 0008	1-D/2-D	Element count
0x0200 000C	QDMA channel destination address	

Fig. 12. The definitions of EDMA.

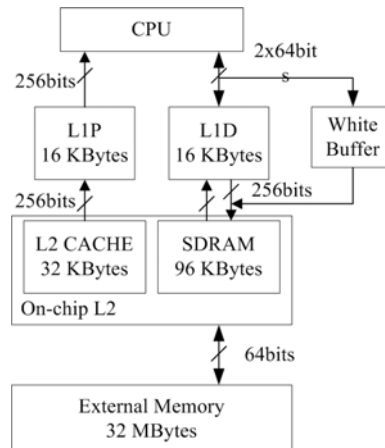

Fig. 13. Three-level hierarchy architecture.

4.1 Platform Dependent Optimization

The DSP BIOS is used to allocate the required resources [28], and the system performance can be greatly increased by accessing the high-speed small-size internal memory (IM) and the low-speed large-size external memory (EM) well. The bottleneck of the real-time image processing of DASS is the bandwidth of accessing the memory. Fig. 13 shows the three-level hierarchy architecture of DASS, and each block works at different operating frequencies. The fast cache memory in level 1 is separated into two parts, one is for the level 1 program, L1P, and the other is for caching the image data, L1D. Since L1D is too small to store the original image for processing, efficient data fetching algorithm is adopted in DASS to fully utilize the IM to increase the speed. L1P and L1D are much faster than EM, and through the EDMA operations, the waiting time of DSP can be reduced.

Therefore, a suitable memory allocation which can enormously increase the performance for DASS is proposed. The memory map of DASS is shown in Fig. 14, and the limited size of IM, 256 KB, can be used. However, the system also needs IM to run applications and store some statistic data, such as system buffers, vectors, heaps and stacks.

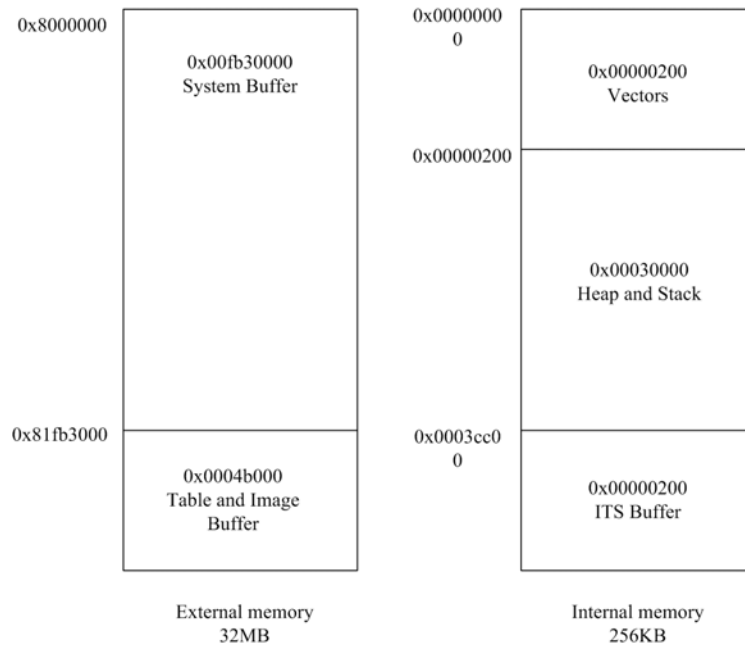

Fig. 14. Memory allocation.

Therefore, the algorithms should be modified to reduce its IM usage, so only two lines of the captured image are required after testing and scheduling. In DASS, the width of a frame is 352 pixels, so 704 bytes are necessary for cache usage. Furthermore, ping-pong buffer technology is adopted to increase the overall speed, and these buffers are allocated in a block of IM. Moreover, EM can be pre-defined by using DSP/BIOS at the beginning of the program, and can reduce the system overhead.

4.2 Program Optimization

The program optimization contains the design of the algorithm, which is described in section 3, and the coding style that should be adjusted to the specific compiler of DSP. The techniques which are applied in DASS are addressed in the following.

4.2.1 Intrinsic syntax

Some operations are easy to be implemented in the C language, but it needs more cycles than using the assembly one. Fortunately, the compiler support a large number of inline functions which combines the convenience of the C language and the performance of the assembly one. For example, the intrinsic operator “_abs”, and “_divf” can be used to calculate the absolute value, and the float division, respectively, which the C6000 compiler provides to optimize the programs [29].

4.2.2 Appropriate data type

Based on the very long instruction words (VLIW) properties provided by TI, some redundant data memory could be reduced. In the overall algorithm flow, the upper and lower bound of the variables can be estimated, and appropriate declarations of the data type can be defined. Using the skill has two advantages, one is to decrease the memory usage, and the other is to make the instructions operate fully based on VLIW characteristics to increase the performance.

5. THE IMPLEMENTATION RESULTS

All functionalities and the system of DASS are successfully implemented, and they are tested by the real road environments in Taiwan. DASS is well installed in the vehicle, which is called "TAIWAN iTS-1" in Fig. 15, and the cameras of LVWS are placed in front and back of the vehicle, shown in Fig. 16. On the other hand, the USB camera of MSR is also planted in the right-front of the vehicle in order to capture the images of the driving status, and the position is illustrated in Fig. 17. The testing results include series of the conditions such as general cases, rainy days, complicated roads, and the interference of the windshield wipers and the lights. The detail specification of DASS is illustrated in Table 1, and the experimental results of each function are described below.

Table 1. The specification of DASS.

Functions	Items	Results	
Lane Departure and Vehicle Detection	Platform	TI DM642 @600 MHz	
	Cameras	Ch-1 Front View	Ch-2 Rear View
	Weathers	Sunny, Cloudy, Rainy and Night	
	Road Types	Highways and Urban Roads	
	Processing Speed	30 frames/second	30 frames/second
	Image Size	CIF	CIF
H.264 Encoder	Platform	TI OMAP 5912 @192 MHz	
	Camera	USB Camera	
	Encode Speed	8 frames/second	
	Compression Ratio	80 in Average Record 313.83 Hours for One 8GB CF Card	
	Image Size	QCIF	
	Quality	40dB in Average	
	Profile	H.264 Baseline Profile	
ZigBee Communications	Distance	20 Meters in Real Tests	
	Baudrate	9600 bits/second	
	Power	Less than 0.15W	



Fig. 15. TAIWAN iTS-1.



Fig. 17. The USB camera mounted behind the right front windshield.



(a)



(b)

Fig. 16. The monochromatic CCD mounted behind the (a) front (b) rear windshield.

5.1 Lane Departure and Vehicle Detection Algorithms

The lane departure and the vehicle detection algorithms are verified, and the results of lane marks and the vehicles in both front and rear direction, which are shown in Figs. 18 to 21, are located simultaneously. In Figs. 18 to 21, the results in general cases, rainy days, complex roads, curved roads, and night are depicted, and LVWS can successfully manipulate the desired outcomes at 30 FPS. In average, the correctness ratio of the vehicle detection is tested, and it is about 94%, 90 % and 88% in the distance of 30 meters, 40 meters and 50 meters, respectively. In locating the lane marks, it can be up to 99% in every condition. These statistics show the algorithms in LVWS are robust and suitable for the real world.

In our experiments, LVWS works well in a highest speed at 145km/h, but not limited. Since LVWS performs 30 FPS, a notification signal is generated in 33ms, *i.e.* the host vehicle is driven 40.27m under 145km/h. The detection ratio of our vision system is summarized in Table 2 for these various conditions. The detection ratios of lane-marking and vehicle detection are more than 99% and 94%, respectively. These results support that the system's functions can stand more practical circumstances.

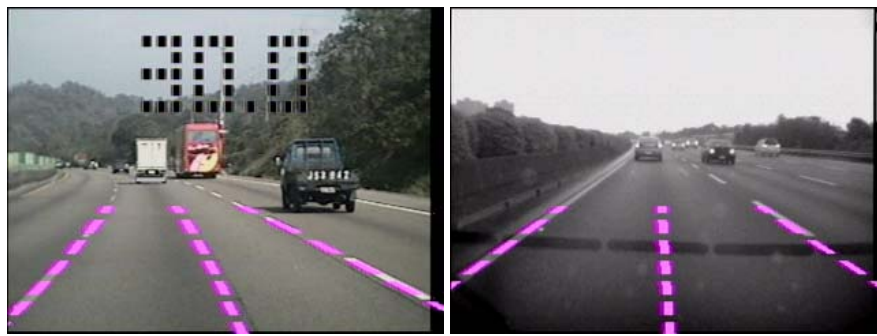

(a) General case. (b) Rainy day.
Fig. 18. Detection in the front view.

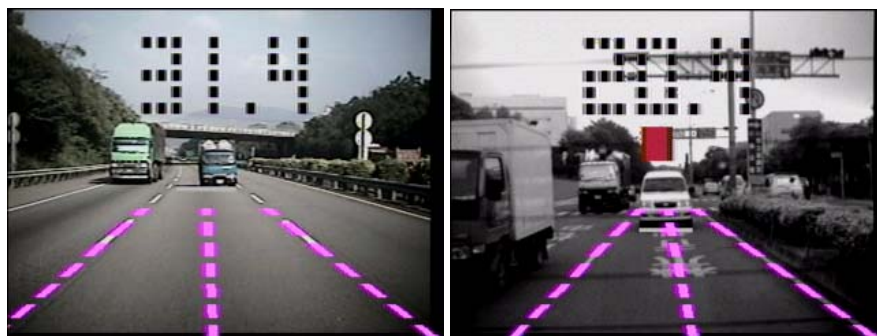

(a) General case. (b) Complex road.
Fig. 19. Detection in the rear view.



(a) Curved road. (b) Night.
Fig. 20. Detection in the front view.



(a) Interference of windshield wipers. (b) Interference of strong light in rainy days.
Fig. 21. Detection in the front view.

Table 2. Detection ratios under different conditions in highways.

Weather	Daytime (sunny & cloudy)	Rain	Nighttime	Total
Lane-Marking Detection				
Missed/Detected Frames	301/26340	263/6930	394/65571	958/98841
Detection Ratio	98.86%	96.20%	99.40%	99.03%
Vehicle Detection				
Missed/Detected Frames	31/1018	85/1038	59/1024	175/3080
Detection Ratio	97.04%	92.43%	94.55%	94.62%

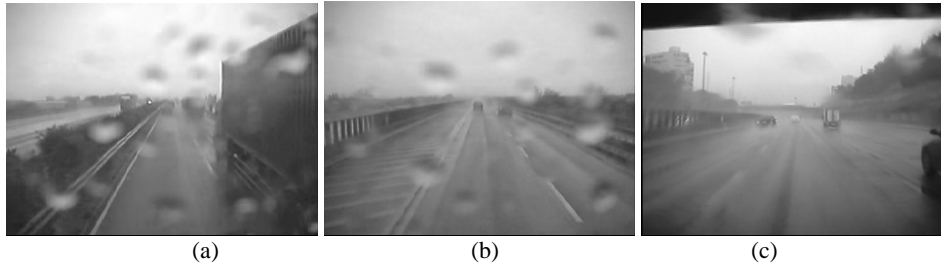

Fig. 22. The cases that LVWS confuses.

In some cases, shown in Fig. 22, LVWS will fail to detect the lane information. The side of the truck in Fig. 22 (a) confuses LVWS since the pixels similar to lane markings and their positions in the image are still within the permission range in our lane marking search model. Figs. 22 (b) and (c) show the heavy rain condition that lane markings cannot be identified by human eyes. In this case, LVWS is still in trouble.

5.2 Real-time Notification by the Cooperation with LVWS and MSR

When the drivers have dangerous behaviors, such as lane departure, LVWS will generate a warning signal to MSR, and the “Warning” text is displayed on the panel, which is shown in Fig. 23. The status of the turn signals of the vehicles is input to MSR to help the warning decisions. In DASS, when the vehicle is deviating for longer than 3 seconds without enable the turn signals, which indicates that the drivers are not going to change lane or pass the preceding car, MSR will send the caution short message to the mobile phones which set by the users. In TAIWAN *i*TS-1, the distance between two Zig-Bee modules, which connect to LVWS and MSR, is 200 cm, and the transmitting route is blocked by the passengers and the chairs. Because LVWS can detect the lane marks and the approaching vehicles with 30 FPS, the warning signal will be generated within 33 milliseconds. It takes less than 1 millisecond from transmitting it from LVWS to MSR, and the average error rate is 0.008%. When MSR acquires 80 warning signals within 3 seconds, it will automatically notify the users, and the message will be received within 3 seconds, which means that if the drivers are in danger, the notification will be produced in 6 seconds. The users, who need to know the exact situation of the drivers, can browse the real-time driving status to decide to call the police for help or not.

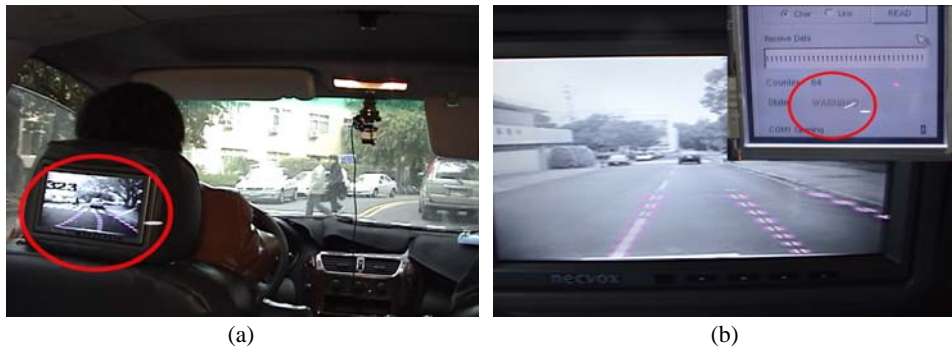

Fig. 23. (a) The real-time output in screen; (b) The warning message is shown in the OMAP5912 panel.



Fig. 24. (a) The real-time image is recorded by OMAP5912. User can review the image from (b) by Internet.

5.3 Full-time Driving Status Recorder

MSR begins to record the driving status as soon as the vehicle starts, and the encoded bitstream will be stored in the CF storage cards with the H.264 format. Not only the video but also the detection information from LVWS are taken down. If the terrible accidents happened, these files can be downloaded from the general web browser, such as the Internet explore (IE), Mozilla firefox, and Netscape, or directly read them in the CF cards. The drivers' face and body can reveal their condition, such as dozing or looking around, and the data from LVWS can help the police to reconstruct the scenes. They can be played with the normal media player, and since the driving status does not contain lots of motion, the frame rate can up to 8 FPS in QCIF which is enough for reconstruct the original condition. Fig. 24 (a) shows the recording procedure during the vehicle is moving, and Fig. 24 (b) illustrates the compressed file played by the PC.

5.4 Mobile Surveillance System

When the vehicle is parked, the mobile surveillance system is activated. The users can know the circumstances of their properties anytime and everywhere. The Java program developed for mobile phones enables users to see real-time images through the

3.5G/3G protocol. Images are transmitted from MSR so that if something is sensed by the settle sensors, a short message is sent to the user to notify of an emergency. The Java applet on their mobile phone shows the real-time continuous QCIF images on the screen, and the result is shown in Fig. 25. However, the actual average bandwidth of 3.5G/3G is approximately 150K to 200K bits per second for the downloading data transmission rate. The QCIF JPEG image size is approximately 5K bytes so that the mobile phone can download the compressed image data from MSR and display the decoded JPEG image at 3 FPS. The processing time will be reduced if 3.5G/3G can gain a faster download speed.



Fig. 25. Mobile surveillance.

Table 3. The comparison between different systems.

Systems	Platforms	Frame size/ Frame rate	Road type	Vehicle detection	Mobile notification/ Vehicle surveillance	Status Recorder	Directions
DASS	DSP-based	352 × 240 / 30 FPS	Curved	Yes	Yes / QCIF @ 8 FPS	Yes	Front and rear
[15]	ARM-based	128 × 128 / 22 FPS	Straight only	No	No	No	Only front
[16]	DSP-based	320 × 240 / 16 FPS	Straight only	Yes	No	No	Only front
[17]	ASIC / power PC	640 × 480 / 30 FPS	Curved	Yes	No	No	Only front
[5]	PC-Based	X	X	Yes	No	No	Front and rear
[18]	PC-Based	X	X	No	No	Yes	X

5.5 Comparisons

Finally, the comparisons in functionalities between several different systems are shown in Table 3, and [15-17] can perform the lane departure algorithm. [17] has the

highest performance in LDWS, but the platform is too expensive. Furthermore, it can only detect the lane marks and the vehicles in the front view, and it lacks the mobile notification and surveillance functions. [15] and [16] are embedded processor-based systems which can greatly reduce the cost and the power consumption. However, the achievements in LDWS can be improved, since they can only locate the straight roads which are not robust enough to provide better safety assist. Besides, the approaching vehicles are also latent dangers. [5] can detect the vehicles in both front and rear directions, but it has to be installed in at least two cars to take effect. The operative distance of [5] is not far enough to meet the requirement of the real road environment at high driving speed. If the accidents happen, the vehicle status recorder can analyze the condition helpfully. [18] is equipped with a GPS receiver, and it can obtain vehicle's location, velocity, and orientation periodically. Nevertheless, it can not show the real causes of the casualty, and the GPS data can only update once per second which is not quick enough to track the instant status. DASS can manipulate the LDWS in 352×240 at 30 FPS in both front and rear directions, and it is a low-power and stable DSP-based system, which is very suitable for installing in the vehicles. It can adapt the conditions of curved roads, complex roads, rainy days, cloudy days, and night. Besides, DASS can film the situation to provide the facts to the users and the police officers, and they can easily and quickly understand the reasons. Furthermore, DASS provides an innovative function that no other system has – mobile notification and surveillance, which is useful for keeping the thieves away from users' properties. With these full-time safety assist features, DASS can establish a safer driving and parking environment.

6. CONCLUSIONS

In this paper, DASS with the lane and vehicle detection in both front and rear views of several conditions, such as general cases, rainy days, complex roads, curved roads, and nights, are implemented. Unlike other systems that can only provide single function, DASS also develops three main safety assist features, which are real-time notification by the cooperation with LVWS and MSR, full-time driving status recorder, and mobile surveillance system. DASS can protect the users and the vehicles whenever they are moving or not, and it has been successfully verified for hundreds of kilometers on Highway No. 3 and Expressway No. 68 in Taiwan.

7. ACKNOWLEDGEMENT

The authors would like to deeply thank the reviewers and the Associate Editor for the detailed comments, which considerable improve the presentation of this paper. The authors also thank Min-Wei Chung and Hsuan-Yi Hou for their support of this research and development as well.

REFERENCES

1. G. Jacobs, A. Aeron-Thomas, and A. Astrop, "Estimating global road fatalities,"

- Technical Report TRL 445, Transport Research Laboratory, Australian National University, 1999.
2. D. Royal, "Volume I — Finding report; national survey on distracted and driving attitudes and behaviors, 2002," Technical Report DOT HS 809 566, The Group Organization, Washington, D.C., 2003.
 3. J. Hagen, "Road safety crisis," UN Chronicle online edition, 2004, http://www.un.org/Pubs/chronicle/2004/webArticles/012204_road_safety.asp.
 4. W. S. Wijesoma, K. R. S. Kodagoda, and A. P. Balasuriya, "Road-boundary detection and tracking using ladar sensing," *IEEE Transactions on Robotics and Automation*, Vol. 20, 2004, pp. 456-464.
 5. S. T. Sheu, J. S. Wu, C. H. Huang, Y. C. Cheng, and L. W. Chen, "DDAS: Distance and direction awareness system for intelligent vehicles," *Journal of Information Science and Engineering*, Vol. 23, 2007, pp. 709-722.
 6. A. Kircher, M. Uddman, and J. Sandin, "Vehicle control and drowsiness," Technical Report VTI-922A, Swedish National Road and Transport Research Institute, Linköping, Sweden, 2002.
 7. T. Hayami, K. Matsunaga, K. Shidoji, and Y. Matsuki, "Detecting drowsiness while driving by measuring eye movement – A pilot study," in *Proceedings of IEEE Intelligent Vehicles Symposium*, 2002, pp. 156-161.
 8. L. M. Bergasa, J. Nuevo, M. A. Sotelo, R. Barea, and M. E. Lopez, "Real-time system for monitoring driver vigilance," *IEEE Transactions on Intelligent Transportation System*, Vol. 7, 2006, pp. 63-77.
 9. V. Kastrinaki, M. Zervakis, and K. Kalaitzakis, "A survey of video processing techniques for traffic applications," *Image and Vision Computing*, Vol. 21, 2003, pp. 359-381.
 10. J. W. Lee, C. D. Kee, and U. K. Yi, "A new approach for lane departure identification," in *Proceedings of IEEE Intelligent Vehicles Symposium*, 2003, pp. 100-105.
 11. S. Y. Kim and S. Y. Oh, "An adaptive lane departure warning system based on image processing and a fuzzy evolutionary technique," in *Proceedings of IEEE Intelligent Vehicles Symposium*, 2003, pp. 361-365.
 12. K. Weiss, N. Kaempchen, and A. Kirchner, "Multi-model tracking for the detection of lane change maneuvers," in *Proceedings of IEEE Intelligent Vehicles Symposium*, 2004, pp. 937-942.
 13. C. R. Jung and C. R. Kelber, "A lane departure warning system based on a linear-parabolic lane model," in *Proceedings of IEEE Intelligent Vehicles Symposium*, 2004, pp. 891-895.
 14. J. Kaszubiak, M. Tornow, R. W. Kuhn, B. Michaelis, and C. Knoeppel, "Real-time vehicle and lane detection with embedded hardware," in *Proceedings of IEEE Intelligent Vehicles Symposium*, 2005, pp. 619-624.
 15. P. Y. Hsiao and C. W. Yeh, "A portable real-time lane departure warning system based on embedded calculating technique," in *Proceedings of IEEE Vehicular Technology Conference*, 2006, pp. 2982-2986.
 16. C. H. Yeh and Y. H. Chen, "Development of vision-based lane and vehicle detecting systems via the implementation with a dual-core DPS," in *Proceedings of IEEE Intelligent Vehicles Symposium*, 2006, pp. 17-20.
 17. <http://www.mobileye.com/asp4.shtml>.

18. H. C. Yeh, S. Y. Chang, T. S. Chu, C. W. Chen, and C. S. Shih, "Vehicle information systems integration framework," *Journal of Information Science and Engineering*, Vol. 23, 2007, pp. 681-695.
19. <http://www.onstar.com>.
20. <http://www.tobe.com.tw>.
21. R. Chapuis, J. Gallice, F. Jurie, and J. Alizon, "Real time road mark following," *Signal Processing*, Vol. 24, 1991, pp. 331-343.
22. R. Chapuis, R. Aufrere, and F. Chausse, "Accurate road following and reconstruction by computer vision," *IEEE Transactions on Intelligent Transportation Systems*, Vol. 3, 2002, pp. 261-270.
23. B. F. Wu, C. J. Chen, C. C. Chiu, and T. C. Lai, "A real-time robust lane detection approach for autonomous vehicle environment," in *Proceedings of the 6th IASTED International Conference on Signal and Image Processing*, 2004, pp. 518-523.
24. R. Labayrade, J. Douret, and D. Aubert, "A multi-model lane detector that handles road singularities," in *IEEE Proceedings of Intelligent Transportation Systems*, 2006, pp. 1143-1148.
25. B. F. Wu, C. J. Chen, C. C. Kao, C. W. Chang, and S. T. Chiu, "Embedded weather adaptive lane and vehicle detection system," in *Proceedings of IEEE International Symposium on Industrial Electronics*, 2008, pp. 1255-1260.
26. TMS320C6000 DSP Enhanced Direct Memory Access (EDMA) Controller Reference Guide (SPRU234-March 2005), <http://focus.ti.com/lit/ug/spru234b/spru234b.pdf>.
27. TMS320C64x DSP Two-Level Internal Memory Reference Guide (SPRU610-Aug. 2004).
28. TMS320 DSP-BIOS User's Guide (SPRU303B-May 2000), <http://focus.ti.com/lit/ug/ug/spru423b/spru303b.pdf>.
29. TMS320C6000 DSP Optimizing Compiler Reference Guide (SPRU187L-May 2004).
30. R. C. Gonzalez and R. E. Woods, "Image segmentation," *Digital Image Processing*, 2nd ed., Prentice Hall, Inc., New Jersey, 2002, pp. 578-579.
31. B. F. Wu, Y. H. Chen, H. Y. Peng, and C. J. Chen, "A real-time vision-based safety assist system," in *Proceedings of IEEE International Conference on Systems, Man and Cybernetics*, 2008, pp. 2994-2999.



Chao-Jung Chen (陳昭榮) was born in Taoyuan, Taiwan, R.O.C., in 1977. He received his B.S. and M.S. degree in the Institute of Mechanical Engineering from Huafan University, Taiwan, in 1999 and 2001, respectively, and the Ph.D. degree in Electrical and Control Engineering from the National Chiao Tung University (NCTU), Hsinchu, in 2006. He is currently a Research Assistant Professor in the Department of Electrical and Control Engineering, NCTU. His research interest is real-time image processing in intelligent transportation systems.



Hsin-Yuan Peng (彭信元) was born in Taitung, Taiwan in 1980. He received the B.S. degree in Electrical and Control Engineering from National Chiao Tung University, Hsinchu, Taiwan, in 2002. He is currently working towards the Ph.D. degree in the same institute. He received the First Prize Award of TI China-Taiwan DSP Design Contest in 2006, and the Silver Award of Technology Innovation Competition sponsored by the Advantech Foundation in 2003. His research interests include video processing, and embedded system design.



Bing-Fei Wu (吳炳飛) was born in Taipei, Taiwan in 1959. He received the B.S. and M.S. degrees in Control Engineering from National Chiao Tung University (NCTU), Hsinchu, Taiwan, in 1981 and 1983, respectively, and the Ph.D. degree in Electrical Engineering from the University of Southern California, Los Angeles, in 1992. Since 1992, he has been with the Department of Electrical Engineering and Control Engineering, where he is currently a Professor. He has been involved in the research of Intelligent Transportation Systems for many years and leads a research team to develop the first Taiwan smart car, TAIWAN *i*TS-1, with autonomous driving and active safety system. His current research interests include vision-based vehicle driving safety, intelligent vehicle control, multimedia signal analysis, embedded systems and chip design. Prof. Wu founded and served as the Chair of the IEEE Systems, Man and Cybernetics Society Taipei Chapter in Taiwan, 2003. He received the Xerox-Fujitsu Academic Research Award in 2007; the Distinguished Engineering Professor Award from Chinese Institute of Engineers in 2002; and the Outstanding Information Technology Elite Award from Taiwan Government in 2003.



Ying-Han Chen (陳盈翰) received the B.S. and M.S. degrees in Electrical Engineering from National Central University in 2003 and 2006, respectively. He is currently working toward the Ph.D. degree in Electrical and Control Engineering at National Chiao Tung University, Hsinchu, Taiwan, R.O.C. His research interests include networking, navigation systems and embedded systems.