

National Chiao Tung University

Department of Civil Engineering

Master Thesis

**Discounted Cash Flows Time-Cost Trade-Off
Problem Optimization with Uncertainty Cost**

Graduate Student: Julianto

Advisor: Professor Ren-Jye Dzung

January, 2014

Discounted Cash Flows Time-Cost Trade-Off Problem Optimization with Uncertainty Cost

Graduate Student: Julianto

Advisor: Ren-Jye Dzung



A Thesis
Submitted to Department of Civil
Engineering College of Engineering
(工學院)
National Chiao Tung University
in partial Fulfillment of the
Requirements for the Degree of

Master

in

Civil Engineering

January, 2014

Hsinchu, Taiwan, Republic of China

TABLE OF CONTENTS

TABLE OF CONTENTS	ii
LIST OF TABLES	iv
LIST OF FIGURES.....	v
ABSTRACT	vii
ACKNOWLEDGEMENT	ix
CHAPTER 1 INTRODUCTION	1
1.1 Background and Motivation	1
1.2 Problem Statements.....	2
1.3 Research Objectives.....	2
1.4 Research Scope and Limitation	2
1.5 Methodology	3
1.6 Thesis outlines	3
CHAPTER 2 LITERATURE REVIEW	5
2.1 TCTO problems and existing solving techniques.....	5
2.2 Genetic Algorithms (GAs).....	9
2.3 Discounted Cash Flows (DCFs).....	11
2.4 Uncertainty on Project Time-Cost Trade-Off (TCTO).....	12
CHAPTER 3 EXPERIMENTAL DESIGN	14
3.1 Case project example description.....	14
3.1.1 CPM Network and Crashing Cost.....	16
3.1.2 Interest rate.....	17
3.1.1 Probabilistic Parameters.....	18
3.2 Formulation of problem model	23
3.3 Solving TCTO with DCFs problem.....	29

3.4 Simulation using @Risk	33
CHAPTER 4 RESULTS AND ANALYSIS.....	37
4.1 TCTO with DFCs Result and Analysis.....	37
4.2.1 Optimization with simulation results analysis	39
4.2.2 Probabilistic Risk Assessment	47
CHAPTER 5 CONCLUSION.....	52
5.1 Conclusion	52
5.2 Recommendation for future research.....	53
REFERENCES	54
APPENDIX A: SIMULATION OUTPUT RESULT	55
APPENDIX B: OPTIMAL COST AND DURATION SIMULATION AT 5 TH AND 95 TH PERCENTILE LEVEL	77
APPENDIX C: BETAGENERAL DISTRIBUTION	81

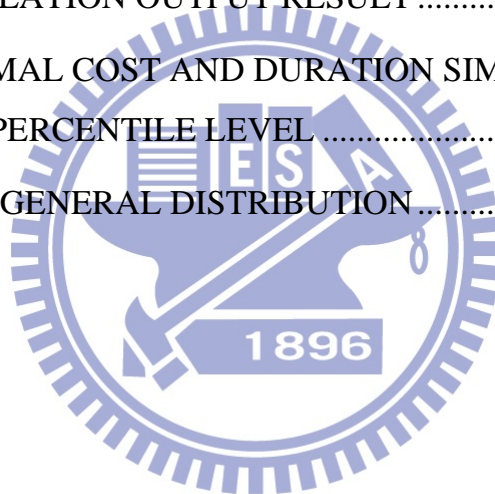

LIST OF TABLES

Table 3.1 Interest Rate Parameters	18
Table 3.2 Activities Utility Data of the Example Project	19
Table 3.3 Beta Probabilistic Parameters of Experiment Model Simulation	20
Table 3.4 Optimal duration solution	33
Table 3.5 Total minimum project cost with optimal duration solution	33
Table 4.1 Total cost from optimal solution duration at various interest rates	38
Table 4.2 Statistical simulation result of 65 weeks at 0.00% and 71 weeks at 5.25%	40
Table 4.3 Optimal solution of duration and total project cost at 5th and 95th percentile level	44
Table 4.4 Risk factor of construction project	51

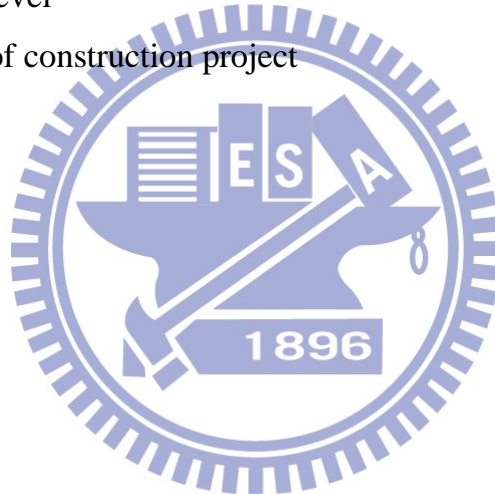

LIST OF FIGURES

Figure 1.1	Flowchart of research steps	4
Figure 2.1	Piece-wise Linear Activity Cost-Time Relation	6
Figure 2.2	Discrete Activity Cost-Time Relation	6
Figure 2.3	Convex Hull Activity Cost-Time Relation	7
Figure 2.4	The existing techniques in solving TCTO problems	8
Figure 2.5	Operation of genetic algorithms	10
Figure 2.6	Time value of money graph	12
Figure 3.1	Flowchart of experiment process	15
Figure 3.2	Precedence network of the example project	16
Figure 3.3	Simulation BetaGeneral Experiment I (52.55, 78.83, 20%, 130%)	21
Figure 3.4	Simulation BetaGeneral Experiment II (9.86, 69.04, 90%, 170%)	21
Figure 3.5	Simulation BetaGeneral Experiment III (5.01, 50.10, 90%, 200%)	22
Figure 3.6	Simulation BetaGeneral Experiment IV (8.33, 62.49, 80%, 250%)	22
Figure 3.7	BetaGeneral Experiment I, Experiment II, Experiment III, and Experiment IV distribution overlay graphs	23
Figure 3.8	Contractor's Expenses and Owner's Payments	23
Figure 3.9	Excel Spreadsheet for TCTO with DCFs	30
Figure 3.10	Cost DCFs Formula in cell H9	30
Figure 3.11	Excel spreadsheet for crashing cost	31
Figure 3.12	Excel spreadsheet for crash problem, 70-day solution with 0% interest rate	32
Figure 3.13	Evolver model dialog box	34
Figure 3.14	@Risk BetaGeneral Experiment I (52.55, 78.83, 80%, 130%) spreadsheets (1)	35
Figure 3.15	@Risk BetaGeneral Experiment I (52.55, 78.83, 80%, 130%) spreadsheets (2)	36
Figure 4.1	Total cost solutions for DCFs case with $r = 0.00\sim 8.5\%$	38
Figure 4.2	Total cost solutions for DCFs case with $r = 0.00\sim 15.00\%$	40

Figure 4.3 The simulation results Time-Cost box-plot chart for Experiment I betageneral (52.55, 78.83, 80%, 130%) at $r = 0\%$	41
Figure 4.4 The simulation results Time-Cost box-plot chart for Experiment I betageneral (52.55, 78.83, 80%, 130%) at $r = 5.25\%$	41
Figure 4.5 The simulation results Time-Cost curve betageneral Experiment I at $r = 0\%$ and $r = 5.25\%$	42
Figure 4.6 The simulation results Time-Cost curve betageneral Experiment II with $r = 5.25\%$	43
Figure 4.7 Cost-Time-Interest rate graphic relation for BetaGeneral Experiment I (52.55, 78.83, 80%, 130%)	44
Figure 4.8 Cost-Time-Interest rate graphic relation for BetaGeneral Experiment II (9.86, 69.04, 90%, 170%)	45
Figure 4.9 Cost-Time-Interest rate graphic relation for BetaGeneral Experiment III (5.01, 50.10, 90%, 200%)	45
Figure 4.10 Cost-Time-Interest rate graphic relation for BetaGeneral Experiment IV (8.33, 62.49, 80%, 250%)	46
Figure 4.11 Probability density function of total project cost Experiment I at duration 65 weeks ($r = 0.00\%$) and duration 71 weeks($r = 5.25\%$)	48
Figure 4.12 Cumulative distribution function of total project cost Experiment I at duration 65 weeks at $r = 0.00\%$	49
Figure 4.13 Cumulative distribution function of total project cost Experiment I at duration 71 weeks at $r = 5.25\%$	49

Discounted Cash Flows Time-Cost Trade-Off Problem Optimization with Uncertainty Cost

Graduate Student: Julianto

Advisor: Professor Ren-Jye Dzung

ABSTRACT

Optimization problems in time-cost trade-off (TCTO) analysis of construction management have been traditionally solved by two distinctive approaches: heuristic methods and optimization techniques. Although heuristic methods can handle large-size projects, they do not guarantee optimal solutions. Recently, artificial intelligence (AI) techniques such as genetic algorithms (GAs), ant colony optimization (ACO), and particle swarm optimization (PSO) have been introduced to overcome the problems associated with (1) large number of variables and constraints; (2) non linearity of time-cost functions; and (3) multi-objective optimization.

Traditional time-cost trade-off (TCTO) analysis of construction management assumes the constant value of activities' cost along the project time span. In fact, the value of money decreases with time or in other words, disregard time value of money. Therefore, discounted cash flows should be considered when solving TCTO optimization problems. Furthermore, in reality, due to different uncertainty, the actual cost of each option is also not known by the manager in advance as a risk. Hence, the total cost of the project may significantly because of these uncertainty. Unfortunately, traditional TCTO analysis also disregards this factor.

This study tries to incorporate time value of money and uncertainty into TCTO analysis. Details of model formulation are illustrated by an example project. The model has the following features: (1) optimum solution is guaranteed; (2) precise discrete activity time-cost relationship is used; (3) time value of money is taken into consideration; and (4) uncertainty in the project also are involved. The results show that inclusion of discounted cash flow results in distinct optimal project duration. Nevertheless, through the Monte Carlo simulation, which is in order to involve uncertainty, this proposed model also lead to distinct optimal duration at the certain percentile level. The proposed model for this study can help the practitioners in

considering time value of money and uncertainty cost, in order to make the best time-cost decision and to identify risks involved.

Keyword: time-cost trade-off; Optimization; discounted cash flow; uncertainty; simulation



ACKNOWLEDGEMENT

First of all, I would like to express my deeply sincere gratitude and grateful to my supervisor, Professor Ren-Jye Dzung for his valuable guidance, encouragement, patience during all stages of the study process. His guidance helped me in all the time of research and writing of this thesis. I could not have imagined having a better advisor and mentor for my master study. I have learnt a lot from him not only specialist knowledge but also skills in life.

Finally, I would like to give my special appreciation to my family, my friends, and all my classmates for their sharing, and great support throughout the study. They are great motivations for me to accomplish this research.



Julianto
Hsinchu, 2013

CHAPTER 1

INTRODUCTION

Chapter 1 describes the background motivation of this study discounted cash flow Time-Cost Trade-Off problem optimization with uncertainty cost. It explains the problem statement and shows the research objectives and scope of this study. Moreover, some points that are used to scope and limit this study are showed too. It also provides the methodology and the main steps which should be done to in this study.

1.1 Background and Motivation

The time and cost parameters of a construction project have been identified as major factors of the decision making process. In critical-path method (CPM), generally, the objective is to establish a minimum project cost with a reasonable time schedule based on realistic assumptions. The primary impact of project timing is money and project time is thus an equally essential factor. Since cost can be expressed as a function of time, it is possible to determine the project time-cost trade-off (TCTO) curve which provides the minimum possible cost of completing the project in its feasible time range. A TCTO analysis is essential to solve two classes of practical problems: (1) to find the shortest project duration without exceeding a given budget (a budget problem) and (2) to minimize the total cost while meeting a specific deadline (a deadline problem).

However, most of the existing techniques for solving TCTO problem do not consider a time value of money. It is implicitly assumed that value of money is constant whatever the project time span is. Costs of activities are summed up to form the project direct cost although activities are executed at different points of times according to their scheduled start and finish times. Since money has a time value, the time at which costs are incurred should be taken into consideration. For projects spans over than one year, it is more beneficial to consider time value of money. Many economical measurements

can be used; the most commonly used one is the net present value.

Meanwhile, construction schedules are also affected by many uncertainty such as weather, productivity, design, scope, site conditions, soils properties, material delivery time, and equipment efficiency. All risks in a construction project might be schedule risks because they are directly or indirectly related to the schedule. Moreover, all activities can be critical due to uncertainty, even those that are not critical according to deterministic CPM. Therefore, it is important to involve a more accurate methodology to predict the construction cost and schedule of a project, and meanwhile recognize the probabilistic technique for solving TCTO problem. Hence, it would not be possible to reliably determine the project cost and schedule, with a sufficient degree of uncertainty, to confidently minimize risk.

1.2 Problem Statements

The problem statements of this thesis are as follows:

1. How does Discounted Cash Flows (DCF) influence in solving Time-Cost Trade-Off (TCTO) problem?
2. How does the probabilistic cost influence decision making for solving TCTO problem with DCFs?

1.3 Research Objectives

The research objectives of this thesis are as follows:

1. To show how DCFs influences TCTO problem;
2. To show the influence of probabilistic cost in scheduling through simulation and its decision making for solving TCTO problem with DCFs.

1.4 Research Scope and Limitation

The scope of the research is as follows:

1. This study uses Evolver to solve TCTO problem and @Risk by Palisade Corporation as Monte Carlo Simulation software;

2. This study does not involve inflation rate factor for time value of money consideration.
3. This study aims to compare the probabilistic TCTO problem with a deterministic one under the consideration of DCF. In practice, the DCF is considered only for a project with a duration of multiple years. However, the duration of the deterministic case available from the reviewed literature in this study is approximately only 1.5 years. Nevertheless, this study still considered DCF for the analysis even it seems unnecessary. It is expected that longer project will enlarge the effect discussed later in this study.

1.5 Methodology

Based on the above, TCTO analysis approach model capable of involving the time value of money and uncertainty of project cost activities is developed from this research.

To do so, interest rate data as the time value of money parameter and project example data will be determined first. Next, the case problem example and its parameter will be modeled in the excel spreadsheet. Additionally, evolver is used to solve ordinary TCTO problem to obtain the optimal duration of project example. Moreover, the probabilistic distributions parameters are adjusted into Monte Carlo simulation using @risk by palisade risk analysis software. Finally, the result obtained from the simulation process can be analyzed and illustrated using graph. The time-cost-interest relation result can be compared using the different degree of uncertainty. Figure 1.1 shows the research process flowchart.

1.6 Thesis outlines

This thesis consists of five chapters are as follows:

Chapter 1 Introduction: background and motivation, problem statements, research objectives, research scope and limitation, methodology, thesis outline.

Chapter 2 Literature review: The existing techniques in solving Time-Cost Trade-Off (TCTO) problem, Genetic Algorithms (Gas), Discounted Cash Flows (DCF), uncertainty on project Time-Cost

Trade-Off (TCTO).

Chapter 3 Experimental design: Case problem example description, problem formulation, implementation of case problem into excel, asses DCFs and simulation with probabilistic cost parameters.

Chapter 4 Result and Analysis: Result and analysis of TCTO with DCFs, TCTO with DCFs in simulation, and probability risk assessment.

Chapter 5 Conclusion and recommendation: contributions and effects of involving DCFs in TCTO problem and probabilistic simulation.

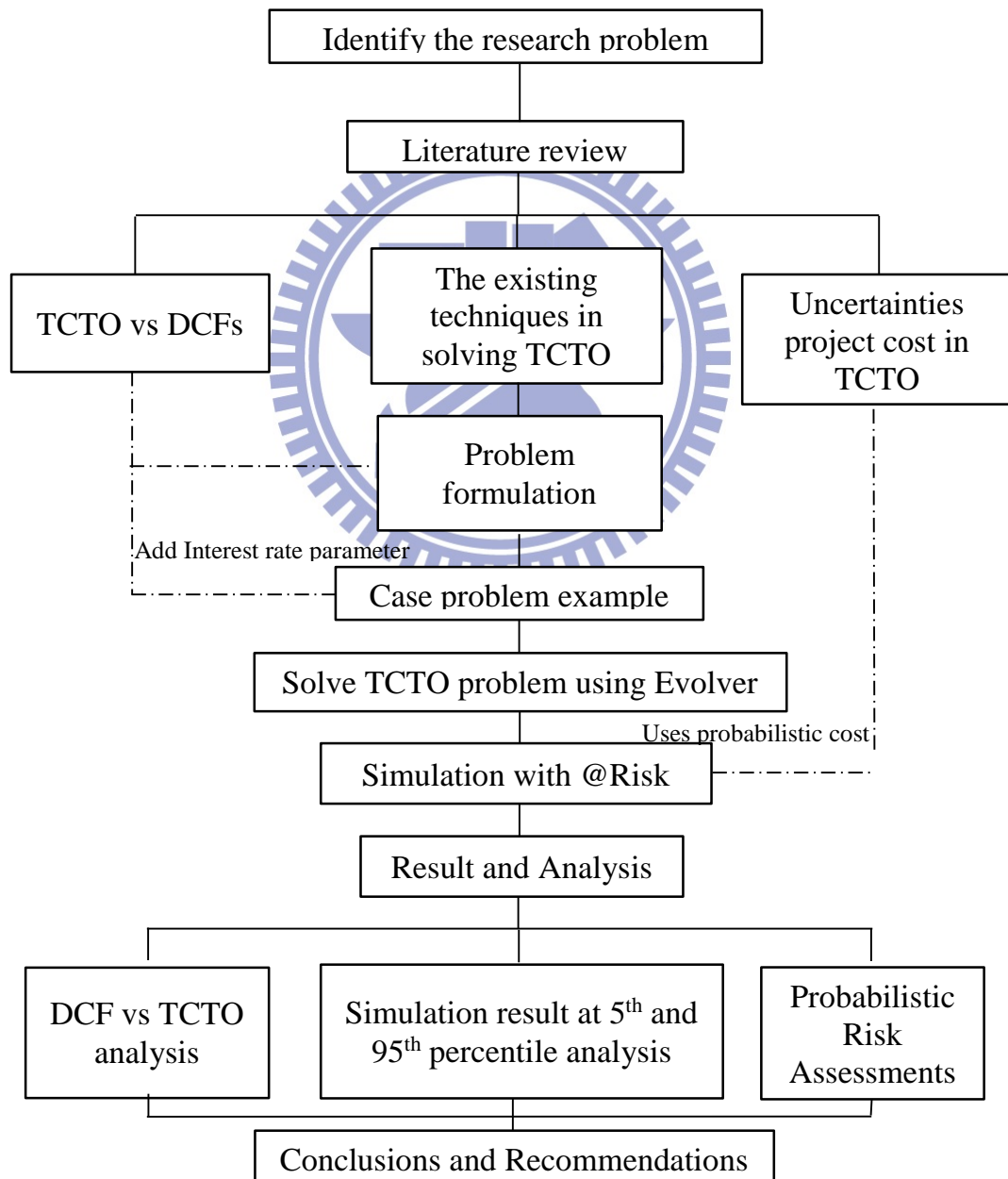

Figure 1.1 Flowchart of research steps

CHAPTER 2

LITERATURE REVIEW

This chapter presents the related past study of TCTO problem. The development of TCTO problems will be examined in this part. Since this study used Evolver that involved Genetic Algorithms (GAs) to obtain optimal duration, the previous studies which solved TCTO problem using GAs are also reviewed. Moreover the related studies of discounted cash flows (DCF) in TCTO, and uncertainty in a project will also be reviewed.

2.1 TCTO problems and existing solving techniques

In developing project time-cost curve, the scheduler should rely on realistic assumptions. Many forms of activity time-cost relationship have been assumed. They include linear, nonlinear, piecewise linear (Figure 2.1), and discrete point (Figure 2.2) or even convex hull (Figure 2.3) relationships. The normal and crash points are the two extremes of the time-cost function. The points between these two limits show the costs for the various feasible durations in which an activity can be performed. The detailed time and cost data of an activity obtained from construction estimate are usually referred to as utility data.

The function that may relate time and cost of construction activities is of great importance because the type of optimization technique depends mainly on that relationship (Tareghian and Taheri 2006). Most of existing time-cost optimization methods assume linear activity time-cost relationship in order to control computational effort and cost.

Many writers argued that the discrete time-cost relationship, Figure 2.2, is the precise one that suits construction activities (Ammar 2005). In practice, there is only limited number of ways to accelerate an activity, and thus only a finite number of discrete points can be defined. From the practical point of

view, the number of discrete points is finite and usually ranges from one to four (Eldosouky et al. 1991). Consequently, the number of variables required for the developed model is manageable even for large size projects. The discrete time-cost function will be adopted in the present analysis.

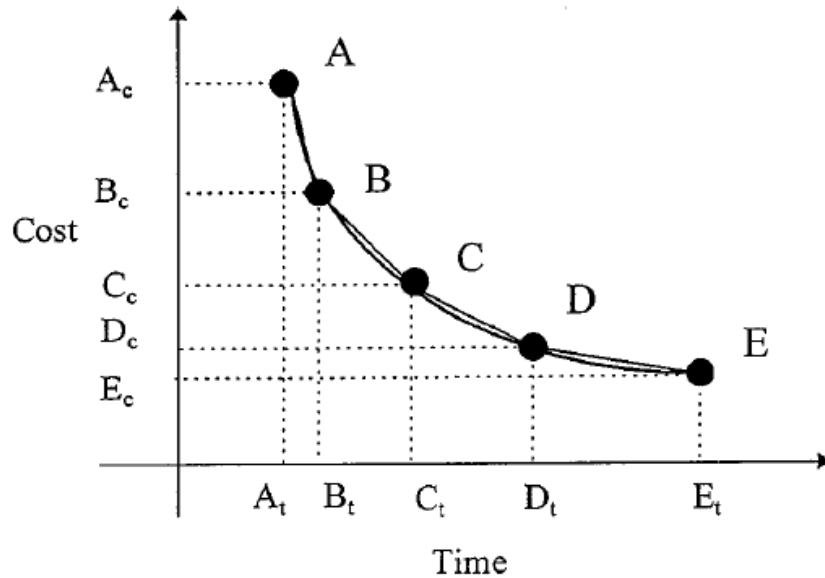

Figure 2.1 Piece-wise Linear Activity Cost-Time Relation (Liu and Burns, 1995)

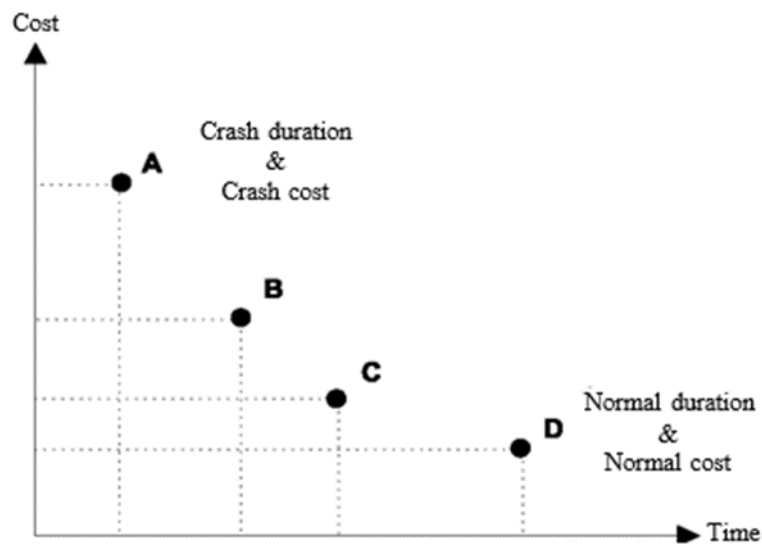

Figure 2.2 Discrete Activity Cost-Time Relation (Liu and Burns, 1995)

A mathematical optimization model for solving TCTO problem is presented. The model is formulated in the form of nonlinear programming that produces optimal solutions. The proposed model minimizes project direct cost considering time value of money. Precise discrete activity time-cost function

is used. The most common logical relationship; finish to start, is adopted. (Ammar 2010)

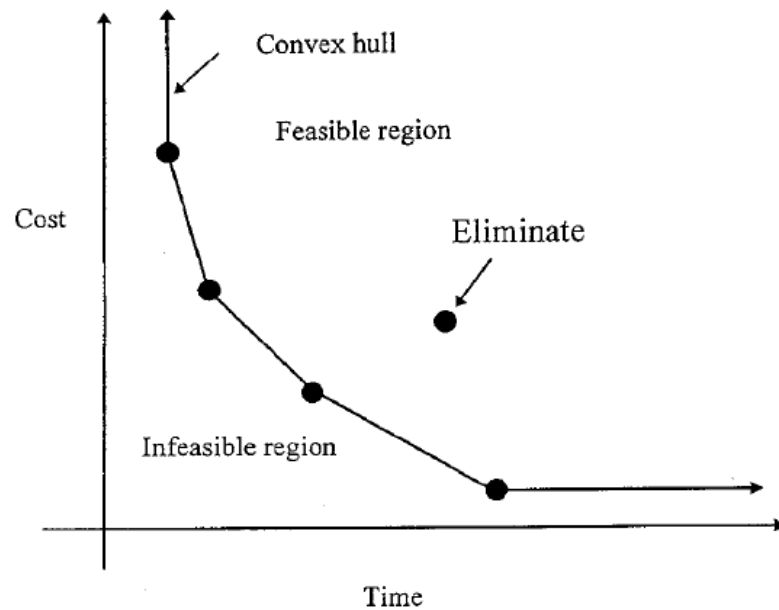

Figure 2.3 Convex Hull Activity Cost-Time Relation (Liu and Burns, 1995)

The time-cost trade-off problem for construction project scheduling has been investigated since the 1960s. Existing solutions can be classified into two categories, the heuristic and the mathematical approaches. Examples of heuristic approaches include Fondahl's method (Fondahl 1961), Prager's structural model (Prager 1963), Siemens's effective cost slope model (Siemens 1971), and Moselhi's structural stiffness method (Moselhi 1993). These heuristic methods provide fairly good solutions, even though they may not be optimal (Liu and Burns, 1995). Most heuristic methods, however, assume only linear time-cost relationships within activities. In addition, the solutions obtained by heuristic methods do not provide the range of possible solutions, making it difficult to experiment with different scenarios for what-if analyses. Heuristic approaches provide good solutions, but do not guarantee optimal solutions.

Mathematical approaches provide better solutions; however, the process of formulating the objective function and constraints is complex and prone to errors (Liu and Burns, 1995). Recently, artificial intelligence (AI) techniques such as genetic algorithms (GAs), ant colony optimization (ACO), and particle

swarm optimization (PSO) are introduced to overcome the problems associated with (1) large number of variables and constraints; (2) nonlinearity of time-cost functions; and (3) multi-objective optimization (Aladini, Afshar and Kalhor 2011). Meta-heuristic and evolutionary algorithms have shown relatively higher efficiency in handling these problems. Although they do not necessarily guarantee the global optimal solutions, their ability to search the solutions space intelligently, rather than completely, makes them capable of producing relatively good solutions to large-sized problems. Among them algorithms, the genetic algorithms (GAs) and ant colony algorithm (ACO) have received more attention. Figure 2.4 shows the approach to solve TCTO problem that can be categorized into three major approaches.

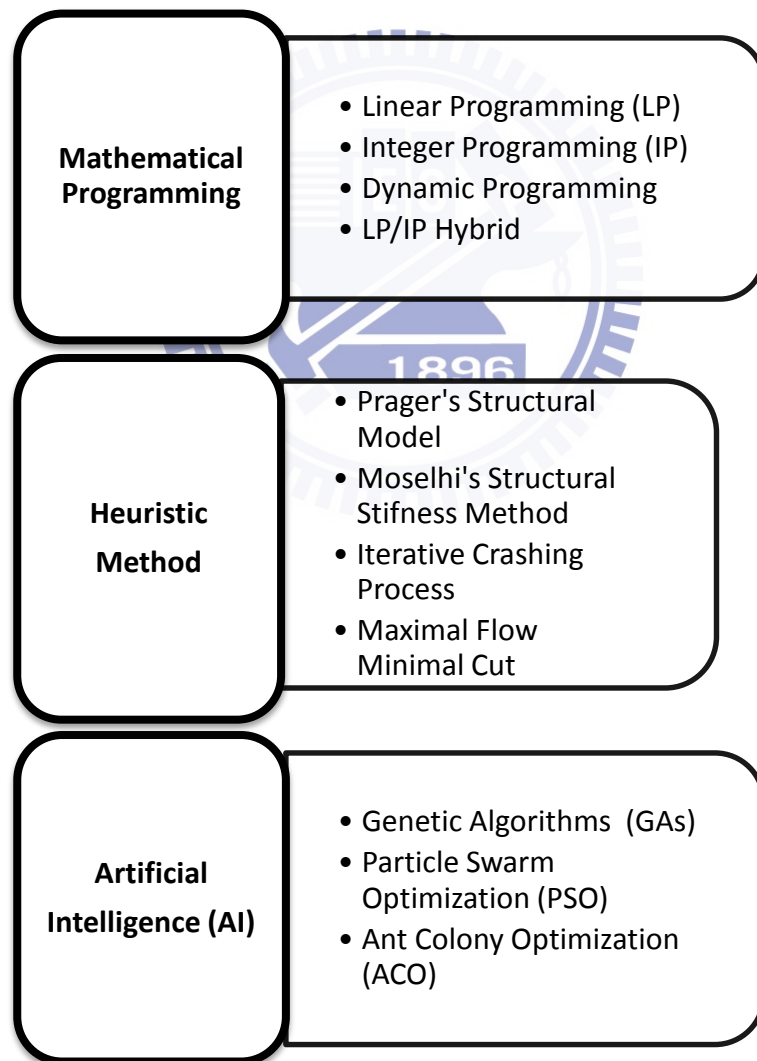

Figure 2.4 The existing techniques in solving TCTO problems

Summary

Mathematical approaches provide better solutions; however, the process of formulating the objective function and constraints is complex and prone to errors. Heuristic methods provide a way to obtain good solutions but do not guarantee optimality. However, they require less computational effort than mathematical methods. Therefore, artificial intelligence (AI) techniques are introduced such as genetic algorithms (GAs), particle swarm optimization (PSO), and ant colony optimization (ACO). PSO was developed to find the optimize complete time-cost profile called Pareto front over a set of feasible project durations considering all existing types of activity time-cost functions. Nonetheless, GAs do not guarantee optimal solution and usually require long computational time to reach reasonable solutions.

2.2 Genetic Algorithms (GAs)

GAs are search algorithms that is first developed by Holland (1975), which are based on the mechanics of natural selection and genetics to search through decision space for optimal solutions (Goldberg 1989).

The metaphor underlying GAs is natural selection. In evolution, the problem each species faces is to search for beneficial adaptations to the complicated and changing environment. In other words, each species has to change its chromosome combination to survive in the living world.

In GAs, a string represents a set of decisions (chromosome combination), a potential solution to a problem. Each string is evaluated on its performance with respect to the fitness function (objective function). The ones with better performance (fitness value) are more likely to survive than the ones with worse performance. Then the genetic information is exchanged between strings by crossover and perturbed by mutation. The result is a new generation with (usually) better survival abilities. This process is repeated until the strings in the new generation are identical, or certain termination conditions are met. A simple GA can be summarized as appears in the following section.(Feng, Liu, and Member, 1997). Figure 2.5 shows the operation of genetic algorithms.

The genetic algorithm performed best (compared to exact solution methods) on the problems with multi-modal activities. The extra combinations introduced by the multiple execution modes did not hurt the genetic algorithm performance. In fact, in some cases it made the problem easier for the genetic algorithm whereas it made the search more difficult for the branch and bound methods. This suggests that the genetic algorithm (or a hybrid which includes some kind of genetic algorithm variant) is well-suited to more-complicated problems with a mix of continuous and discrete components

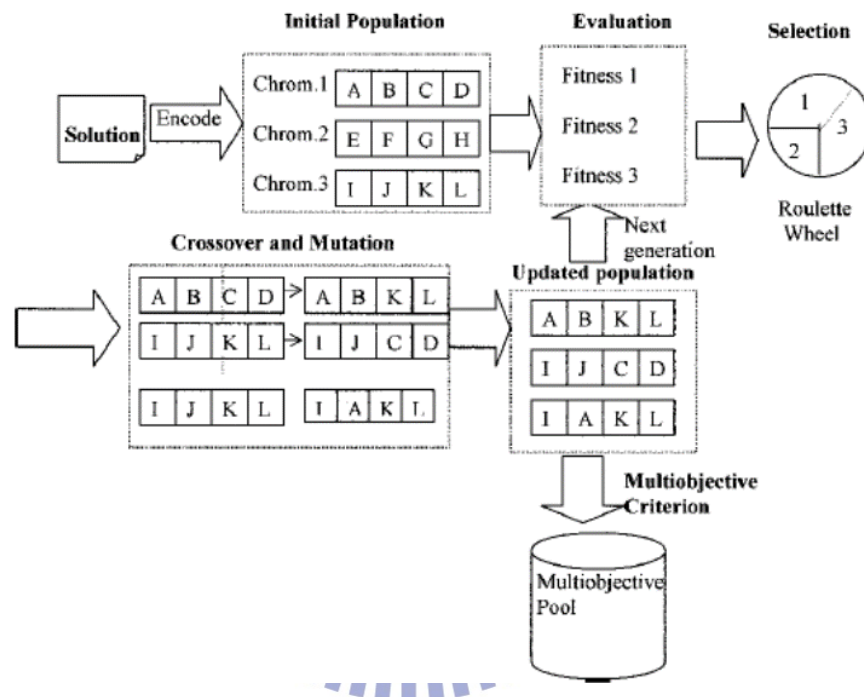

Figure 2.5 Operation of genetic algorithms (Zheng, Thomas, and Kumaraswamy,2004)

The genetic algorithm performed best (compared to exact solution methods) on the problems with multi-modal activities. The extra combinations introduced by the multiple execution modes did not hurt the genetic algorithm performance. In fact, in some cases it made the problem easier for the genetic algorithm whereas it made the search more difficult for the branch and bound methods. This suggests that the genetic algorithm (or a hybrid which includes some kind of genetic algorithm variant) is well-suited to more-complicated problems with a mix of continuous and discrete components.

However, GAs are shown to be able to obtain good solutions within an acceptable time frame but requires more advanced techniques such as niche formation (Yang 2007). Tazawa et al. (1996) also mentioned the weakness of

this method that GAs was not effective for the local search solutions for the space-based crossover-search and population diversity often decreases rapidly. GAs and also require a long time during the process of completion.

Summary

Genetic algorithm performed best (compared to exact solution methods) on the problems with multi-modal activities. The multiple execution modes that introduced extra combinations did not hurt the performance of genetic algorithm. In fact, in some cases it made the problem easier for the genetic algorithm, whereas it made the search more difficult for the branch and bound methods. This Suggests that the genetic algorithm (or hybrid roommates include some kind of genetic algorithm variant) is well-suited to more-complicated problems with a mix of continuous and discrete components.

2.3 Discounted Cash Flows (DCFs)

It is common that value of money decreases with time that is shown in Figure 2.6. The value of a given sum of money depends not only on the amount of money but also on when the money is received or paid (White et al. 1998). In traditional TCTO analysis, the value of money is assumed to remain constant whatever the project time span is. Although this assumption is not true, but it is realistic in molding TCTO problem with DCFs.

In other words, costs of activities are summed up to form project direct cost, although activities are executed at different times as their start and finish times are scheduled. However, money has a time value and therefore, it is significant to consider the time at which costs are incurred.

For projects with longer duration consideration of a time value of money becomes more significant. Among many economic measures, the net present value is most commonly used one. Most of the existing techniques for solving TCTO problem do not consider a time value of money.

Discounted cash flows (DCF) analysis of TCTO problem is important for both owners and contractors. Generally speaking, for a fixed value of total bid, it is preferable for owners to select the bid with the least net present value. On the other hand, contractors prefer deciding on the tender with the least value to bid while maximizing the net present value as in unbalanced bidding strategy. (Ammar 2010)

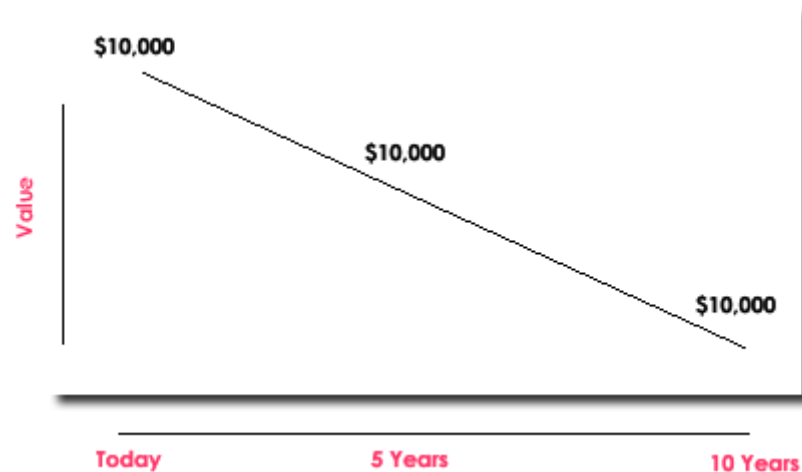

Figure 2.6 Time value of money graph

Summary

As mentioned before, it is obvious that ignoring a time value of money in the decision making of project problem can produce misleading decisions. The selected duration for activities and consequently, the optimum project duration depends on interest rate value chosen and indirect cost rates. But, should we always involve it in the analysis of TCTO problem even though the interest rates are very low? Some countries with very base interest rates such as Japan, Switzerland, etc., maybe can ignore a time value of money in the analysis of TCTO problem.

2.4 Uncertainty on Project Time-Cost Trade-Off (TCTO)

Construction time-cost trade-off problems are viewed as one of the most important aspects of construction decision making (Feng et al. 1997).

Difficulties arise because, for the hundreds of activities of a project, there are various options of completing these activities using different crew sizes or equipment. This creates the classic combinatorial search problem for construction engineers to identify the best selections of crew size or equipment that produce the minimum cost possible to complete the project. Traditionally, the time and cost for the options to complete an activity are assumed to be deterministic in construction time-cost trade-off analysis (Harris 1978), but in reality they typically follow a certain kind of probabilistic distribution, as indicated by historical data. The stochastic nature of time and cost adds an additional dimension of complexity to the already hard to solve combinatorial problem.

Although most researchers recognize the fact that time-cost trade-off problems are stochastic by nature, most working solutions assume that time and cost for completing an activity are deterministic (De et al. 1995). However uncertainty in the problem have received less attention due its complexity. Therefore, most of the researches have been focused on deterministic problems. In real construction projects however, time and cost of activities may face significant changes due to existing uncertainty such as inflation, economy and social stresses, execution errors of contractor, design errors, natural events such as climate changes and etc. Therefore, cost of project may differ significantly because of these uncertainty.

Summary

The impact upon the uncertainty cost maybe will lead us to another solution that comparing to traditional analysis solution. In this research, a risk analysis approach will be used in solving time-cost trade off problem with discounted cash flows. Unlike the traditional models which focus primarily on the deterministic Time-Cost Trade-Off problem, this research will have the ability to adapt probabilistic environment. For the lower risk, the higher time and cost would be accrued for project execution. Project manager can adjust different risk acceptance level for direct cost and indirect cost separately.

CHAPTER 3

EXPERIMENTAL DESIGN

Many of Time-Cost Trade-Off (TCTO) problem solving methods have been researched such as mathematical and artificial intelligent (AI) approach. The aim of both approach are to obtain the optimal duration of TCTO problem. Evolver software was developed by Palisade to solve the optimization problem. This software is a based on Genetic Algorithms (GAs) optimization program add-ins.

This chapter presents how this study uses Evolver to optimize the TCTO problem with discounted cash flows consideration. A case problem example is used to illustrate the experimental design through the adjustment of interest rates and degree of uncertainty. In order to assess the uncertainty of project cost, @Risk software is used in this study in the Monte Carlo simulation process.

Figure 3.1 shows the flowchart of the experimental process through problem formulation, optimization, and simulation process. The first step is problem formulation between TCTO problems with Discounted Cash Flows (DCF). After that, case problem example data information is modelled in excel spreadsheet. Next, Evolver is used to do optimization process of this study. When the optimized results are obtained, @Risk is used as Monte Carlo Simulation software. Furthermore, since this study uses simulation process, one of the advantages is Probabilistic Risk Assessment (PRA) can be done.

3.1 Case project example description

To illustrate the developed mathematical model, consider the simple example project used by Moussourakis and Haksever (2004) and depicted by the precedence network shown in Figure 3.1. Different types of time-cost functions are used by Moussourakis and Haksever under two types for ranges of activity duration: continuous and discontinuous. A continuous range of activity duration contains no holes or gaps (linear and piecewise linear). A discontinuous

range, however, may contain some continuous sections, but the entire range is not continuous (linear with gaps in between, linear section and discrete point, and discrete points).

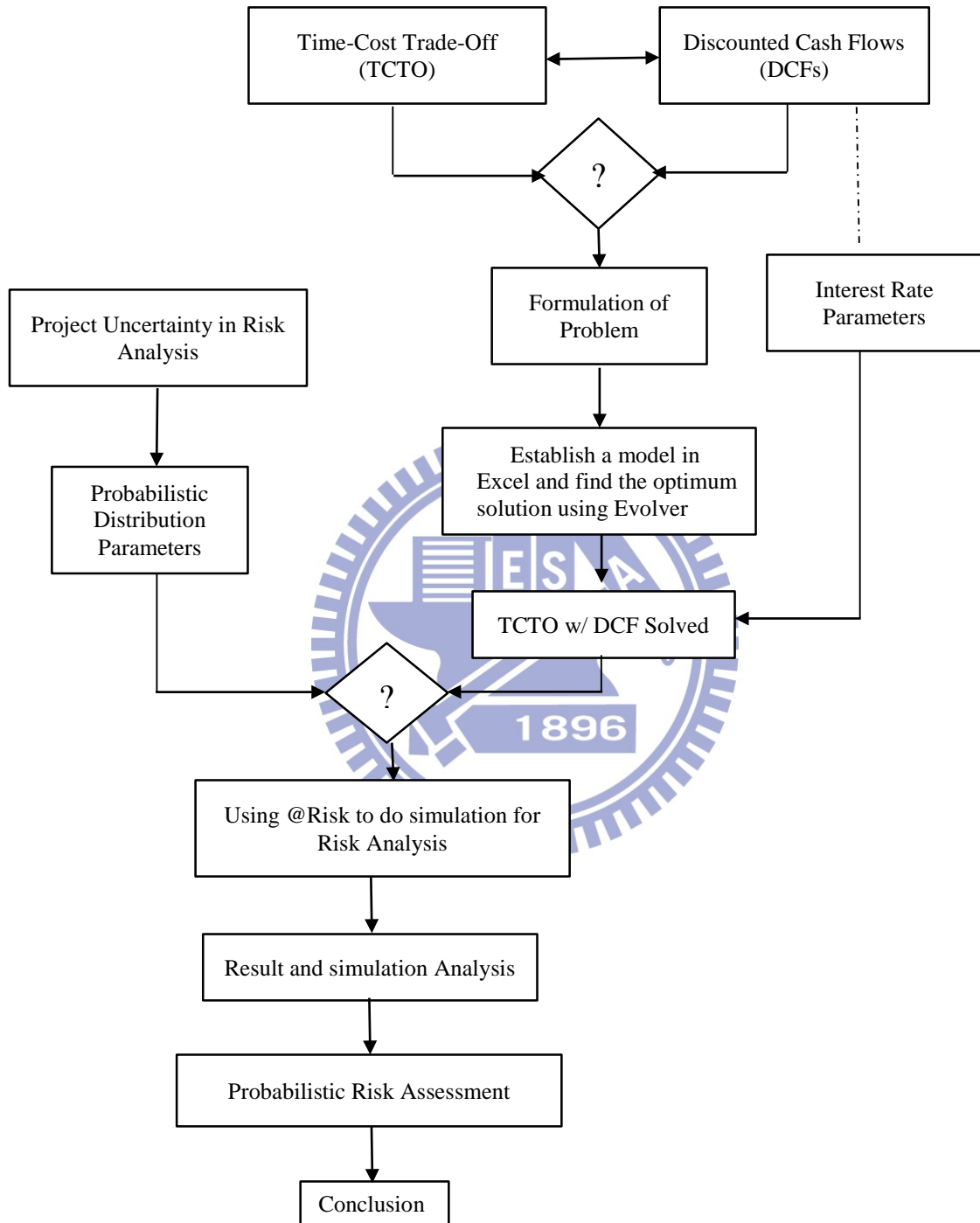

Figure 3.1 Flowchart of experiment process

The limitation of this study's case problem example as are follows:

1. This study adopts the case model example of previous study in the Mohammad A. Ammar (2010). This case model example is originally

used by Moussourakis and Haksever (2004). This case model example has different types of time-cost functions under two types for ranges of activity duration: continuous and discontinuous. A continuous range of activity duration contains no holes or gaps (linear and piecewise linear).

2. This study methodology uses Monte Carlo simulation in order to solve uncertainty cost. In order to simulate, this study uses beta general as probabilistic distributions in simulation.
3. This study uses 5th percentile and 95th percentile level from probabilistic simulation results in risk analysis.

3.1.1 CPM Network and Crashing Cost

CPM network of case project example is shown in the figure 3.2. Activities' time and cost data assumed by Moussourakis and Haksever are provided in Table 3.1. Cost slope values represent the extra cost associated with crashing an activity one week beyond its normal duration. In the present analysis, utility data are discrete at interval of unit duration (i.e., one week). The corresponding number of discrete points for each activity is also given in Table 3.1.

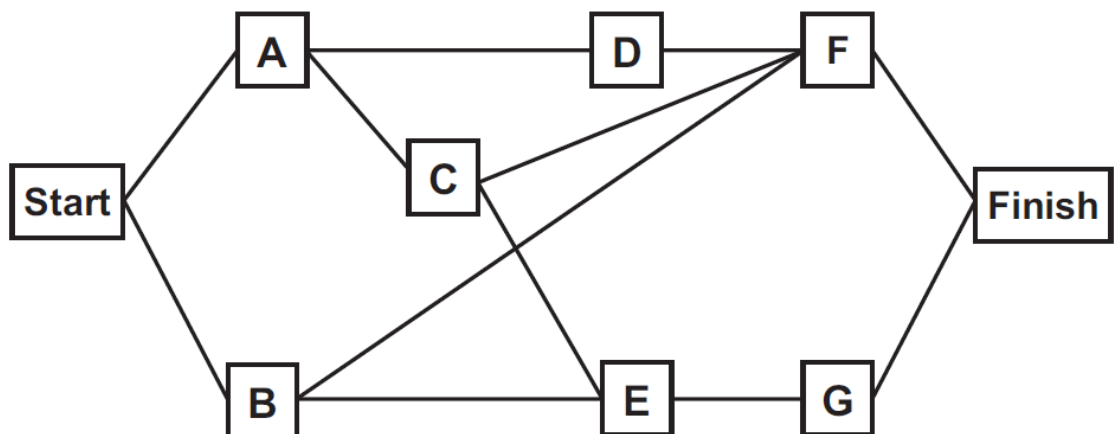

Figure 3.2 Precedence network of the example project

The project requires a total duration of 76 weeks to complete if all activities are performed at their normal durations. However, the all-crash solution produces a project completion time of 36 weeks. The all-normal

and all-crash project durations are the two extreme project time limits. The project indirect cost is assumed to be \$6/week.

The complete nonlinear mathematical model of the example project has been formulated. The input data are dependency relationships (predecessors), activities utility data, and discounting rate. The nonlinear model of the example project on hand consists of 77 variables while the number of constraints is 19.

In table 3.1, upper limit column shows the normal duration and cost of normal project, and lower limit shows its maximum values can be crashed. Each activity may have different options that have different of cost slope. Since each activities may have different time-cost functions, its discrete points were determined by integer duration value.

3.1.2 Interest rate

The time value of money is the principle that a certain currency amount of money today has a different buying power (value) than the same currency amount of money in the future. The value of money at a future point of time would take account of interest earned or inflation accrued over a given period of time. This notion exists both because there is an opportunity to earn interest on the money and because inflation will drive prices up, thus changing the "value" of the money.

However, in this research only focused to involve interest rate parameters into TCTO problem analysis. The interest rate parameters that are used in this case project example, is shown in Table 3.2. Table 3.2 shows the interest rates of major countries in July 2013 data. The variation of interest rate, which is 0.00% to 8.50%, will be used as the variable range consideration for the interest rate to analyze its impact on time-cost trade-off.

Table 3.2 Interest Rate Parameters (Source: <http://www.tradingeconomics.com>)

No.	Country	Interest rate
1	Japan, Switzerland	0.00%
2	USA	0.30%
3	Euro Area, Hong Kong, U.K	0.50%
4	Taiwan	1.88%
5	Malaysia	3.00%
6	Canada (Ammar,2010)	5.25%
7	Indonesia	6.50%
8	Brazil	8.50%

3.1.1 Probabilistic Parameters

Range estimating and probabilistic scheduling are estimating and scheduling techniques used to generate the cost estimate of a project as probability distributions. They involve defining the activity cost and as probability distributions rather than fixed deterministic quantities. Beta distribution was used as its probability distribution in this research.

Once distributions for the activity cost and duration have been defined, a Monte Carlo simulation algorithm (using the generation of random numbers) is applied to allow random sampling of these distributions. After a random cost and value, per activity, has been generated, all of the activity cost values are added together to determine the overall cost and schedule of the project. This process, when repeated a large number of times, results in a probability distribution for the total project cost and another for the total project schedule. Table 3.3 shows the 4 simulation models with various range of probabilistic distribution its parameter. The researcher enlarge its range in order to know the effect of range of distribution towards TCTO simulation solution.

Table 3.1 Activities Utility Data of the Example Project

Activity	Option	Duration (wk)		Cost (\$)		Cost slope (\$/wk)	Time-cost function	Number of discrete points
		Upper limit	Lower limit	Lower limit	Upper limit			
A	1	28	22	100	130	5.0	Piecewise linear	15
	2	22	18	140	210	17.5		
	3	18	16	240	250	5.0		
B	1	20	14	50	80	5.0	Linear with gaps in between	10
	2	10	8	120	300	90.0		
C	1	15	15	75	75	—	Discrete points	3
	2	8	8	240	240	—		
	3	4	4	500	500	—		
D	1	18	12	70	220	25.0	Linear section and discrete point	8
	2	5	5	360	360	—		
E	1	26	18	40	80	5.0	Piecewise linear	22
	2	18	14	200	240	10.0		
	3	14	6	240	260	2.5		
F	1	25	15	120	300	18.0	Linear	11
G	1	7	7	0	0	—	Discrete point	1

Table 3.3 Beta Probabilistic Parameters of Experiment Model Simulation

Experiment No.	Parameter				
	α_1	α_2	Min range	Max range	Δ range
Experiment I	52.55	78.83	80%	130%	50%
Experiment II	9.86	69.04	90%	170%	80%
Experiment III	5.01	50.1	90%	200%	110%
Experiment IV	8.33	62.49	80%	250%	170%

In this model simulation, the probabilistic mean cost values were set to be same as with deterministic cost values. The differentiation of each models is its probabilistic range that keep becoming larger in every model. To obtain the probabilistic mean value same as deterministic value, evolver software was used to get value its shape parameters, α_1 and α_2 , that determined its shape. The value of minimum in percentage (Experiment I, min= 80%, max=130%) means the minimum value for that simulation is 80 % of its deterministic cost value or mean of probabilistic value.

Figure 3.3-3.6 illustrate the probability density function graph of beta distribution that characterizes variability in cost of project. For example, Figure 3.3 shows the maximum range is 130% of mean value, minimum range is 80% of mean value and also standard deviation is 2.1289% of mean value.

Figure 3.7 shows the CDF of probability distribution betageneral Experiment I, Experiment II, Experiment III, Experiment IV. Degree of uncertainty each models' simulation increases by enlarger its max-minimum range probability. Figure 3.7 also illustrates the comparison probability distribution of each simulation model in this experiment studies. It obviously shows betageneral Experiment I has a lower degree of uncertainty than betageneral Experiment II.

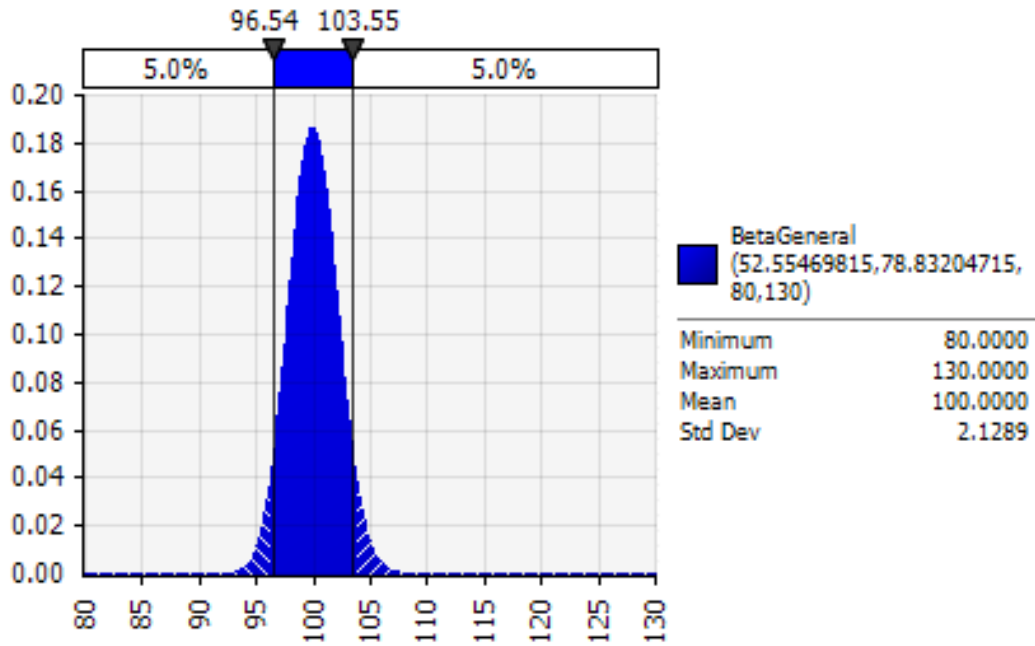

Figure 3.3 Simulation BetaGeneral Experiment I (52.55, 78.83, 20%, 130%)

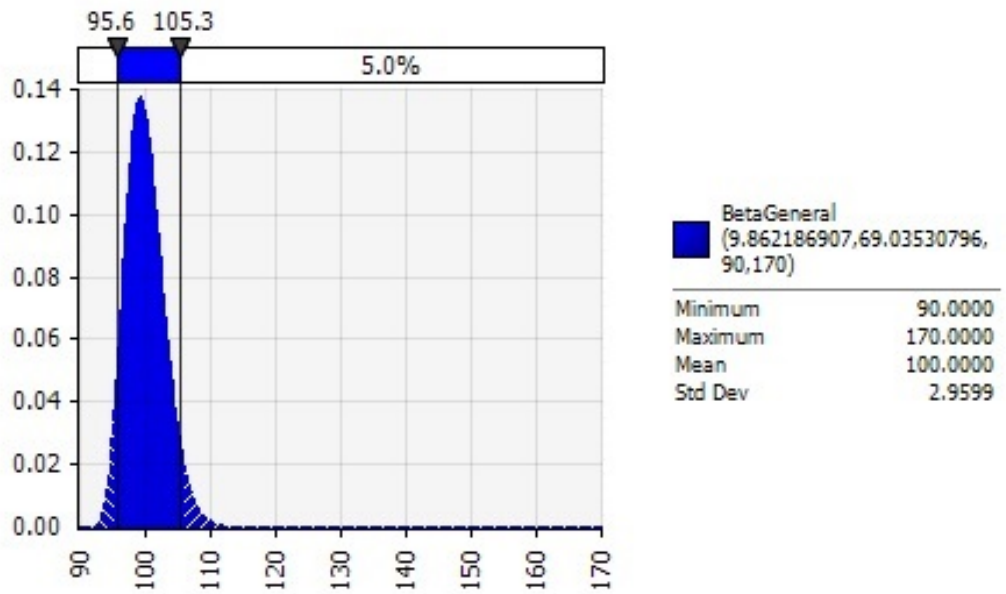

Figure 3.4 Simulation BetaGeneral Experiment II (9.86, 69.04, 90%, 170%)

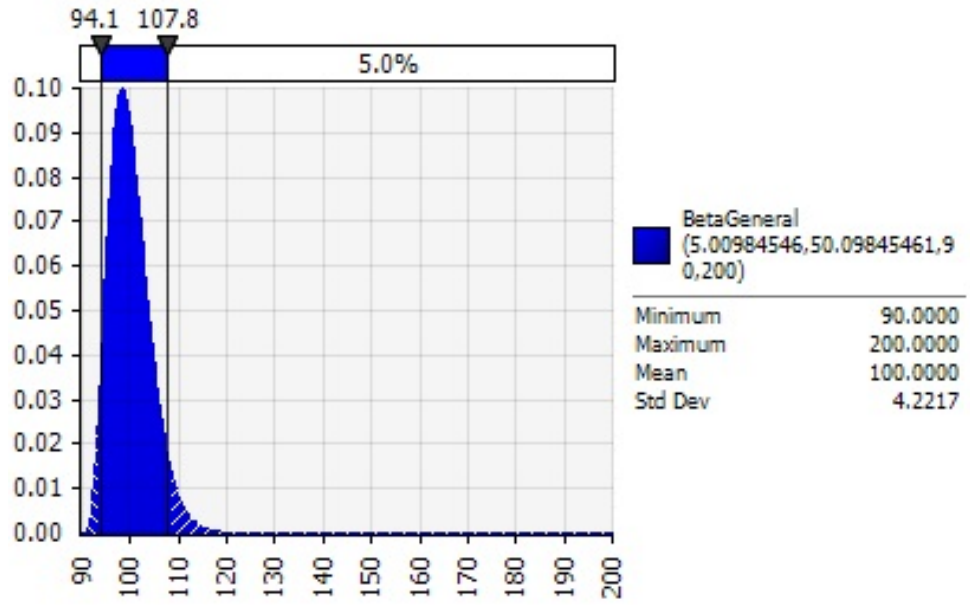

Figure 3.5 Simulation BetaGeneral Experiment III (5.01, 50.10, 90%, 200%)

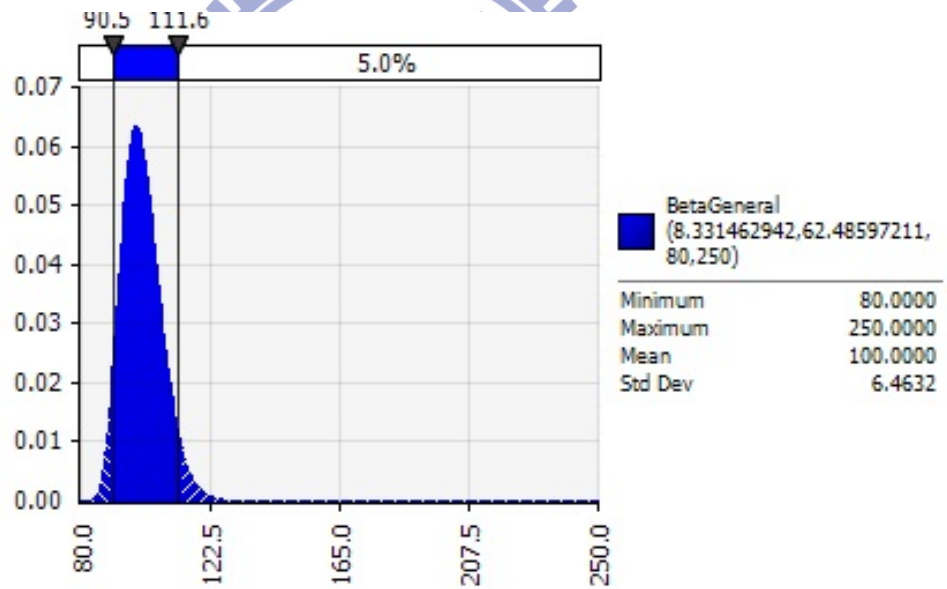

Figure 3.6 Simulation BetaGeneral Experiment IV (8.33, 62.49, 80%, 250%)

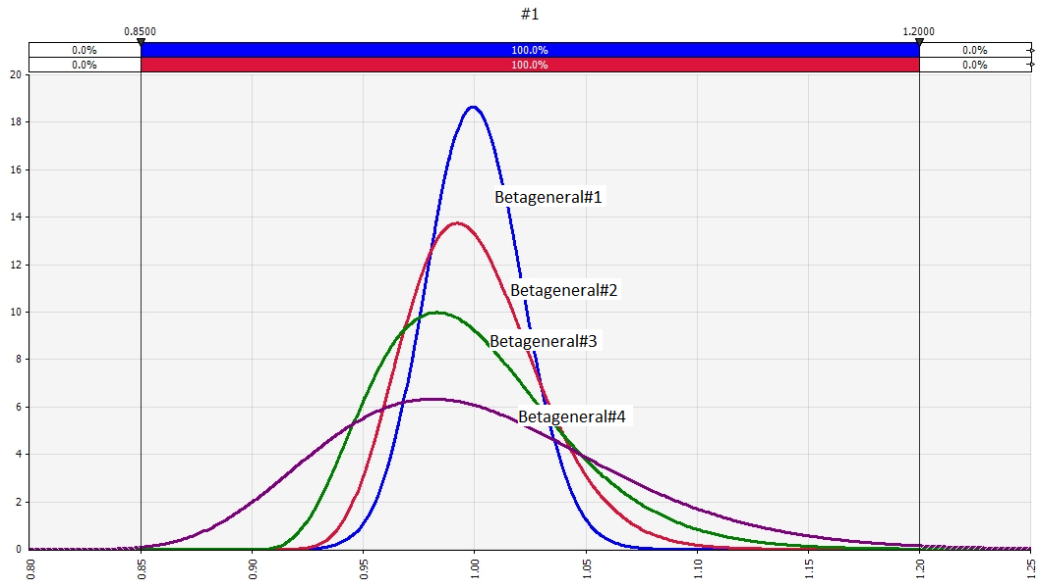

Figure 3.7 BetaGeneral Experiment I, Experiment II, Experiment III, and Experiment IV distribution overlay graphs

3.2 Formulation of problem model

Figure 3.8 shows the stepwise payment schedule, which represents most cases in the practical world where payments are received at certain time periods. However, this study treats the payment with a continuous linier function to simplify the calculation.

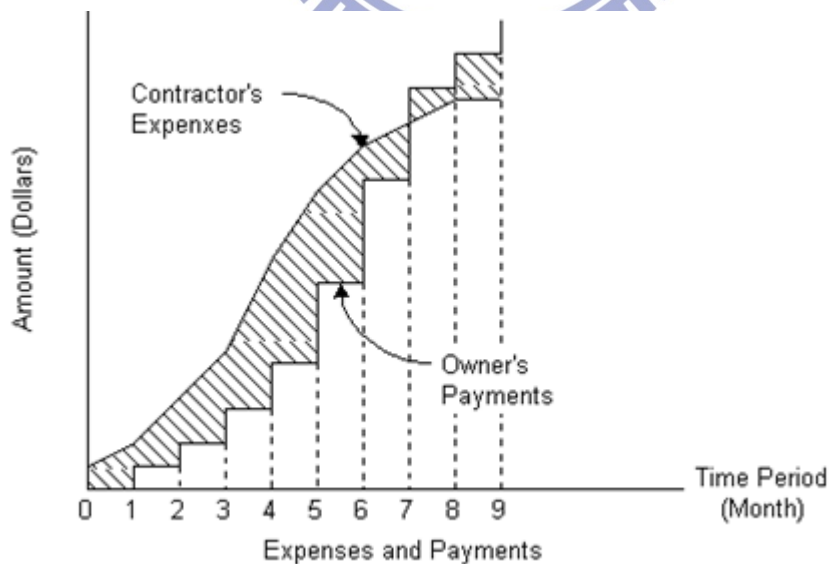

Figure 3.8 Contractor's Expenses and Owner's Payments (Source: PMBOOK)

In the present analysis, net present value will be used as economy measures

of time value of money. Future costs have to be discounted to a common point in time; say present time (or project start time). To consider the time value of money, the activity cost incurred at its scheduled finish (SF) has to be discounted by some factor. The discounted cost of an activity i can be calculated as

$$\text{Discounted cost}_i = C_i / (1 + r)^{\text{SF}_i} \quad (1)$$

in which C_i = cost of activity i ; SF_i is its scheduled finish; and $1/(1 + r)^{\text{SF}_i}$ = discount factor expressed in terms of interest rate (r). Discount factor in the exponential form, given in Eq. (1), is too complicated to be handled in a mathematical optimization model. Instead, a simplified form (but also practical) of Eq. (1) will be used. Since r is expressed as a fraction with values less than one, the discount factor $(1 + r)^{-\text{SF}_i}$ can be expanded in a polynomial form as

$$(1 + r)^{-\text{SF}_i} = 1 - r \times \text{SF}_i + r^2 \times \text{SF}_i^2 - r^3 \times \text{SF}_i^3 + \dots$$

From the practical point of view, units of activities' durations are usually days or even weeks. Also, interest rate usually has very small values compared to unity (i.e., $r \leq 1$). Therefore, higher order terms of the discount factor expansion can be truncated to become

$$\text{Discount factor} = 1 - r \times \text{SF}_i \quad (2)$$

Although the discount factor given by Eq. (2) is an approximation for the exact one expressed in Eq. (1), the recorded error can be neglected. For example, if r is taken 12% annually and durations are measured in weeks, the exact value of discount factor for a time period of 50 weeks is 0.8911 $\{1 / [1 + (0.12/52)] \times 50\}$ while the corresponding approximate value is 0.8846 $[1 - (0.12 / 52) \times 50]$ with an error value of 0.7%. For the same value of interest rate (i.e., 12%), the exact value of discount factor for a time period of 100 days is 0.967663 while the approximate value is 0.967123 (error = 0.06%). It is, therefore, very good approximation to use only the first two terms of Eq. (2) instead of using the exact formula. The compacted form of discount factor given by Eq. (2) will be adopted in the present analysis. The discounted cost of activity i given by Eq. (1) in terms of the adopted discount factor will be

$$\text{Discount cost}_i = C_i(1 - r \times \text{SF}_i) = C_i - r \times C_i \times \text{SF}_i \quad (3)$$

Consider a project having n activities, where utility data for project activities are represented by discrete functions. For each activity i , m_i discrete points are to be specified, where $m_i \geq 2$. Every discrete point represents a specific way of carrying out the activity. The normal (least cost) and crash (least duration) discrete points represent the two extremes of the activity time-cost function. For activities having only one discrete point, the normal and crash points coincide.

The primary information obtained from traditional scheduling are basically activities' start and finish timings (early and late) and floats. The duration and the corresponding cost for an activity are selected optimally from their utility data to satisfy the objective function and the imposed constraints. If the start time of an activity is determined, the finish time can be specified by adding the selected activity duration, and vice versa. The SF of activities will be used in the present model formulation, as will be illustrated after.

Decision Variables

A single zero-one (binary) variable, x , is needed for each discrete point in the utility data of each activity. Let D_i and C_i be the variables representing duration and cost of activity i , respectively. The duration and cost for an activity i , in terms of zero-one variables, can be expressed as follows:

$$D_i = d_{i1}x_{i1} + d_{i2}x_{i2} + \dots + d_{im_i}x_{im_i} = \sum_{j=1}^{m_i} d_{ij}x_{ij} \quad (4)$$

and

$$C_i = \sum_{j=1}^{m_i} c_{ij}x_{ij} \quad (5)$$

in which x_{ij} = zero-one variable belongs to the discrete point number j for activity i and d_{ij} and c_{ij} = j duration and cost of activity i . Zero-one variables are introduced to ensure that only one construction method (discrete point) is selected per activity.

Zero-One Variables Constraints

The mathematical model can be forced to select a single construction method per activity (duration and the corresponding cost) at a time for an activity i if the following condition is satisfied:

$$\sum_{j=1}^{m_i} x_{ij} = 1 \quad i = 1, 2, \dots, n \quad (6)$$

This type of constraint will be referred to as zero-one variables constraint. Since every discrete point requires zero-one variable, the number of zero-one variables needed is the sum of discrete points for all activities, while required number of zero-one constraints equals number of project activities, n .

Network Logic Constraint

The completion time of a project could be constrained by one of two methods (Crowston 1970). The first approach is to allow for a precedence constraint for each immediate preceding relationship in the project network. This approach was used in almost all existing optimization techniques (e.g., Liu et al. 1995; Eldosouky et al. 1991; Cusack 1985; Perera 1982; Kapur 1973; Meyer and Shaffer 1965). The second is to allow for one constraint for each path from the first activity to the last one in the project network. In the present model, the first approach will be adopted.

The logical relationship between any two consecutive activities i and its immediate predecessor, p , is expressed mathematically as

$$SS_i \geq SF_p$$

where SS_i = scheduled start of activity i and SF_p = scheduled finish of its predecessor p . The SF of activity i , equals its SS_i plus its duration. The logical relationship constraint can, then, be expressed by Eq. (7), in which NP_i is the number of preceding activities to activity i

$$SF_i - SF_p - \sum_{j=1}^{m_i} d_{ij}x_{ij} \geq 0, \quad p = 1, 2, \dots, NP_i \quad (7)$$

Project Completion Constraint (s)

Project completion is controlled by the latest finish time of ending activities. If the number of ending activities is denoted by NE, the project completion constraint(s) is given by Eq. (8), in which β is the desired project duration

$$SF_k \leq \beta, \quad k = 1, 2, \dots, NE \quad (8)$$

The upper and lower bounds on A are the all-normal project duration and all-crash project duration, respectively.

Objective Function

In traditional TCTO analysis, the objective function is usually set to minimize the project cost. This objective of minimizing project cost is, also, adopted in the present model formulation. Since indirect cost increases linearly with project duration and usually represented as a single cost per time period (Ahuja 1984), project direct cost only needs to be minimized. The project direct cost is the summation of all activities' costs expressed mathematically by

$$\text{Project direct cost(PDC)} = \sum_{i=1}^n \sum_{j=1}^{m_i} c_{ij}x_{ij} \quad (9)$$

In Eq. (9), time value of activity cost incurred at different points of time (finish time of activities) is ignored. If the time value of money is to be considered, costs of activities have to be discounted to the project start time. Introducing the discounting factor expressed by Eq. (2) to the project direct cost given by Eq. (9), it becomes

$$\text{Discounted PDC} = \sum_{i=1}^n \sum_{j=1}^{m_i} c_{ij}x_{ij} - r^* \sum_{i=1}^n \sum_{j=1}^{m_i} c_{ij}SF_i x_{ij} \quad (10)$$

The complete mathematical model can be summarized as follows:

$$\text{Minimize: discounted PDC} = \sum_{i=1}^n \sum_{j=1}^{m_i} c_{ij}x_{ij} - r^* \sum_{i=1}^n \sum_{j=1}^{m_i} c_{ij}SF_i x_{ij}$$

subject to

$$(a) \sum_{j=1}^{m_i} x_{ij} = 1, \quad i = 1, 2, \dots, n$$

$$(b) SF_i - SF_p - \sum_{j=1}^{m_i} d_{ij}x_{ij} \geq 0, \quad p = 1, 2, \dots, NP_i$$

$$(c) SF_k \leq \lambda, \quad k = 1, 2, \dots, NE$$

As some terms in the objective function are the product of two decision variables, the proposed model takes the standard form of nonlinear mathematical programming. The model requires as input precedence relationship of project activities in the form of finish to start and activities discrete point utility data. Making use of these data, the project is analyzed to get both the all-normal and all-crash project durations. For each feasible project duration, the optimization model selects the optimum duration and cost for each activity. The project time-cost curve is then determined by adding the indirect cost component. Consequently, the optimum project duration can be specified, as will be illustrated by the following example project. (Ammar, 2010)

The following symbols are used in the problem formulation:

- C_i = cost of activity i ;
- c_{ij} = cost of activity i corresponding to discrete point number j ;
- D_i = duration of activity i ;
- d_{ij} = duration of activity i corresponding to discrete point number j ;
- NE = number of ending activities (having no successors);
- NP_i = number of predecessors of activity i ;
- n = number of activities comprising a project;
- m_i = number of discrete points belongs to activity i ;
- PDC = project direct cost;
- r = nominal interest rate;
- SF_i = scheduled finish of activity i ;
- x_{ij} = zero-one variable for activity i corresponding to discrete point number j ; and
- λ = desired project duration.

3.3 Solving TCTO with DCFs problem

TCTO problem was solved using Excel spreadsheets with add-ins software that called Evolver. The data from Table 3.1 and 3.2 were entered into the spreadsheet shown in Figure 3.9 and 3.11. At the top of the spreadsheet the specified deadline is entered in cell B2 and the total cost of completing the project including both direct cost and indirect cost is calculated in cell B5. Below this, column A to G contain the information given in the Table 4.1. Cell B1 is the input of interest rate. In cells I9:I15 another table was created to keep track of the event times of its node. Table at A20:C25 And Figure 3.11 contains the crashing cost information from Table 3.1 with all of the discrete points from time-cost function are showed.

$$\text{Cost} = \frac{\text{Activity Cost before DCFs}}{(1 + \text{interest rate})^{\frac{\text{Event time}}{52 \text{ weeks}}}}$$

For example to determine cost for activity A with 70 weeks solution duration and interest rate 0.50%

$$\text{Activity A Cost} = \frac{\$110}{(1 + 0.05)^{\frac{27 \text{ weeks}}{52 \text{ weeks}}}}$$

$$\text{Activity A Cost} = \$107.25$$

Once all of the TCTO project example data have been put in spreadsheets, now the following step will show how Evolver add-ins software in Excel can be used to determine activities to crash so that the entire project is completed within given deadline time at the minimum total cost. To begin select Evolver from the menu bar and the select model definition, Evolver model dialog box is now displayed (see Figure 3.10).

In this case, the objective is to minimize the cost of completing the project, which is calculated in cell B5. To specify this, we select optimization Goal at minimum with cell B5 as its goal cell. And then select the limitation range of its adjustable cell, which is in cell A20:A25. After that, set the constraints with formula the total duration should be equal with the given deadline duration, but those constraints could be left black if need to find the optimal solution duration of TCTO problem.

	A	B	C	D	E	F	G	H	I
1	r	0.00%							
2	Deadline	70							
3	Direct Cost	\$ -							
4	Indirect Cost	\$ -							
5	Total Cost	\$ -							
6									
7							r=	0.00%	
8	Activity	Predecessors	Normal Duration	Crash Duration	Normal Cost	Crash Cost	Duration	Cost	Event Time
9	A	-	28	16	\$ 130	\$ 250			0
10	B	-	20	8	\$ 50	\$ 300			0
11	C	A	15	4	\$ 75	\$ 500			0
12	D	A	18	5	\$ 70	\$ 360			0
13	E	B,C	26	6	\$ 40	\$ 260			0
14	F	B,C,D	25	15	\$ 120	\$ 300			0
15	G	E	7	7	\$ -	\$ -			0
16	Total				\$ 485				0
17									
18	Help								
19	Adjustable Cell Value	Min	Max						
20		1	15						
21		1	10						
22		1	3						
23		1	8						
24		1	23						
25		1	11						

Figure 3.9 Excel Spreadsheet for TCTO with DCFs

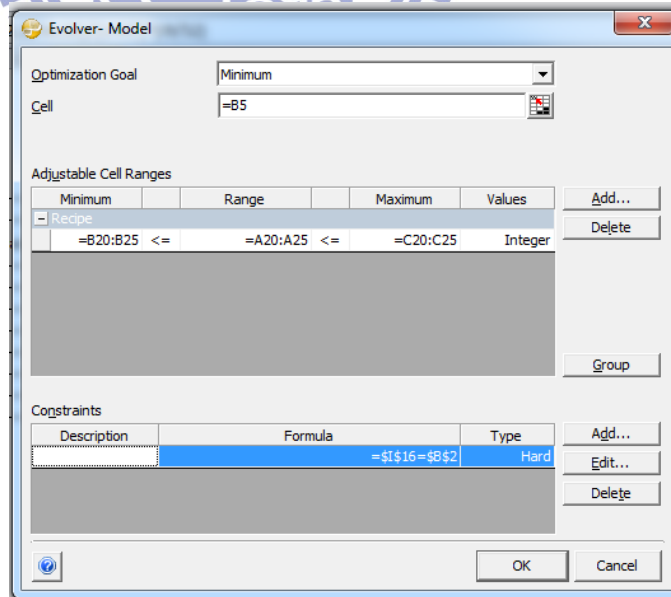

Figure 3.10 Evolver model dialog box

	A	B	C	D	E
26					
27	Activity	Option		Duration	Cost (\$)
28	A	1	1	28	\$ 100.00
29			2	27	\$ 105.00
30			3	26	\$ 110.00
31			4	25	\$ 115.00
32			5	24	\$ 120.00
33			6	23	\$ 125.00
34			7	22	\$ 130.00
35		2	8	22	\$ 140.00
36			9	21	\$ 157.50
37			10	20	\$ 175.00
38			11	19	\$ 192.50
39			12	18	\$ 210.00
40		3	13	18	\$ 240.00
41			14	17	\$ 245.00
42			15	16	\$ 250.00
43	B	1	1	20	\$ 50.00
44			2	19	\$ 55.00
45			3	18	\$ 60.00
46			4	17	\$ 65.00
47			5	16	\$ 70.00
48			6	15	\$ 75.00
49			7	14	\$ 80.00
50		2	8	10	\$ 120.00
51			9	9	\$ 210.00
52			10	8	\$ 300.00
53	C	1	1	15	\$ 75.00
54		2	2	8	\$ 240.00
55		3	3	4	\$ 500.00
56	D	1	1	18	\$ 70.00
57			2	17	\$ 95.00
58			3	16	\$ 120.00
59			4	15	\$ 145.00
60			5	14	\$ 170.00
61			6	13	\$ 195.00
62			7	12	\$ 220.00
63	2	8	5	\$ 360.00	

	A	B	C	D	E
64	Activity	Option		Duration	Cost (\$)
65		1	1	26	\$ 40.00
66			2	25	\$ 45.00
67			3	24	\$ 50.00
68			4	23	\$ 55.00
69			5	22	\$ 60.00
70			6	21	\$ 65.00
71			7	20	\$ 70.00
72			8	19	\$ 75.00
73			9	18	\$ 80.00
74	E	2	10	18	\$ 200.00
75			11	17	\$ 210.00
76			12	16	\$ 220.00
77			13	15	\$ 230.00
78			14	14	\$ 240.00
79		3	15	14	\$ 240.00
80			16	13	\$ 242.50
81			17	12	\$ 245.00
82			18	11	\$ 247.50
83			19	10	\$ 250.00
84	20		9	\$ 252.50	
85	F	1	21	8	\$ 255.00
86			22	7	\$ 257.50
87			23	6	\$ 260.00
88			1	25	\$ 120.00
89			2	24	\$ 138.00
90			3	23	\$ 156.00
91			4	22	\$ 174.00
92			5	21	\$ 192.00
93			6	20	\$ 210.00
94			7	19	\$ 228.00
95			8	18	\$ 246.00
96	9	17	\$ 264.00		
97	10	16	\$ 282.00		
98	11	15	\$ 300.00		
99	G	1		7	0

Figure 3.11 Excel spreadsheet for crashing cost

After all of the parameters have been set, the next step just select the start button in menu bar and the software will run the optimization process to find the best duration. The result of optimization of 70-day solution is shown in Figure 3.12. In order to get all the TCTO solution from deadline duration 60 until 76, repeat all of the previous step again with adjust the deadline value from 60 until 76. Every time the solution result is shown, all of the data of duration and cost from column G and H were recorded. All of the solution duration and cost data results that have been optimized were shown in Table

3.4 (duration) and Table 3.5 (Cost). Table 3.4 shows the optimal duration that have been optimized of each activities. And Table 3.5 shows the cost of optimal duration each activities.

	A	B	C	D	E	F	G	H	I
1	r	0.00%							
2	Deadline	70							
3	Direct Cost	\$ 485.00							
4	Indirect Cost	\$ 420.00							
5	Total Cost	\$ 905.00							
6									
7							r=	0.00%	
8	Activity	Predecessors	Normal Duration	Crash Duration	Normal Cost	Crash Cost	Duration	Cost	Event Time
9	A	-	28	16	\$ 130	\$ 250	27	\$ 105.00	27
10	B	-	20	8	\$ 50	\$ 300	20	\$ 50.00	20
11	C	A	15	4	\$ 75	\$ 500	15	\$ 75.00	42
12	D	A	18	5	\$ 70	\$ 360	18	\$ 70.00	45
13	E	B,C	26	6	\$ 40	\$ 260	21	\$ 65.00	63
14	F	B,C,D	25	15	\$ 120	\$ 300	25	\$ 120.00	70
15	G	E	7	7	\$ -	\$ -	7	\$ -	70
16	Total				\$ 485			\$ 485.00	70
17									
18	Help								
19	Adjustable Cell Value	Min	Max						
20	2	1	15						
21	1	1	10						
22	1	1	3						
23	1	1	8						
24	6	1	23						
25	1	1	11						

Figure 3.12 Excel spreadsheet for crash problem, 70-day solution with 0% interest rate

Table 3.4 Optimal duration solution

Total Project Duration	Activity Duration						
	A	B	C	D	E	F	G
60	18	20	15	18	20	24	7
61	18	20	15	18	21	25	7
62	19	20	15	18	21	25	7
63	20	20	15	18	21	25	7
64	22	20	15	18	20	24	7
65	22	20	15	18	21	25	7
66	23	20	15	18	21	25	7
67	24	20	15	18	21	25	7
68	25	20	15	18	21	25	7
69	25	20	15	18	22	25	7
70	26	20	15	18	22	25	7
71	26	20	15	18	23	25	7
72	27	20	15	18	23	25	7
73	26	20	15	18	25	25	7
74	26	20	15	18	26	25	7
75	28	20	15	18	25	25	7
76	28	20	15	18	26	25	7

Table 3.5 Total minimum project cost with optimal duration solution

No.	Interest Rate	Optimal Project Duration (weeks)	Activity Cost (\$)							Direct Cost	Indirect Cost	Total Cost
			A	B	C	D	E	F	G			
1	0.00%	65	\$130.00	\$ 50.00	\$ 75.00	\$ 70.00	\$ 65.00	\$120.00	\$ -	\$510.00	\$390.00	\$390.00
2	0.30%	65	\$129.84	\$ 49.94	\$ 74.84	\$ 69.84	\$ 64.78	\$119.55	\$ -	\$508.79	\$388.54	\$388.54
3	0.50%	65	\$129.73	\$ 49.90	\$ 74.73	\$ 69.73	\$ 64.64	\$119.25	\$ -	\$507.99	\$387.58	\$387.58
4	1.88%	65	\$128.98	\$ 49.64	\$ 74.01	\$ 69.00	\$ 63.66	\$117.24	\$ -	\$502.54	\$381.02	\$381.02
5	3.00%	65	\$128.38	\$ 49.43	\$ 73.44	\$ 68.43	\$ 62.89	\$115.65	\$ -	\$498.22	\$375.85	\$375.85
6	5.25%	71	\$ 97.28	\$ 49.03	\$ 71.89	\$ 66.90	\$ 61.03	\$111.90	\$ -	\$458.04	\$397.25	\$397.25
7	6.25%	71	\$ 96.67	\$ 48.80	\$ 71.19	\$ 66.21	\$ 60.15	\$110.11	\$ -	\$453.14	\$390.90	\$390.90
8	8.50%	71	\$ 95.70	\$ 48.46	\$ 70.11	\$ 65.13	\$ 58.79	\$107.35	\$ -	\$445.53	\$381.10	\$381.10

3.4 Simulation using @Risk

The spreadsheets in Figure 3.14 and 3.15 are established in order to do simulation with @Risk. The cost data that obtained from previous step are input in mean column that has colored blue in Figure 3.14. And then, input the min and max range of probability distribution data. Cell M6 contains following betageneral formula;

$$\text{Mean} = \min + \frac{\alpha_1}{\alpha_1 + \alpha_2} (\text{max} - \min)$$

For example activity with deterministic cost value \$110;

$$\$110 = (80\% \times \$110) + \frac{\alpha_1}{\alpha_1 + \alpha_2} [(130\% \times \$110) - (80\% \times \$110)],$$

$$\alpha_1 = 52.22$$

$$\alpha_2 = 78.83$$

Cell K2 (α_1) and L2 (α_2) are set as adjustable cell with optimization goal target value deterministic cost value (110), the evolver model dialog box is shown in Figure 3.13. Therefore the unknown variable α_1 and α_2 can be determined using Evolver. After the value of α_1 and α_2 were obtained, those values would be used in the simulation with parameter Betageneral Experiment I (52.55, 78.83, 80%, 130%).

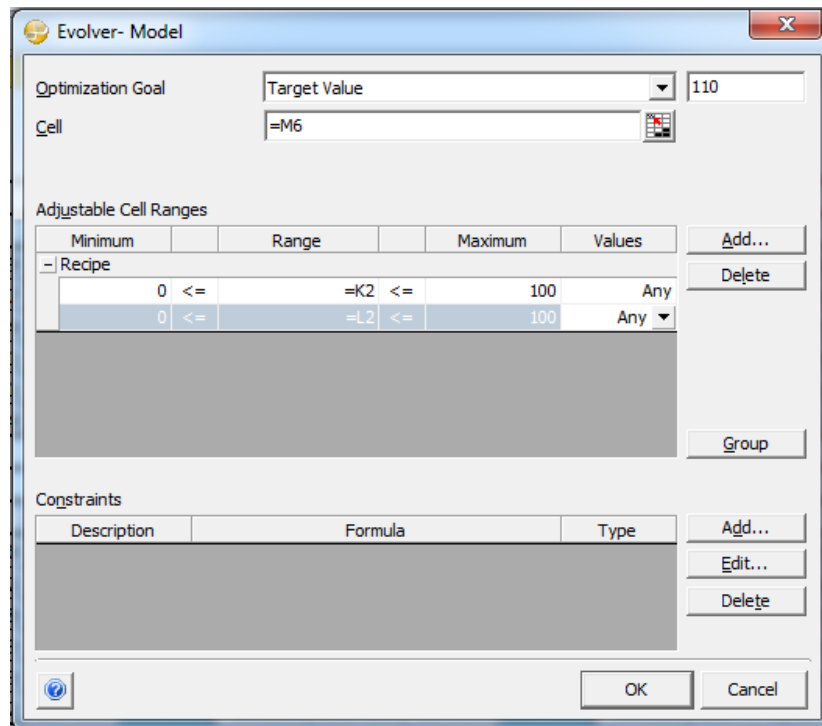

Figure 3.13 Evolver model dialog box to determine α_1 and α_2

	J	K	L	M	N	O	P	Q	R	S
1			$\alpha 1$	$\alpha 2$	min	max				
2			52.55	78.83	80%	130%				
3										
4			r=0%				r=0.3%			
5		Activity	min	max	Probabilistic mean	Deterministic	min	max	Probabilistic mean	Deterministic
6		A	\$ 88.00	\$143.00	\$ 110.00	\$ 110.00	\$ 87.87	\$142.79	\$ 109.84	\$ 109.84
7		B	\$ 40.00	\$ 65.00	\$ 50.00	\$ 50.00	\$ 39.95	\$ 64.93	\$ 49.94	\$ 49.94
8		C	\$ 60.00	\$ 97.50	\$ 75.00	\$ 75.00	\$ 59.86	\$ 97.27	\$ 74.82	\$ 74.82
9		D	\$ 56.00	\$ 91.00	\$ 70.00	\$ 70.00	\$ 55.86	\$ 90.77	\$ 69.82	\$ 69.82
10		E	\$ 52.00	\$ 84.50	\$ 65.00	\$ 65.00	\$ 51.81	\$ 84.20	\$ 64.77	\$ 64.77
11		F	\$ 96.00	\$156.00	\$ 120.00	\$ 120.00	\$ 95.62	\$155.38	\$ 119.52	\$ 119.52
12										
13			r=0.5%				r=1.88%			
14		Activity	min	max	Probabilistic mean	Deterministic	min	max	Probabilistic mean	Deterministic
15		A	\$ 87.78	\$142.64	\$ 109.73	\$ 109.73	\$ 87.18	\$141.67	\$ 108.98	\$ 108.98
16		B	\$ 39.92	\$ 64.88	\$ 49.90	\$ 49.90	\$ 39.71	\$ 64.54	\$ 49.64	\$ 49.64
17		C	\$ 59.80	\$ 97.17	\$ 74.75	\$ 74.75	\$ 59.13	\$ 96.08	\$ 73.91	\$ 73.91
18		D	\$ 55.76	\$ 90.62	\$ 69.71	\$ 69.71	\$ 55.12	\$ 89.58	\$ 68.91	\$ 68.91
19		E	\$ 51.69	\$ 84.00	\$ 64.61	\$ 64.61	\$ 50.86	\$ 82.64	\$ 63.57	\$ 63.57
20		F	\$ 95.37	\$154.97	\$ 119.21	\$ 119.21	\$ 93.66	\$152.19	\$ 117.07	\$ 117.07
21										
22			r=3%				r=5.25%			
23		Activity	min	max	Probabilistic mean	Deterministic	min	max	Probabilistic mean	Deterministic
24		A	\$ 86.71	\$140.90	\$ 108.39	\$ 108.39	\$ 85.78	\$139.39	\$ 107.22	\$ 107.22
25		B	\$ 39.55	\$ 64.27	\$ 49.43	\$ 49.43	\$ 39.22	\$ 63.73	\$ 49.03	\$ 49.03
26		C	\$ 58.62	\$ 95.25	\$ 73.27	\$ 73.27	\$ 57.63	\$ 93.64	\$ 72.03	\$ 72.03
27		D	\$ 54.62	\$ 88.75	\$ 68.27	\$ 68.27	\$ 53.63	\$ 87.14	\$ 67.03	\$ 67.03
28		E	\$ 50.20	\$ 81.57	\$ 62.75	\$ 62.75	\$ 48.92	\$ 79.50	\$ 61.15	\$ 61.15
29		F	\$ 92.31	\$150.00	\$ 115.38	\$ 115.38	\$ 89.70	\$145.76	\$ 112.12	\$ 112.12
30										
31			r=6.5%				r=8.5%			
32		Activity	min	max	Probabilistic mean	Deterministic	min	max	Probabilistic mean	Deterministic
33		A	\$ 85.27	\$138.57	\$ 106.59	\$ 106.59	\$ 84.48	\$137.28	\$ 105.60	\$ 105.60
34		B	\$ 39.04	\$ 63.44	\$ 48.80	\$ 48.80	\$ 38.76	\$ 62.99	\$ 48.46	\$ 48.46
35		C	\$ 57.09	\$ 92.78	\$ 71.37	\$ 71.37	\$ 56.26	\$ 91.43	\$ 70.33	\$ 70.33
36		D	\$ 53.09	\$ 86.28	\$ 66.37	\$ 66.37	\$ 52.26	\$ 84.93	\$ 65.33	\$ 65.33
37		E	\$ 48.24	\$ 78.39	\$ 60.30	\$ 60.30	\$ 47.18	\$ 76.67	\$ 58.98	\$ 58.98
38		F	\$ 88.30	\$143.49	\$ 110.38	\$ 110.38	\$ 86.15	\$139.99	\$ 107.69	\$ 107.69

Figure 3.14 @Risk BetaGeneral Experiment I (52.55, 78.83, 80%, 130%) spreadsheets (1)

The next step is define distributions, fill the cell cost from column B to I with formula =RiskBetaGeneral(alpha1,alpha2,minimum,maximum) and then add output of simulation in total cost cell B15:I15. Once all of the parameters have been determined, the last step is process the simulation with iterations 10000. The complete simulation output result can be referred in appendixes section.

	A	B	C	D	E	F	G	H	I
1	interest	0.00%	0.30%	0.50%	1.88%	3.00%	5.25%	6.50%	8.50%
2	Total Duration	69							
3									
4	Activity	Cost							
5		r=0 %	r=0.3 %	r=0.5 %	r=1.88 %	r=3 %	r=5.25 %	r= 6.5 %	r= 8.5 %
6	A	\$ 110.00	\$ 109.84	\$ 109.73	\$ 108.98	\$ 108.39	\$ 107.22	\$ 106.59	\$ 105.60
7	B	\$ 50.00	\$ 49.94	\$ 49.90	\$ 49.64	\$ 49.43	\$ 49.03	\$ 48.80	\$ 48.46
8	C	\$ 75.00	\$ 74.82	\$ 74.75	\$ 73.91	\$ 73.27	\$ 72.03	\$ 71.37	\$ 70.33
9	D	\$ 70.00	\$ 69.82	\$ 69.71	\$ 68.91	\$ 68.27	\$ 67.03	\$ 66.37	\$ 65.33
10	E	\$ 65.00	\$ 64.77	\$ 64.61	\$ 63.57	\$ 62.75	\$ 61.15	\$ 60.30	\$ 58.98
11	F	\$ 120.00	\$ 119.52	\$ 119.21	\$ 117.07	\$ 115.38	\$ 112.12	\$ 110.38	\$ 107.69
12	G	\$ -	\$ -	\$ -	\$ -	\$ -	\$ -	\$ -	\$ -
13	Direct Cost	\$ 490.00	\$ 488.72	\$ 487.91	\$ 482.08	\$ 477.50	\$ 468.59	\$ 463.81	\$ 456.38
14	Indirect Cost	\$ 414.00	\$ 412.36	\$ 411.27	\$ 403.89	\$ 398.08	\$ 386.82	\$ 380.81	\$ 371.52
15	Total Cost	\$ 904.0	\$ 901.1	\$ 899.2	\$ 886.0	\$ 875.6	\$ 855.4	\$ 844.6	\$ 827.9

Figure 3.15 @Risk BetaGeneral Experiment I (52.55, 78.83, 80%, 130%) spreadsheets (2)

In summary, the procedure of time-cost trade-off analysis is as follows.

1. Formulate CPM network each activities in event time,
2. Define all the parameters to be experimented such as interest rates and probabilistic range.
3. Using Evolver to obtain the optimal duration solution from 60 through 76 target duration,
4. Using Evolver to define beta distributions by adjust its probabilistic mean value same as deterministic mean value as well,
5. Simulating the uncertainty model with setting of 10000 iterations and sampling type latin hybercube,
6. Repeat the step (3)and (4) by enlarge distribution range to increase its degree of uncertainty,
7. Classify each simulation output results (5th percentile values and 95th percentile values) and,
8. Establish minimum time-cost curve.

CHAPTER 4

RESULTS AND ANALYSIS

This chapter presents the results of an optimization process and a simulation process. It also presents the analysis of the impact of the time value of money on the time-cost trade-off (TCTO). Furthermore, since this study uses the simulation process, in addition, the probabilistic risk assessment can be analyzed in this chapter.

4.1 TCTO with DFCs Result and Analysis

Table 4.1 shows the total cost of the project for both traditional and DCF analysis of the TCTO problem. As expected, the DCF analysis had a significant impact on the total cost of the project. The optimal project duration (corresponding to the minimum total cost) if the time value of money is ignored (i.e., $r = 0\%$) is 65 weeks, which is identical to that given by Moussourakis and Haksever (2004). However, if the value starts at 5.25% to 8.50% interest rates, the corresponding optimal project duration would be 71 weeks (Table 4.1).

Figure 4.1 shows the optimal results in a time-cost relationship graph. It is clearly apparent in Figure 4.1 that there is a distinct value for optimal project duration if the time value of money is ignored (65 weeks). This may not be the case for projects with a different network configuration, a different activity utility data, and other values of interest rate.

Figure 4.2 also shows that when higher interest rates ($> 8.5\%$) are applied, the optimum solution duration for interest rates of 12% and 15% is 76 weeks. When the time value of money is ignored, 65 weeks shows as the first optimum duration, 71 weeks shows as the seventh optimum duration, and 76 weeks shows as the twelfth optimum duration. Furthermore, when the time value of money is involved, 71 and 76 weeks show as best optimal durations for some certain value of interest rates. Nevertheless, when this study extends the interest rate, the

optimal duration also changes to 76 weeks for an interest rate of 12%.

Table 4.1. Total cost from optimal solution duration at various interest rates.

Duration /Interest	0.00%	0.30%	0.50%	1.88%	3.00%	5.25%	6.50%	8.50%
60	\$ 973.00	\$ 970.51	\$ 968.84	\$ 957.61	\$ 948.71	\$ 931.40	\$ 922.10	\$ 907.66
61	\$ 956.00	\$ 953.53	\$ 951.88	\$ 940.77	\$ 936.68	\$ 914.83	\$ 905.63	\$ 891.35
62	\$ 944.50	\$ 941.98	\$ 940.30	\$ 928.93	\$ 919.94	\$ 902.45	\$ 893.05	\$ 878.48
63	\$ 933.00	\$ 930.42	\$ 928.71	\$ 917.11	\$ 907.93	\$ 890.09	\$ 878.64	\$ 865.66
64	\$ 917.00	\$ 914.31	\$ 912.53	\$ 900.39	\$ 890.80	\$ 872.18	\$ 862.19	\$ 852.87
65	\$ 900.00	\$ 897.33	\$ 895.58	\$ 883.57	\$ 874.08	\$ 855.65	\$ 845.77	\$ 830.46
66	\$ 901.00	\$ 898.27	\$ 896.48	\$ 884.17	\$ 874.45	\$ 855.60	\$ 845.48	\$ 829.82
67	\$ 902.00	\$ 899.20	\$ 897.38	\$ 884.77	\$ 874.83	\$ 855.54	\$ 845.20	\$ 829.18
68	\$ 903.00	\$ 900.14	\$ 898.28	\$ 885.37	\$ 875.20	\$ 855.48	\$ 844.91	\$ 828.54
69	\$ 904.00	\$ 901.07	\$ 899.18	\$ 885.97	\$ 875.57	\$ 855.42	\$ 844.62	\$ 827.91
70	\$ 905.00	\$ 902.01	\$ 900.07	\$ 886.57	\$ 875.95	\$ 855.35	\$ 844.33	\$ 827.27
71	\$ 906.00	\$ 902.94	\$ 900.97	\$ 887.17	\$ 876.32	\$ 855.29	\$ 844.04	\$ 826.63
72	\$ 907.00	\$ 903.91	\$ 901.92	\$ 887.96	\$ 876.99	\$ 855.74	\$ 844.37	\$ 826.78
73	\$ 908.00	\$ 904.87	\$ 902.86	\$ 888.75	\$ 877.66	\$ 856.19	\$ 844.70	\$ 826.94
74	\$ 909.00	\$ 905.84	\$ 903.80	\$ 889.54	\$ 878.33	\$ 856.63	\$ 845.03	\$ 827.09
75	\$ 910.00	\$ 906.80	\$ 904.74	\$ 890.33	\$ 879.00	\$ 857.08	\$ 845.35	\$ 827.24
76	\$ 911.00	\$ 907.77	\$ 905.69	\$ 891.12	\$ 879.67	\$ 862.24	\$ 845.68	\$ 827.38

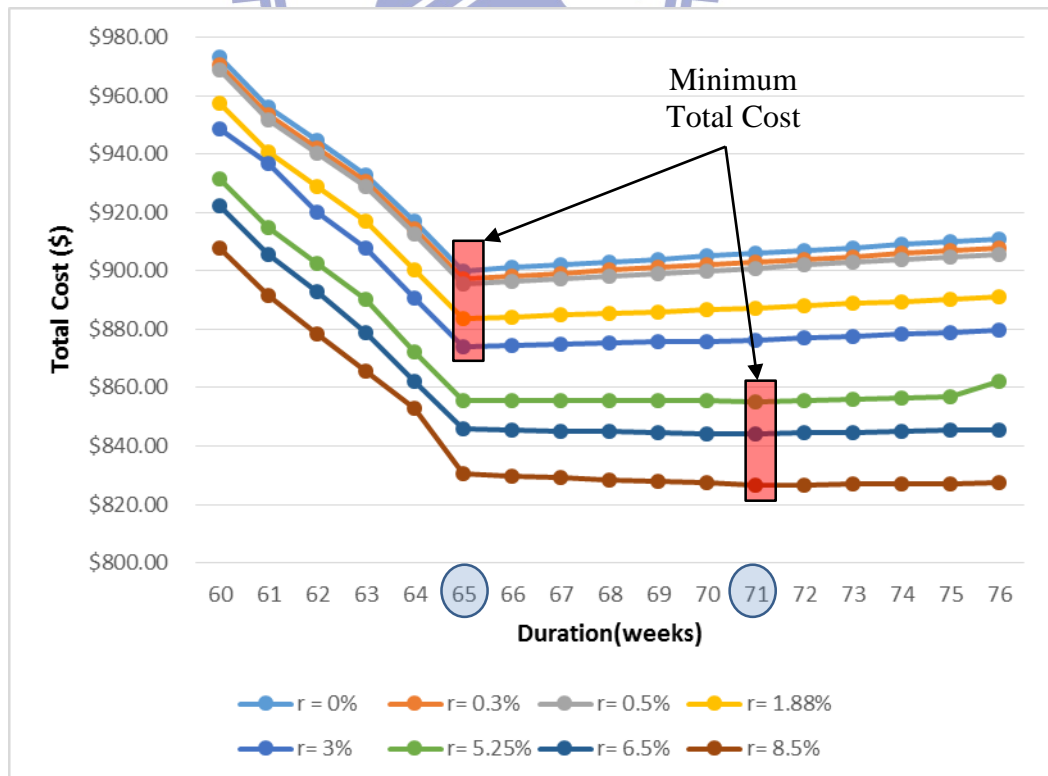

Figure 4.1. Total cost solutions for DCFs case with $r = 0.00\% - 8.5\%$.

Summary

From the obtained results, it is obvious that ignoring the time value of money in the analysis of the TCTO problem can produce incorrect decisions. The selected duration for activities and, consequently, the optimum project duration depend on the chosen interest rate value and the indirect cost rates. For the sample project on hand, the optimum project duration for DCFs exceeds that of ignoring the time value of money. This case problem example obtained 65 weeks as the optimal duration; however, when interest rates from 5.25% to 8.5% are used, 71 weeks is obtained as the optimal duration instead. This may not be the case for projects with different characteristics. One should therefore be careful in deciding the values of interest rate and of indirect cost.

4.2 TCTO with DCFs in Probabilistic Cost

Section 4.1 provides the optimum project duration with deterministic DCF at different interest rate. This section describes the optimization with probabilistic DCF at different rates.

4.2.1 Optimization with simulation results analysis







As described in Chapter 3, four experiments were conducted to test the change of optimum total cost at different dispersion of probabilistic values while maintaining the same mean.

For brevity, the following presents the simulation result using @Risk software at interest rates of 0% and 5.25%. Note that 5.25% is the interest rate where the optimum duration changes from 65 weeks to 71 weeks at an interest rate of 5.25%. Table 4.2 shows the statistics of the simulation result when the optimum duration was set to 65 weeks (i.e., the deterministic optimum duration at interest rate of 0.00%) and 71 weeks (i.e., the deterministic optimum duration at interest rate of 5.25%)

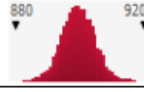
For example, at an optimal duration of 65 weeks, $r = 0.00\%$, simulation Experiment I has a 5th percentile value of \$892.5, 95th percentile value of

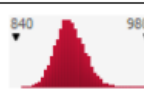
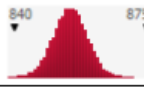
\$907.5, and standard deviation value of \$4.6 with a skewness value of 0.030, which means that this resulting distribution has a right-skewed distribution—most values are concentrated on the left of the mean, with extreme values to the right. Furthermore, it also has a kurtosis value of 2.96, which means that a kurtosis value greater than 3 can be categorized as a leptokurtic distribution, sharper than a normal distribution, with values concentrated around the mean and with thicker tails. This means a high probability for extreme values.

Table 4.2. Statistical simulation result of 65 weeks at 0.00% and 71 weeks at 5.25%.

Optimum duration	interest rates	No. Simulation	Graph	Min	Mean	Max	Std Dev	Variance	Skewness	Kurtosis	5%	95%
65	0.00%	#1		\$884.0	\$900.0	\$916.8	\$ 4.6	\$ 21.6	0.030535	2.9587	\$892.5	\$907.5
		#2		\$879.3	\$900.0	\$925.2	\$ 6.6	\$ 43.0	0.223446	3.0251	\$889.6	\$911.4
		#3		\$870.6	\$900.0	\$942.1	\$ 9.4	\$ 88.0	0.311252	3.0346	\$885.5	\$916.3
		#4		\$852.5	\$900.0	\$975.2	\$14.2	\$200.9	0.244667	3.1475	\$877.4	\$924.0
71	5.25%	#1		\$840.1	\$855.3	\$870.8	\$ 4.1	\$ 17.1	0.014223	3.0508	\$848.5	\$862.0
		#2		\$837.4	\$855.3	\$876.9	\$ 5.8	\$ 33.3	0.235941	2.977	\$846.2	\$865.4
		#3		\$830.4	\$855.3	\$892.4	\$ 8.3	\$ 69.3	0.345681	3.1008	\$842.4	\$870.0
		#4		\$814.8	\$855.3	\$912.9	\$12.6	\$159.7	0.22492	3.0625	\$835.3	\$876.6

Figures 4.3 and 4.4 show the result of simulation with parameter distribution type betageneral Experiment I (52.55, 78.83, 80%, 130%) in a box plot chart. Figure 4.5 shows that the optimal duration for $r = 0.00%$ is 65 weeks and that for $r = 5.25%$ is 71 weeks, based on their mean values. However, 67 weeks is its optimal duration at $r = 5.25%$ based on the 5th percentile value, and 71 weeks is its optimal duration based on the 95th percentile value.

Figure 4.5 plots minimum time-cost curves from simulation result of

Experiment I and shows the relation between project duration and the simulation output value of total project cost. It obviously shows that ignoring the time value of money in the simulation also gives incorrect optimal duration. Experiment I simulation may not have quite a high degree of uncertainty; therefore, probabilistic optimal duration is quite similar with deterministic optimal duration.

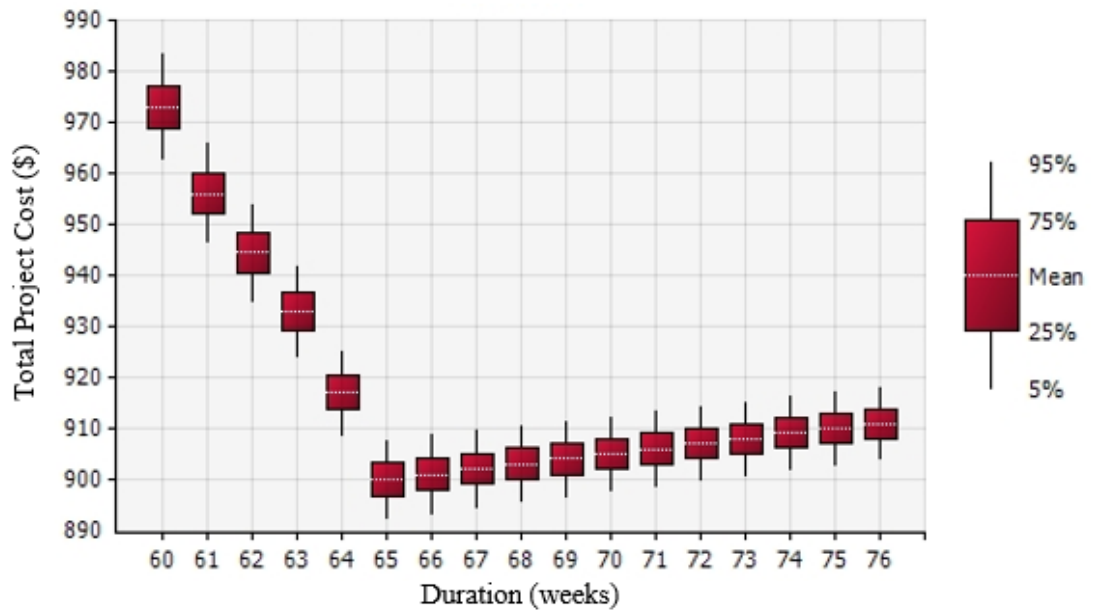

Figure 4.3. Time-cost box plot chart for the simulation results of Experiment I (52.55, 78.83, 80%, 130%) at $r = 0\%$.

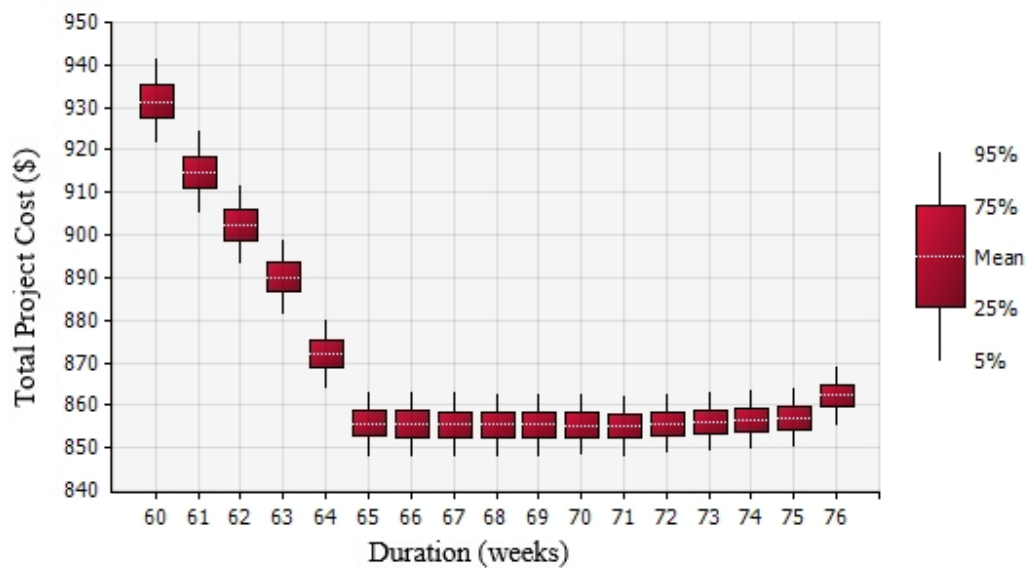

Figure 4.4. Time-cost box plot chart for the simulation results of Experiment I (52.55, 78.83, 80%, 130%) at $r = 5.25\%$.

Figure 4.6 shows the results of the simulation from Experiment II, which gives a higher degree of uncertainty of cost by enlarged probability distribution range but still keeps its mean value the same as the deterministic value. Although its optimal duration for the mean remained the same, 71 weeks, its resulting optimal duration for the 5th percentile simulation is 66 weeks, and the 95th percentile simulation results gave 70 weeks as its optimal duration. The detailed results of optimal values in the 5th and the 95th percentile simulation model nos. Experiment I, Experiment II, Experiment III, and Experiment IV can be seen in Table 4.2.

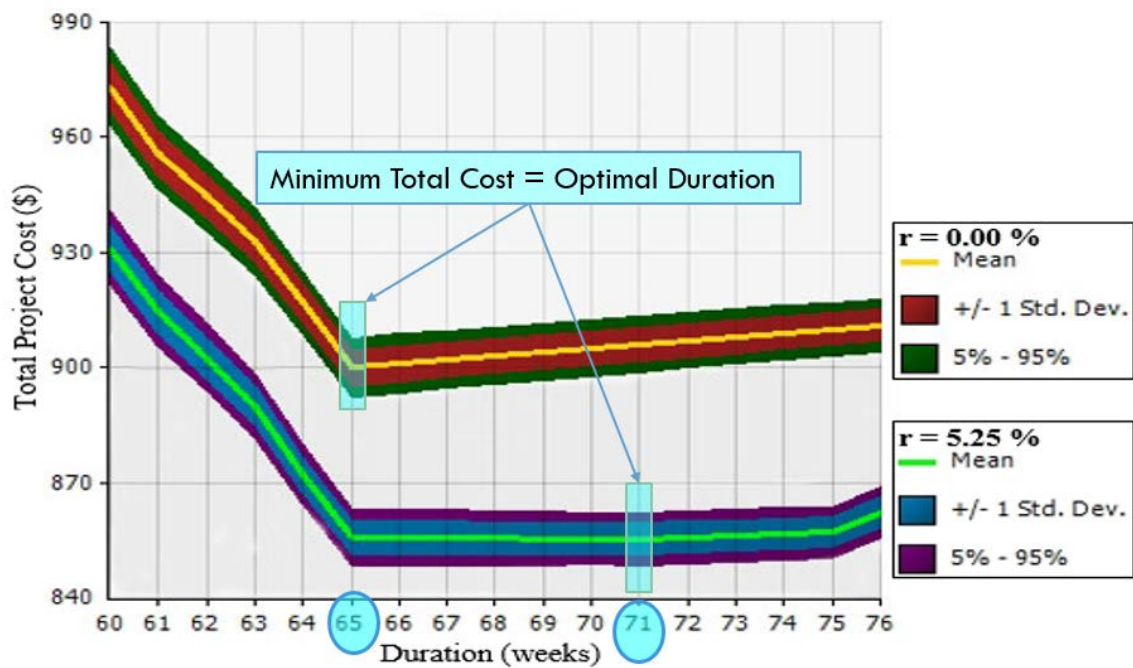

Figure 4.5. Time-cost curve of simulation results for Experiment I at $r = 0\%$ and $r = 5.25\%$.

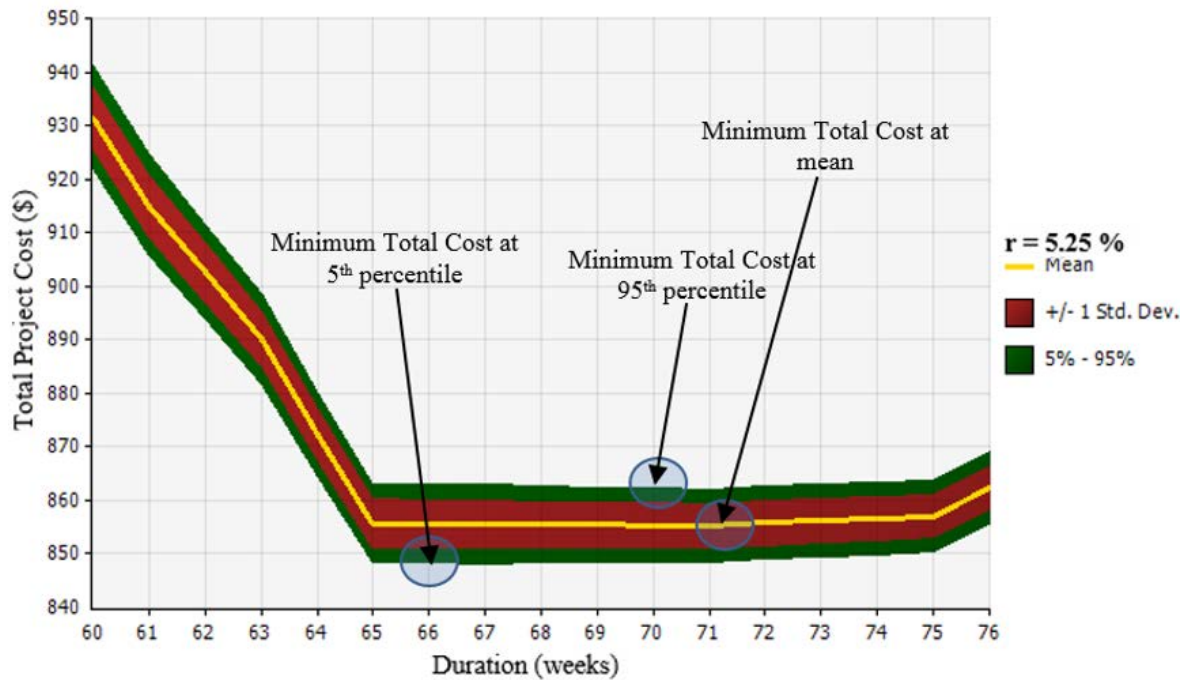

Figure 4.6. Time-cost curve of simulation results for Experiment II with $r = 5.25\%$.

Table 4.3 shows the optimal result of the simulation process for TCTO with DCFs. It shows the optimal duration and total project cost through various interest rates (0.0%–8.5%) and degrees of uncertainty for models of project cost (Experiment I, Experiment II, Experiment III, and Experiment IV). This table presents the simulation results at the 5th and the 95th percentile levels. Nevertheless, from this table, it could be analyzed that the resulting data obviously show how the different degrees of uncertainty could also produce different optimal solution durations of the TCTO problem. However, at lower interest rate values (0.0%–3.0%), the optimal duration remains the same as the optimal deterministic duration.

Compared with the deterministic result, table 4.3 shows the following:

1. If the cost variation is controlled within 50% as in experiment I, variation of interest rate up to 8.50% does not change the optimal solution.
2. If the cost variation is greater than or equal 80% as in experiment II, III, and IV, the variation of interest rate is equal or greater than 5.25%, it shows a distinct optimal duration with deterministic optimal duration.

The relation of duration–cost–interest rate in each simulation model is graphically illustrated in Figures 4.7, 4.8, 4.9, and 4.10. The graphs imply that adjusting the degree of uncertainty also affects optimal duration in the 5th and the 95th percentile analyses. However, since the value differences were slightly small, the impacts of interest rate parameter adjustment are not illustrated very clearly in the 3-D figures.

Table 4.3. Optimal solution of duration and total project cost at the 5th and the 95th percentile levels.

Experiment no	Percentile level	Optimal	Variation of interest rate							
			0.00%	0.30%	0.50%	1.88%	3.00%	5.25%	6.50%	8.50%
Original (Deterministic)		Total Cost	\$ 900.0	\$ 897.3	\$ 895.6	\$ 883.6	\$ 874.1	\$ 855.3	\$ 844.0	\$ 826.6
		Duration	65	65	65	65	65	65	71	71
Experiment I (Δ probability range 50%)	5th percentile	Total Cost	\$ 892.5	\$ 889.6	\$ 888.1	\$ 875.9	\$ 866.6	\$ 848.3	\$ 837.4	\$ 820.1
		Duration	65	65	65	65	65	65	71	71
	95th percentile	Total Cost	\$ 907.5	\$ 904.9	\$ 903.2	\$ 891.2	\$ 881.8	\$ 862.0	\$ 850.8	\$ 833.3
		Duration	65	65	65	65	65	71	71	71
Experiment II (Δ probability range 80%)	5th percentile	Total Cost	\$ 889.6	\$ 887.2	\$ 885.7	\$ 873.7	\$ 864.0	\$ 845.8	\$ 835.0	\$ 817.7
		Duration	65	65	65	65	65	66	71	71
	95th percentile	Total Cost	\$ 911.4	\$ 908.5	\$ 906.8	\$ 894.5	\$ 884.9	\$ 865.1	\$ 853.6	\$ 836.0
		Duration	65	65	65	65	65	70	71	72
Experiment III (Δ probability range 110%)	5th percentile	Total Cost	\$ 885.5	\$ 883.3	\$ 881.5	\$ 869.6	\$ 860.0	\$ 842.0	\$ 831.5	\$ 814.2
		Duration	65	65	65	65	65	66	70	71
	95th percentile	Total Cost	\$ 916.3	\$ 913.5	\$ 911.9	\$ 899.8	\$ 889.9	\$ 869.7	\$ 858.1	\$ 840.3
		Duration	65	65	65	65	65	72	71	71
Experiment IV (Δ probability range 170%)	5th percentile	Total Cost	\$ 877.4	\$ 874.9	\$ 873.5	\$ 861.7	\$ 852.2	\$ 834.4	\$ 824.2	\$ 807.7
		Duration	65	65	65	65	65	66	65	71
	95th percentile	Total Cost	\$ 924.0	\$ 921.8	\$ 919.8	\$ 907.9	\$ 897.7	\$ 876.6	\$ 865.6	\$ 847.4
		Duration	65	65	65	65	66	70	71	70

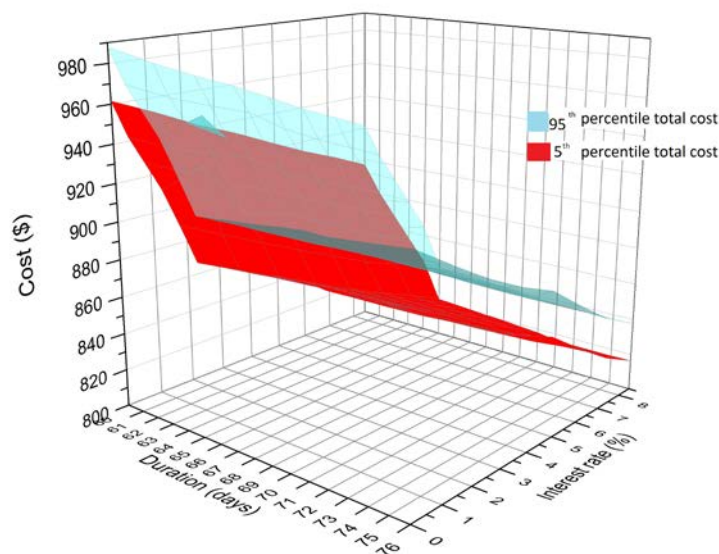

Figure 4.7. Graph of the cost–time–interest rate relationship Experiment I (52.55, 78.83, 80%, 130%).

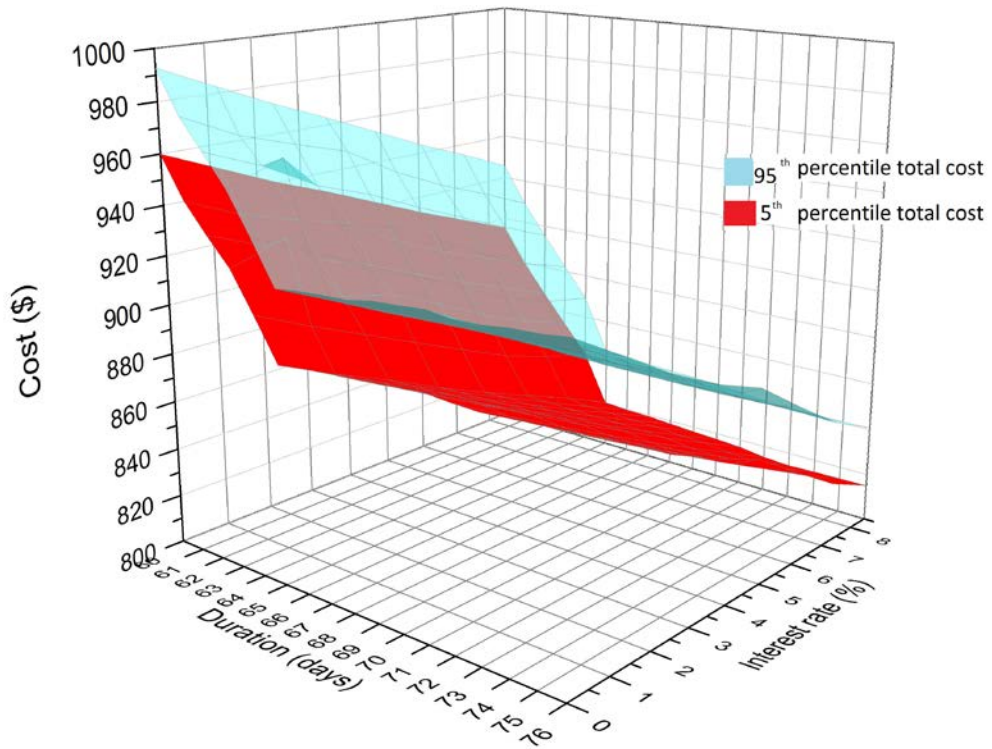

Figure 4.8. Graph of the cost–time–interest rate relationship Experiment II (9.86, 69.04, 90%, 170%).

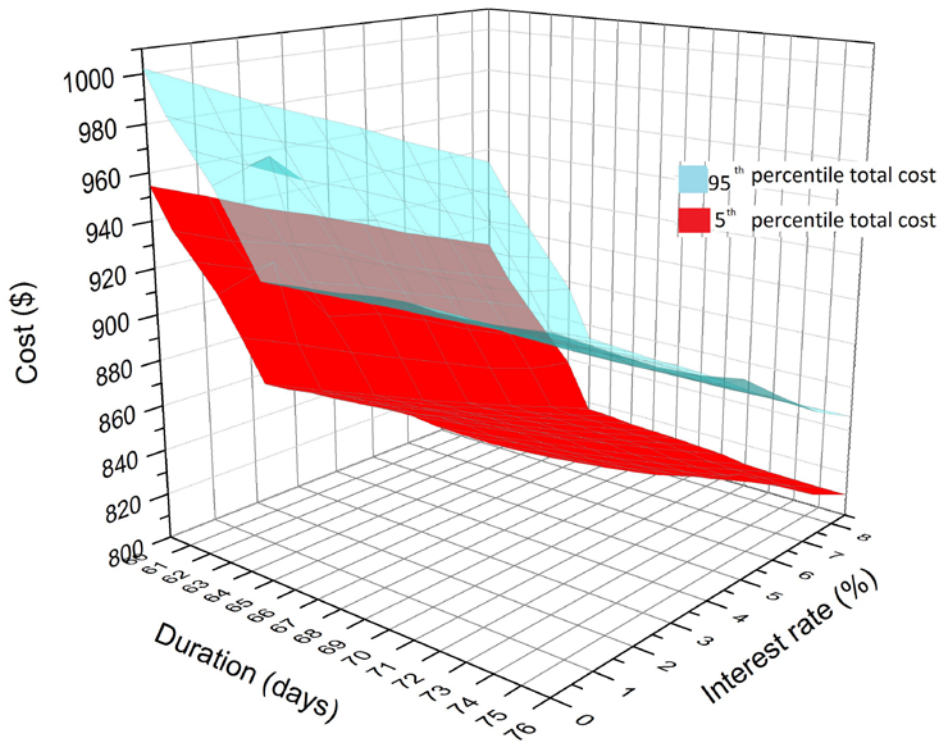

Figure 4.9. Graph of the cost–time–interest rate relationship Experiment III (5.01, 50.10, 90%, 200%).

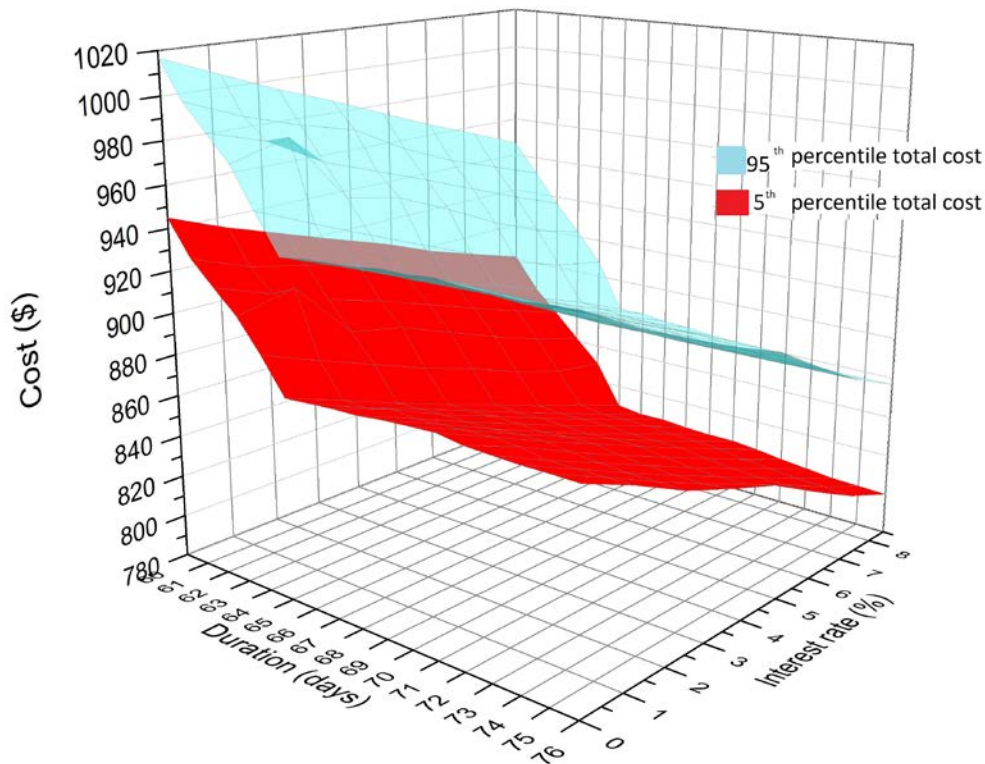

Figure 4.10. Graph of the cost–time–interest rate relationship Experiment IV(8.33, 62.49, 80%, 250%).

Summary

One can be obtained from this simulation; it is obvious that involving simulation in order to foresee uncertainty in the analysis of TCTO problem can show other possible decisions. The selected duration for activities and, consequently, the optimal project duration depend on the chosen interest rate value and the premium risk of a decision maker by adjusting its range of probability value.

The different risk profiles of a decision maker may choose different optimal durations from each other. For example, in this case, if the degree of uncertainty is quite high and the decision maker has a risk-averse risk profile, a 70-week duration is chosen as the optimal TCTO duration. However, if the decision maker is optimistic and has a risk-seeker risk profile, a 66-week duration is chosen instead. Therefore, when the degree of uncertainty in cost is quite high, involving a simulation process in TCTO will obviously give an

unforeseen optimal duration by assuming it to be a deterministic cost. However, it is necessary to involve DCFs and simulation in TCTO analysis when the interest rate is very low, for instance in some countries such as Japan, Switzerland, and Singapore, and when the degree of uncertainty is not really high as well.

4.2.2 Probabilistic Risk Assessment

Probabilistic risk assessment (PRA) uses probability distributions to characterize variability or uncertainty in risk estimates. In a PRA, one or more variables in the risk equation is defined as a probability distribution rather than a single number. Similarly, the output of a PRA is a range or probability distribution of risks experienced by the receptors. Note that the ability to perform a PRA often is limited by the availability of distributional data that adequately describe one or more of the input parameters.

The primary advantage of PRA is that it can provide a quantitative description of the degree of variability or uncertainty (or both) in risk estimates for total cost project in TCTO problem. The quantitative analysis of uncertainty and variability can provide a more comprehensive characterization of risk than is possible in the point estimate approach.

Another significant advantage of PRA is the additional information and potential flexibility it affords the risk manager. Risk management decisions are often based on an evaluation of high-end risk to an individual for deterministic analyses, this is generally developed by the combination of a mix of central tendency and high-end point values for various exposure parameters. When using PRA, the risk manager can select a specific upper-bound level from the high-end range of percentiles of risk, in this studies is 95th percentiles and 5th percentiles as the low-end range of percentiles of risk.

After finding the optimal solutions, several probabilistic analyses can be performed according to the project planner's needs. For example, the project planner may want to know the distributions of project cost for a certain solution.

The project planner can use simulation to find this. A simulation is performed by using the suggested “best options duration” presented in Table 3.4.

From the previous simulation, 65 weeks was obtained as optimal duration for interest rate 0.00% and 71 weeks were obtained as optimal duration for interest rate 5.25%; therefore this part takes 65 and 71 weeks to analyze probability risk assessment. Figure 4.11, 4.12, and 4.13 illustrate the probability density function (PDF) and cumulative distribution function (CDF) of the project cost at optimal duration, respectively.

We can estimate the project cost for this example by using the mean value. In addition, the project planner can look into the CDF of the project duration to find out the probability that the project can be finished within a certain desired cost and degree of uncertainty.

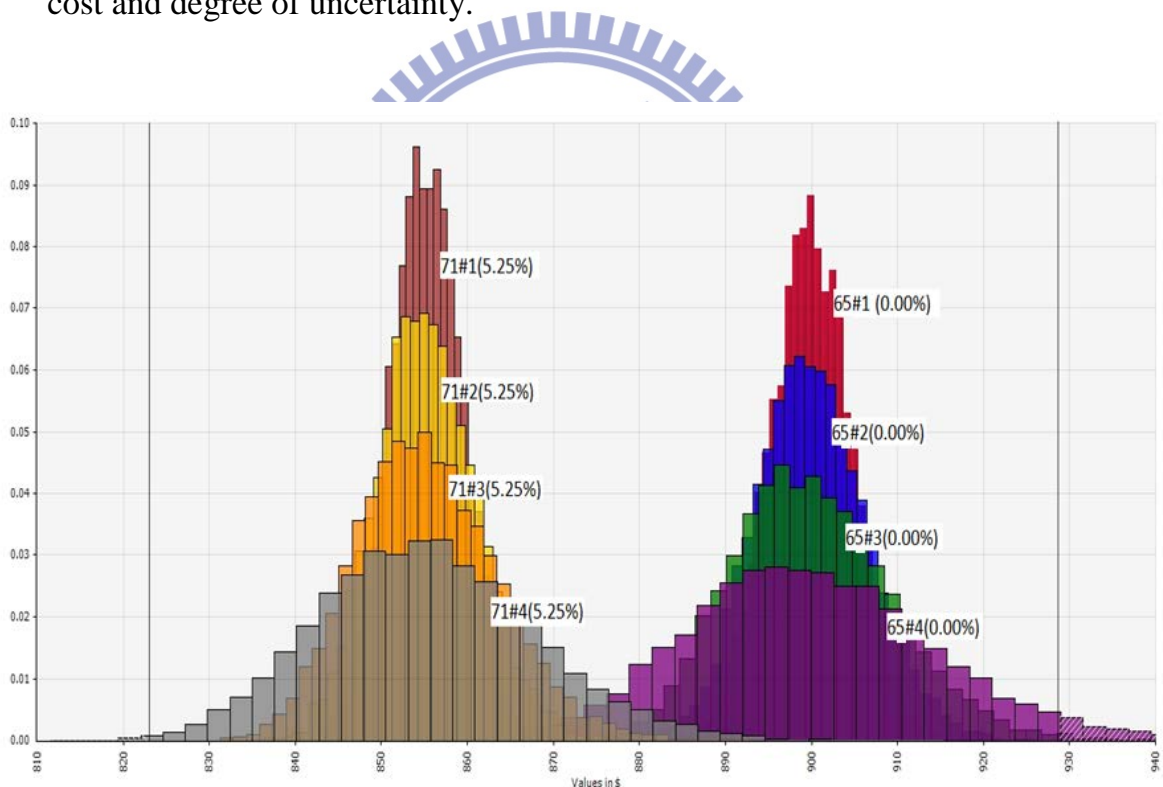

Figure 4.11 Probability density function of total project cost Experiment I at duration 65 weeks ($r = 0.00\%$) and duration 71 weeks($r = 5.25\%$)

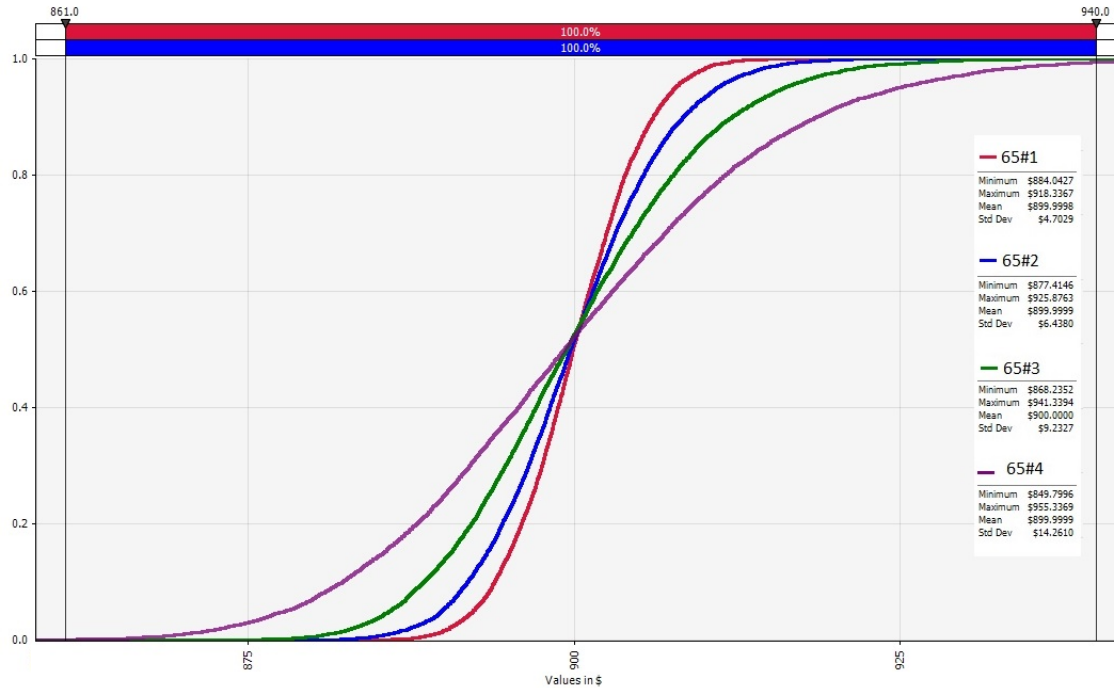

Figure 4.12 Cumulative distribution function of total project cost
Experiment I at duration 65 weeks at $r = 0.00\%$

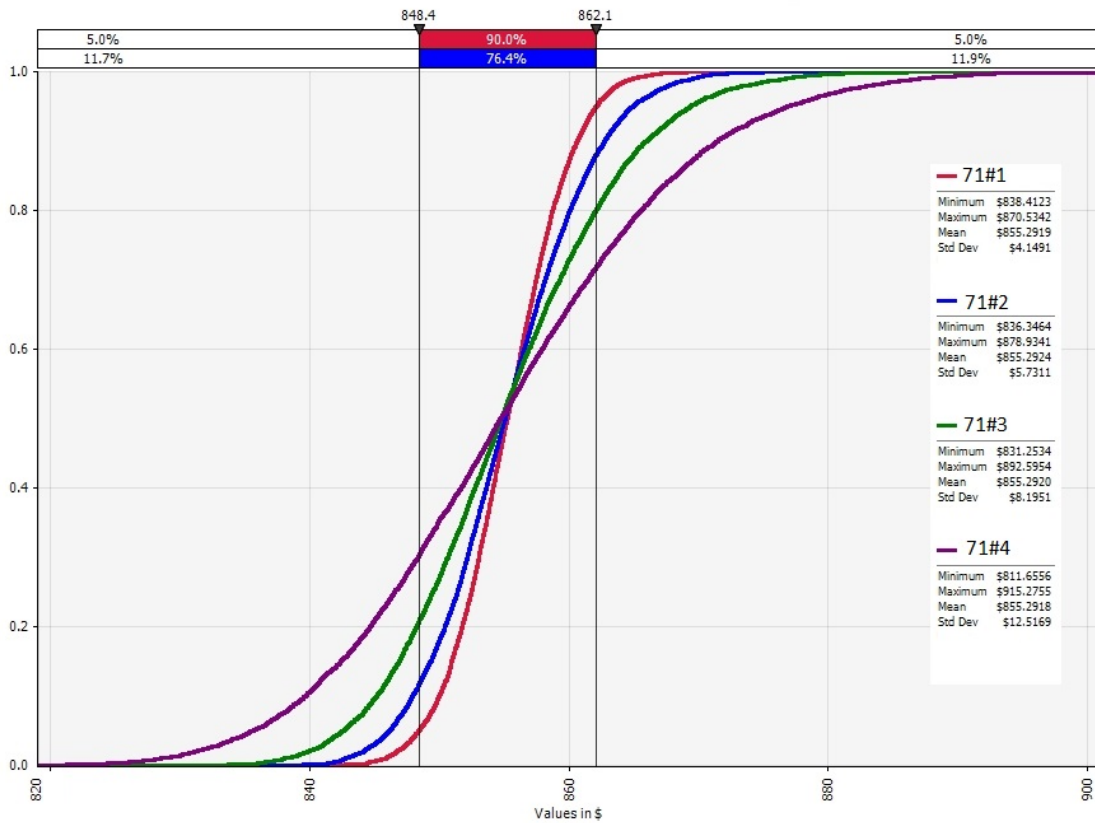

Figure 4.13 Cumulative distribution function of total project cost
Experiment I at duration 71 weeks at $r = 5.25\%$

The result according to 4.13 for 71 weeks Experiment I could be interpretable as follows:

1. The mean figure for total cost at this optimal duration will be \$855.29.
2. The minimum figure for total cost at this optimal duration will be \$ 838.41, but this figure is the bottom line and will only be achieved if all positive circumstances would occur. Therefore the implementation of Value at Risk (VaR) is necessary. The result for VaR 5% is \$ 848.47. That means with a probability of 5 %, the figure for total cost at this optimal duration will not exceed \$ 848.47. Or in other words: with a probability of 95 % the figure for total cost will exceed \$ 848.47.
3. The maximum figure for total cost at this optimal duration will be \$870.53. However, this figure is the upper limit and will only be achieved if all negative circumstances would occur. Therefore the implementation of Value at Risk (VaR) is also necessary under this point of view. The result for VaR 95% is \$862.02. That means with a probability of 95 %, the figure for total cost at this optimal duration will not exceed \$862.02. Or in other words: only with a probability of 5 % the figure for total cost at this optimal duration will exceed \$862.02.

Figure 4.11 and 4.12 show the PDF and CDF of the project cost with four types of degree uncertainty, respectively. For example, if the desired duration is 71 days, interest rate 5.25%, degree uncertainty betageneral Experiment II at cost \$860, the probability would be around 79.6%.

Summary

Using a probabilistic approach to arrive at optimum project duration not only makes better use of the available historical data (if available) or risk profile, but it also provides additional information to facilitate the planning process associated to the reduction of a project schedule. Being able to doing PDA is one of the most important

advantages from the simulation process. A decision-maker can obtain the optimal duration at various percentile levels of the risk results. Nevertheless, by more complete provided information for uncertainty, cost also helps the decision-maker of the project to solving TCTO with DCFs under uncertainty cost condition; therefore, incorrect optimal duration can be avoided.

Managing risks in construction projects has been recognized as a very important management process in order to achieve the project objectives in terms of time, cost, quality, safety and environmental sustainability. The uncertainty of the cost project depends on the risk factor projects. Furthermore, the probability range of uncertainty cost is identified based on cost planner's risk analysis. Table 4.4 shows the risk factors of the construction project that influence in identification of the range probability.

Table 4.4 Risk factor of construction project (Karim, 2012)

Risk Category	Risk factor
Construction	Land acquisition
	Shortage of equipment
	Shortage of material
	Late deliveries of material
	Poor quality of workmanship
	Site safety
	Insolvency of subcontractors
	Inadequate planning
	Weather
	Insolvency of suppliers
Politics & Contract Provision	Change in law and regulation
	Delay in project approval and permit
	Inconsistencies in government policies
	Excessive contract variation
	Poor supervision
	Bureaucracy
Finance	Delay in payment for claim
	Cash flow difficulties
	Lack of financial resources
Design	Improper design
	Change of scope
Environmental	Pollution
	Ecological damage
	Compliance with law and regulation for environmental issue

CHAPTER 5

CONCLUSION

5.1 Conclusion

Most of the time-cost trade-off (TCTO) analysis in construction management has disregarded a time value of money. From the results obtained, it was obvious that ignoring a time value of money in the analysis of TCTO problem could produce incorrect decisions. The proposed approach can help the practitioners in considering net present value in time-cost decisions leading to identification of the best option. It can be concluded that Discounted Cash Flows (DCFSS) should be considered during the analysis of TCTO problem, especially for projects span over time periods more than one year. TCTO analysis with DCFs produces realistic results and consequently, sound decisions. The proposed approach can help the practitioners in considering net present value in time-cost decisions leading to identification of the best option. It can be concluded that DCF should be considered in the analysis of TCTO problem, especially for projects span over time periods more than one year rather than projects span less than one year that is not effective to be considered. TCTO analysis with DCF produces realistic results and consequently sound decisions.

This research utilizes simulation techniques to imitate the probabilistic nature of project networks throughout the search of optimal solutions. This approach provides more realistic solutions for construction time-cost trade-off problem under uncertainty. An example project from the literature is used to demonstrate the usefulness of the model and to illustrate its capabilities. The model has the following features: (1) optimum solution is guaranteed; (2) precise discrete activity time-cost relationship is used; (3) time value of money is taken into consideration; and (4) uncertainty in the project also are involved. The results show that inclusion of discounted cash flow results in distinct optimal project duration. Nevertheless, through the Monte Carlo simulation, which is in

order to involve uncertainty, this proposed model also lead to distinct optimal duration at the certain percentile level. It also demonstrates that risk analysis techniques such as probabilistic risk assessments that can provide more unforeseen probability risk of assessing project time and cost risks in TCTO problem. This approach provides construction engineers with a new way of analyzing construction time/cost decisions in a more realistic manner with considering a time value of money and degree of uncertainty. The proposed model for this study can help the practitioners in considering time value of money and uncertainty cost, in order to make the best time-cost decision and to identify risks involved.

5.2 Recommendation for future research

A computational optimization model has been developed, which links the CPM with least-cost optimization, DCFs techniques and uncertainty cost in order to optimize the traditional Time-Cost Trade-Off problem. Although the main theme of proposed model is to account for DCFs, effect of inflation can be incorporated in further studies. Moreover, the stochastic interest rate model can also be incorporated in further studies. The model can be extended to handle other related features such as quality and environmental issues. Furthermore, the model can be automated and linked with commercial packages for ease problem handling.

REFERENCES

- Aladini, K., Afshar, A., & Kalhor, E. (2011). Discounted Cash Flow Time-Cost Trade-Off Problem Optimization; ACO Approach. *Asian Journal Of Civil Engineering*, 12(4), 511-522.
- Ammar, M. (2005). Discussion of 'Flexible model for time/cost tradeoff problem' by John Moussourakis and Cengiz Haksever. *J. Constr.Eng. Manage.*, 131(8), 942.
- Ammar, M. (2010). Optimization of project time-cost trade-off problem with discounted cash flows. *J. Constr.Eng. Manage.*, 137(1), 65-71.
- Eldosouky, A., Abdelreheem, A., & Ammar, M. (1991). An optimization approach to project cost/time problem., (pp. Pt. V, V61-V72.).
- Feng, C., Liu, L., & Burns, S. (1997). Using Genetic Algorithms to Solve Construction Time-Cost Trade-Off Problems. *J. Comput. Civ. Eng.*, 11(3), 184-189.
- Fondahl, J. (1961). *A non-computer approach to the critical path method for the construction industry*. The Construction Institute, Dept. of Civil Engineering. Stanford, Calif: Stanford Univ.
- Goldberg, D. E. (1989). Genetic algorithms in search, optimization and machine learning.
- Harris, R. B. (1978). *Precedence and Arrow Networking Techniques for Construction*. New York: Wiley.
- Holland, J. H. (1975). Adaptation in natural and artificial systems. *Univ. of Michigan Press*.
- Karim, N. A., Memmon, I. A., & Jamil, N. (2012). Significant Risk Factors in Construction Projects:Contractor's Perception. *IEEE Colloquium on Humanities, Science and Engineering Research (CHUSER)*.
- Liu, L., Burns, S., & Feng, C. (1995). Construction Time-Cost Trade-Off Analysis Using LP/IP Hybrid Method. *J. Constr.Eng. Manage.*, 121(4), 446-454.
- Moselhi, O. (1993). Schedule compression using the direct stiffness method. *Canadian Journal of Civil Engineering*, 20, 65-72.
- Palisade. (2009). *Guide to using @Risk: Risk Analysis and Simulation Add-In for Microsoft® Excel* (Vol. 5.5). Palisade Corporation.
- Palisade. (2009). *Guide to using Evolver: The Genetic Algorithm Solver for Microsoft Excel* (5.5 ed.). Palisade Corporation.
- Siemens, N. (1971). A simple CPM time-cost tradeoff algorithm. *Management Science*, 17(6), 354-363.
- Tareghian, H., & Taheri, S. (2006). On the discrete time, cost and quality trade-off problem. *Appl. Math. Comput.*, 181, 1305-1312.
- White, J., Case, K., Pratt, D., & Agee, M. (1998). *Principles of engineering economic analysis* (4 ed.). New York: Wiley.
- Zheng, D., Ng, S., & Kumaraswamy, M. (2004). Applying a Genetic Algorithm-Based Multiobjective Approach for Time-Cost Optimization. *J. Constr. Eng. Manage.*, 130(2), 168-176.

APPENDIX A: SIMULATION OUTPUT RESULT

I. Simulation output result for BetaGeneral Experiment I (52.55, 78.83, 80%, 130%)

Duration	r	Graph	Min	Mean	Max	Std Dev	Skewness	Kurtosis	5%	80%	90%	95%
60	0.00%		\$943.2	\$973.0	\$ 996.2	\$ 6.1	0.058	3.053	\$962.9	\$978.2	\$980.9	\$983.2
60	0.30%		\$948.5	\$970.5	\$ 998.2	\$ 6.0	0.068	3.042	\$960.6	\$975.6	\$978.3	\$980.4
60	0.50%		\$947.2	\$968.8	\$ 989.4	\$ 6.1	0.012	2.880	\$958.9	\$974.0	\$976.7	\$979.0
60	1.88%		\$933.4	\$957.6	\$ 981.6	\$ 6.0	0.003	2.988	\$947.7	\$962.7	\$965.3	\$967.5
60	3.00%		\$924.8	\$948.7	\$ 970.8	\$ 6.0	0.032	3.014	\$938.9	\$953.7	\$956.5	\$958.7
60	5.25%		\$908.8	\$931.4	\$ 954.2	\$ 5.9	0.067	3.037	\$921.9	\$936.3	\$939.0	\$941.1
60	6.50%		\$901.3	\$922.1	\$ 945.7	\$ 5.9	0.100	2.949	\$912.6	\$927.0	\$929.7	\$931.9
60	8.50%		\$888.8	\$907.7	\$ 931.0	\$ 5.8	0.030	2.987	\$898.1	\$912.5	\$915.1	\$917.2
61	0.00%		\$934.9	\$956.0	\$ 980.0	\$ 5.8	0.043	2.948	\$946.5	\$960.9	\$963.7	\$965.7
61	0.30%		\$933.3	\$953.5	\$ 976.0	\$ 5.9	0.082	2.944	\$944.0	\$958.4	\$961.1	\$963.4
61	0.50%		\$931.5	\$951.9	\$ 972.4	\$ 5.8	-0.009	2.889	\$942.3	\$956.9	\$959.4	\$961.5
61	1.88%		\$919.8	\$940.8	\$ 961.1	\$ 5.8	0.057	2.967	\$931.4	\$945.7	\$948.2	\$950.4
61	3.00%		\$916.3	\$936.7	\$ 957.9	\$ 5.6	0.021	2.971	\$927.5	\$941.5	\$943.9	\$946.1
61	5.25%		\$895.4	\$914.8	\$ 937.1	\$ 5.7	0.124	3.025	\$905.6	\$919.6	\$922.3	\$924.5
61	6.50%		\$882.3	\$905.6	\$ 928.9	\$ 5.6	0.029	3.024	\$896.5	\$910.4	\$912.8	\$914.9
61	8.50%		\$872.8	\$891.3	\$ 913.3	\$ 5.6	0.051	2.936	\$882.2	\$896.1	\$898.6	\$900.7
62	0.00%		\$925.7	\$944.5	\$ 965.4	\$ 5.6	0.037	2.911	\$935.2	\$949.3	\$951.8	\$953.8
62	0.30%		\$921.2	\$942.0	\$ 965.6	\$ 5.5	0.051	3.033	\$933.0	\$946.6	\$949.1	\$951.1
62	0.50%		\$916.2	\$940.3	\$ 960.2	\$ 5.6	0.042	3.006	\$931.2	\$945.0	\$947.5	\$949.4
62	1.88%		\$906.4	\$928.9	\$ 951.3	\$ 5.6	0.041	3.004	\$919.8	\$933.6	\$936.1	\$938.2
62	3.00%		\$898.8	\$919.9	\$ 943.0	\$ 5.5	0.037	3.036	\$911.1	\$924.6	\$926.9	\$929.1
62	5.25%		\$884.1	\$902.4	\$ 925.6	\$ 5.4	0.059	2.956	\$893.7	\$907.0	\$909.5	\$911.4
62	6.50%		\$873.8	\$893.1	\$ 912.9	\$ 5.3	0.049	3.043	\$884.4	\$897.5	\$899.8	\$901.8
62	8.50%		\$858.4	\$878.5	\$ 896.2	\$ 5.3	0.053	2.970	\$869.8	\$882.9	\$885.4	\$887.2

63	0.00%		\$911.9	\$933.0	\$ 952.5	\$ 5.4	0.054	2.989	\$924.3	\$937.6	\$939.9	\$941.8
63	0.30%		\$910.6	\$930.4	\$ 953.8	\$ 5.4	0.069	3.044	\$921.7	\$935.0	\$937.2	\$939.3
63	0.50%		\$909.6	\$928.7	\$ 950.2	\$ 5.2	0.061	3.045	\$920.2	\$933.1	\$935.5	\$937.5
63	1.88%		\$897.5	\$917.1	\$ 938.2	\$ 5.2	0.050	2.940	\$908.6	\$921.6	\$923.9	\$925.7
63	3.00%		\$889.0	\$907.9	\$ 928.4	\$ 5.3	0.032	3.029	\$899.3	\$912.3	\$914.7	\$916.6
63	5.25%		\$869.8	\$890.1	\$ 916.3	\$ 5.1	0.034	3.084	\$881.7	\$894.4	\$896.6	\$898.6
63	6.50%		\$861.0	\$878.6	\$ 896.1	\$ 4.9	0.028	2.997	\$870.6	\$882.7	\$884.9	\$886.8
63	8.50%		\$845.9	\$865.7	\$ 883.8	\$ 5.0	-0.014	2.954	\$857.3	\$869.9	\$872.2	\$873.9
64	0.00%		\$899.0	\$917.0	\$ 938.0	\$ 4.9	0.020	2.987	\$908.8	\$921.2	\$923.4	\$925.1
64	0.30%		\$896.0	\$914.3	\$ 932.7	\$ 5.0	0.064	2.986	\$906.2	\$918.5	\$920.7	\$922.5
64	0.50%		\$895.6	\$912.5	\$ 931.4	\$ 4.9	0.037	3.009	\$904.4	\$916.6	\$918.8	\$920.7
64	1.88%		\$879.0	\$900.4	\$ 921.0	\$ 4.9	-0.012	3.052	\$892.3	\$904.5	\$906.6	\$908.4
64	3.00%		\$870.5	\$890.8	\$ 910.1	\$ 4.8	0.028	3.033	\$882.8	\$894.9	\$897.0	\$898.8
64	5.25%		\$855.1	\$872.2	\$ 891.3	\$ 4.7	0.048	2.969	\$864.4	\$876.2	\$878.3	\$880.0
64	6.50%		\$845.0	\$862.2	\$ 879.1	\$ 4.7	0.033	2.969	\$854.6	\$866.1	\$868.2	\$870.0
64	8.50%		\$836.0	\$852.9	\$ 870.0	\$ 4.8	0.057	2.959	\$845.1	\$856.9	\$859.1	\$860.8
65	0.00%		\$884.0	\$900.0	\$ 916.8	\$ 4.6	0.031	2.959	\$892.5	\$904.0	\$906.0	\$907.5
65	0.30%		\$881.2	\$897.3	\$ 913.0	\$ 4.6	0.002	2.977	\$889.6	\$901.2	\$903.3	\$904.9
65	0.50%		\$877.3	\$895.6	\$ 913.0	\$ 4.6	0.023	2.967	\$888.1	\$899.4	\$901.5	\$903.2
65	1.88%		\$862.1	\$883.6	\$ 902.1	\$ 4.7	0.043	3.033	\$875.9	\$887.5	\$889.5	\$891.2
65	3.00%		\$858.5	\$874.1	\$ 890.6	\$ 4.6	0.039	2.952	\$866.6	\$878.0	\$879.9	\$881.8
65	5.25%		\$839.3	\$855.7	\$ 874.7	\$ 4.5	0.038	3.010	\$848.4	\$859.4	\$861.4	\$863.1
65	6.50%		\$829.9	\$845.8	\$ 864.7	\$ 4.4	0.031	3.013	\$838.6	\$849.5	\$851.5	\$853.1
65	8.50%		\$816.1	\$830.5	\$ 849.9	\$ 4.4	0.052	3.010	\$823.2	\$834.2	\$836.1	\$837.7

66	10.00%		\$880.7	\$901.0	\$ 917.6	\$ 4.7	0.040	2.993	\$893.4	\$904.9	\$907.1	\$908.8
66	0.30%		\$879.2	\$898.3	\$ 914.5	\$ 4.7	0.043	2.907	\$890.7	\$902.3	\$904.2	\$906.1
66	10.50%		\$878.7	\$896.5	\$ 913.6	\$ 4.6	0.039	2.988	\$888.9	\$900.3	\$902.5	\$904.3
66	1.88%		\$868.2	\$884.2	\$ 899.4	\$ 4.6	0.034	2.853	\$876.8	\$888.1	\$890.0	\$891.8
66	13.00%		\$857.4	\$874.5	\$ 892.0	\$ 4.5	0.015	2.963	\$866.9	\$878.2	\$880.2	\$881.9
66	5.25%		\$838.4	\$855.6	\$ 873.0	\$ 4.4	0.045	2.975	\$848.3	\$859.3	\$861.3	\$863.0
66	16.50%		\$827.7	\$845.5	\$ 861.7	\$ 4.4	0.017	3.031	\$838.3	\$849.2	\$851.1	\$852.8
66	8.50%		\$812.8	\$829.8	\$ 845.6	\$ 4.3	0.026	3.010	\$822.7	\$833.5	\$835.4	\$837.0
67	10.00%		\$885.0	\$902.0	\$ 919.5	\$ 4.5	0.042	2.967	\$894.6	\$905.8	\$908.0	\$909.6
67	0.30%		\$878.0	\$899.2	\$ 917.5	\$ 4.6	0.020	3.071	\$891.7	\$903.1	\$905.2	\$906.7
67	10.50%		\$881.3	\$897.4	\$ 917.8	\$ 4.6	0.086	3.009	\$889.9	\$901.2	\$903.3	\$905.0
67	1.88%		\$867.3	\$884.8	\$ 906.8	\$ 4.5	0.077	3.055	\$877.5	\$888.6	\$890.6	\$892.3
67	13.00%		\$856.3	\$874.8	\$ 891.4	\$ 4.4	0.001	3.016	\$867.6	\$878.5	\$880.5	\$882.2
67	5.25%		\$839.0	\$855.5	\$ 874.1	\$ 4.4	0.039	2.907	\$848.3	\$859.3	\$861.2	\$862.9
67	16.50%		\$827.4	\$845.2	\$ 862.2	\$ 4.4	0.014	2.975	\$838.0	\$848.8	\$850.7	\$852.4
67	8.50%		\$814.4	\$829.2	\$ 845.8	\$ 4.3	0.001	2.963	\$822.2	\$832.8	\$834.6	\$836.2
68	10.00%		\$886.1	\$903.0	\$ 920.5	\$ 4.5	0.037	2.974	\$895.6	\$906.9	\$908.8	\$910.4
68	0.30%		\$879.3	\$900.1	\$ 918.5	\$ 4.5	0.030	2.978	\$892.7	\$904.0	\$906.0	\$907.6
68	10.50%		\$881.9	\$898.3	\$ 916.9	\$ 4.5	0.037	3.022	\$890.9	\$902.0	\$904.0	\$905.7
68	1.88%		\$871.6	\$885.4	\$ 902.6	\$ 4.4	0.043	2.965	\$878.1	\$889.1	\$891.2	\$892.7
68	13.00%		\$859.8	\$875.2	\$ 893.3	\$ 4.4	0.055	2.962	\$868.1	\$878.9	\$880.9	\$882.5
68	5.25%		\$841.1	\$855.5	\$ 871.5	\$ 4.3	0.016	2.913	\$848.4	\$859.1	\$861.1	\$862.6
68	16.50%		\$829.3	\$844.9	\$ 860.9	\$ 4.3	0.049	3.003	\$838.0	\$848.5	\$850.3	\$852.0
68	8.50%		\$812.7	\$828.5	\$ 844.2	\$ 4.2	0.045	2.977	\$821.6	\$832.1	\$834.0	\$835.4

69	10.00%		\$886.7	\$904.0	\$ 923.1	\$ 4.5	0.049	2.970	\$896.7	\$907.8	\$909.8	\$911.4
69	0.30%		\$884.4	\$901.1	\$ 918.6	\$ 4.5	0.060	3.016	\$893.9	\$904.8	\$906.7	\$908.4
69	10.50%		\$882.6	\$899.2	\$ 915.8	\$ 4.4	0.018	2.962	\$891.9	\$902.9	\$904.8	\$906.5
69	1.88%		\$867.0	\$886.0	\$ 905.5	\$ 4.4	0.012	2.985	\$878.8	\$889.7	\$891.5	\$893.1
69	13.00%		\$859.8	\$875.6	\$ 892.2	\$ 4.4	-0.025	2.955	\$868.3	\$879.3	\$881.1	\$882.6
69	5.25%		\$841.5	\$855.4	\$ 871.5	\$ 4.3	0.022	2.850	\$848.5	\$859.0	\$860.9	\$862.5
69	16.50%		\$830.4	\$844.6	\$ 859.6	\$ 4.2	0.030	2.952	\$837.7	\$848.3	\$850.1	\$851.6
69	8.50%		\$812.2	\$827.9	\$ 842.2	\$ 4.1	0.049	2.943	\$821.2	\$831.4	\$833.3	\$834.8
70	10.00%		\$889.0	\$905.0	\$ 922.7	\$ 4.4	0.042	3.007	\$897.9	\$908.6	\$910.6	\$912.2
70	0.30%		\$886.2	\$902.0	\$ 918.3	\$ 4.4	0.039	3.019	\$894.8	\$905.7	\$907.6	\$909.2
70	10.50%		\$882.8	\$900.1	\$ 916.4	\$ 4.3	0.041	2.987	\$893.0	\$903.7	\$905.6	\$907.2
70	1.88%		\$871.9	\$886.6	\$ 905.2	\$ 4.4	0.066	3.014	\$879.5	\$890.2	\$892.2	\$893.8
70	13.00%		\$859.2	\$875.9	\$ 895.0	\$ 4.3	0.040	3.084	\$869.0	\$879.5	\$881.5	\$882.9
70	5.25%		\$839.8	\$855.4	\$ 872.5	\$ 4.2	0.022	3.029	\$848.6	\$858.9	\$860.6	\$862.3
70	16.50%		\$828.3	\$844.3	\$ 861.2	\$ 4.1	0.036	3.034	\$837.7	\$847.8	\$849.6	\$851.0
70	8.50%		\$813.2	\$827.3	\$ 842.9	\$ 4.1	0.007	2.994	\$820.7	\$830.7	\$832.5	\$834.0
71	10.00%		\$891.4	\$906.0	\$ 921.4	\$ 4.4	0.054	2.885	\$898.9	\$909.7	\$911.7	\$913.3
71	0.30%		\$886.4	\$902.9	\$ 919.1	\$ 4.3	0.038	2.968	\$895.9	\$906.6	\$908.5	\$910.2
71	10.50%		\$883.1	\$901.0	\$ 915.9	\$ 4.3	0.008	2.956	\$894.1	\$904.6	\$906.4	\$908.0
71	1.88%		\$870.9	\$887.2	\$ 906.1	\$ 4.2	0.013	3.037	\$880.2	\$890.7	\$892.5	\$894.1
71	13.00%		\$859.4	\$876.3	\$ 890.6	\$ 4.2	0.061	2.941	\$869.4	\$879.9	\$881.8	\$883.4
71	5.25%		\$840.1	\$855.3	\$ 870.8	\$ 4.1	0.014	3.051	\$848.5	\$858.8	\$860.6	\$862.0
71	16.50%		\$828.3	\$844.0	\$ 860.7	\$ 4.1	0.049	2.946	\$837.4	\$847.5	\$849.3	\$850.8
71	8.50%		\$810.5	\$826.6	\$ 842.1	\$ 4.0	0.057	3.044	\$820.1	\$830.0	\$831.8	\$833.3

72	10.00%		\$891.2	\$907.0	\$ 925.3	\$ 4.3	0.066	3.042	\$900.1	\$910.6	\$912.5	\$914.0
72	0.30%		\$887.5	\$903.9	\$ 922.1	\$ 4.3	-0.012	3.000	\$896.8	\$907.5	\$909.4	\$910.9
72	10.50%		\$884.2	\$901.9	\$ 919.6	\$ 4.3	0.051	2.993	\$894.9	\$905.5	\$907.5	\$909.1
72	1.88%		\$872.5	\$888.0	\$ 903.3	\$ 4.2	0.079	3.000	\$881.1	\$891.5	\$893.4	\$895.0
72	13.00%		\$862.0	\$877.0	\$ 892.3	\$ 4.2	0.051	2.986	\$870.1	\$880.5	\$882.4	\$884.0
72	5.25%		\$841.1	\$855.7	\$ 872.8	\$ 4.1	0.056	2.981	\$849.0	\$859.2	\$861.0	\$862.7
72	16.50%		\$829.7	\$844.4	\$ 859.2	\$ 4.0	0.017	2.973	\$837.7	\$847.8	\$849.5	\$851.1
72	8.50%		\$811.7	\$826.8	\$ 841.6	\$ 4.0	0.033	2.933	\$820.4	\$830.1	\$831.9	\$833.4
73	10.00%		\$893.0	\$908.0	\$ 923.3	\$ 4.3	0.006	2.941	\$901.0	\$911.6	\$913.4	\$915.0
73	0.30%		\$887.2	\$904.9	\$ 920.6	\$ 4.3	0.049	3.002	\$897.8	\$908.5	\$910.4	\$912.1
73	10.50%		\$884.7	\$902.9	\$ 922.1	\$ 4.3	-0.012	2.977	\$895.9	\$906.5	\$908.3	\$909.8
73	1.88%		\$873.6	\$888.8	\$ 904.1	\$ 4.2	0.024	2.993	\$881.9	\$892.3	\$894.1	\$895.8
73	13.00%		\$861.2	\$877.7	\$ 892.1	\$ 4.2	0.038	2.994	\$870.9	\$881.1	\$883.0	\$884.6
73	5.25%		\$842.1	\$856.2	\$ 871.0	\$ 4.1	0.023	2.986	\$849.5	\$859.6	\$861.4	\$862.9
73	16.50%		\$827.4	\$844.7	\$ 859.8	\$ 4.0	0.017	2.975	\$838.0	\$848.0	\$849.9	\$851.3
73	8.50%		\$812.4	\$826.9	\$ 842.7	\$ 3.9	0.023	2.990	\$820.5	\$830.2	\$832.1	\$833.5
74	10.00%		\$891.3	\$909.0	\$ 925.1	\$ 4.2	0.029	2.992	\$902.1	\$912.6	\$914.4	\$916.1
74	0.30%		\$890.3	\$905.8	\$ 922.9	\$ 4.2	-0.001	2.982	\$898.9	\$909.4	\$911.3	\$912.8
74	10.50%		\$882.9	\$903.8	\$ 923.0	\$ 4.2	0.035	3.022	\$896.9	\$907.4	\$909.3	\$910.9
74	1.88%		\$872.2	\$889.5	\$ 905.6	\$ 4.2	0.064	3.044	\$882.7	\$893.0	\$894.8	\$896.5
74	13.00%		\$864.7	\$878.3	\$ 896.5	\$ 4.1	0.038	3.081	\$871.6	\$881.8	\$883.5	\$885.1
74	5.25%		\$842.5	\$856.6	\$ 872.8	\$ 4.0	0.083	2.960	\$850.0	\$860.0	\$861.8	\$863.5
74	16.50%		\$829.9	\$845.0	\$ 860.9	\$ 4.0	0.022	3.037	\$838.5	\$848.5	\$850.2	\$851.6
74	8.50%		\$813.1	\$827.1	\$ 842.4	\$ 4.0	0.043	2.976	\$820.6	\$830.5	\$832.2	\$833.7

75	10.00%		\$894.1	\$910.0	\$ 925.8	\$ 4.2	0.032	3.062	\$903.1	\$913.5	\$915.4	\$916.9
75	0.30%		\$892.0	\$906.8	\$ 924.3	\$ 4.2	0.064	2.976	\$900.0	\$910.3	\$912.3	\$913.8
75	10.50%		\$888.5	\$904.7	\$ 922.8	\$ 4.2	0.022	2.920	\$897.9	\$908.3	\$910.2	\$911.6
75	1.88%		\$875.5	\$890.3	\$ 904.8	\$ 4.1	0.002	2.968	\$883.5	\$893.8	\$895.6	\$897.1
75	13.00%		\$863.9	\$879.0	\$ 894.0	\$ 4.1	0.045	2.993	\$872.2	\$882.5	\$884.4	\$885.7
75	5.25%		\$844.1	\$857.1	\$ 873.0	\$ 4.0	0.018	2.945	\$850.4	\$860.5	\$862.3	\$863.8
75	16.50%		\$829.3	\$845.4	\$ 860.1	\$ 4.0	0.048	2.978	\$838.9	\$848.7	\$850.5	\$852.0
75	8.50%		\$814.3	\$827.2	\$ 841.5	\$ 3.9	0.016	2.942	\$820.9	\$830.5	\$832.3	\$833.7
76	10.00%		\$895.7	\$911.0	\$ 926.0	\$ 4.2	0.030	2.943	\$904.1	\$914.6	\$916.4	\$917.8
76	0.30%		\$892.4	\$907.8	\$ 924.3	\$ 4.2	0.041	3.063	\$900.8	\$911.4	\$913.2	\$914.7
76	10.50%		\$890.0	\$905.7	\$ 921.5	\$ 4.1	0.060	2.977	\$898.9	\$909.2	\$911.1	\$912.6
76	1.88%		\$875.8	\$891.1	\$ 907.3	\$ 4.2	0.058	2.991	\$884.3	\$894.6	\$896.5	\$898.1
76	13.00%		\$864.8	\$879.7	\$ 894.9	\$ 4.1	0.019	2.911	\$873.0	\$883.1	\$884.9	\$886.4
76	5.25%		\$846.6	\$862.2	\$ 877.1	\$ 4.0	0.018	2.937	\$855.6	\$865.7	\$867.5	\$869.0
76	16.50%		\$830.8	\$845.7	\$ 861.2	\$ 4.0	0.007	2.957	\$839.2	\$849.0	\$850.7	\$852.2
76	8.50%		\$811.6	\$827.4	\$ 844.8	\$ 3.9	0.033	2.980	\$820.9	\$830.7	\$832.4	\$833.8

II. Simulation output result for BetaGeneral Experiment II(9.86, 69.04, 90%, 170%)

Duration	r	Graph	Min	Mean	Max	Std Dev	Skewness	Kurtosis	5%	80%	90%	95%
60	10.00%		\$945.9	\$973.0	\$ 1,011.8	\$ 8.3	0.319	3.124	\$960.1	\$979.9	\$983.9	\$987.5
60	0.30%		\$944.6	\$970.5	\$ 1,008.5	\$ 8.5	0.310	3.126	\$957.4	\$977.5	\$981.6	\$985.3
60	10.50%		\$937.3	\$968.8	\$ 1,009.3	\$ 8.4	0.302	3.154	\$955.7	\$975.8	\$979.9	\$983.4
60	1.88%		\$930.0	\$957.6	\$ 989.8	\$ 8.3	0.255	2.994	\$944.6	\$964.5	\$968.5	\$971.9
60	13.00%		\$922.8	\$948.7	\$ 984.0	\$ 8.2	0.320	3.123	\$936.1	\$955.5	\$959.6	\$962.9
60	5.25%		\$907.5	\$931.4	\$ 969.9	\$ 8.2	0.300	3.143	\$918.7	\$938.2	\$942.0	\$945.5
60	16.50%		\$895.2	\$922.1	\$ 957.5	\$ 8.2	0.278	3.112	\$909.4	\$928.8	\$932.7	\$936.1
60	8.50%		\$879.1	\$907.7	\$ 942.2	\$ 8.1	0.261	3.036	\$895.0	\$914.3	\$918.2	\$921.6

61	10.00%		\$929.6	\$956.0	\$ 988.5	\$ 8.2	0.294	3.068	\$943.2	\$962.8	\$966.8	\$970.2
61	0.30%		\$927.0	\$953.5	\$ 990.3	\$ 8.2	0.292	3.188	\$940.8	\$960.3	\$964.1	\$967.6
61	10.50%		\$923.4	\$951.9	\$ 991.8	\$ 8.1	0.331	3.271	\$939.6	\$958.5	\$962.4	\$966.0
61	1.88%		\$915.5	\$940.8	\$ 985.8	\$ 8.0	0.312	3.239	\$928.1	\$947.2	\$951.4	\$954.9
61	3.00%		\$910.5	\$936.7	\$ 973.2	\$ 7.8	0.278	3.086	\$924.4	\$943.2	\$947.0	\$950.1
61	5.25%		\$889.8	\$914.8	\$ 949.6	\$ 8.0	0.312	3.203	\$902.3	\$921.3	\$925.2	\$928.5
61	6.50%		\$878.8	\$905.6	\$ 942.3	\$ 7.9	0.330	3.189	\$893.3	\$912.1	\$916.1	\$919.2
61	8.50%		\$868.2	\$891.3	\$ 926.5	\$ 7.8	0.307	3.194	\$879.3	\$897.7	\$901.4	\$904.8
62	10.00%		\$920.7	\$944.5	\$ 984.0	\$ 7.8	0.295	3.181	\$932.3	\$950.8	\$954.6	\$957.8
62	0.30%		\$915.2	\$942.0	\$ 981.5	\$ 7.7	0.247	3.070	\$929.9	\$948.4	\$952.0	\$955.3
62	10.50%		\$915.5	\$940.3	\$ 978.3	\$ 7.7	0.275	3.069	\$928.3	\$946.7	\$950.5	\$953.6
62	1.88%		\$905.5	\$928.9	\$ 958.7	\$ 7.7	0.276	2.993	\$917.0	\$935.3	\$939.1	\$942.3
62	3.00%		\$896.2	\$919.9	\$ 955.3	\$ 7.6	0.298	3.185	\$908.1	\$926.2	\$930.0	\$933.1
62	5.25%		\$877.2	\$902.4	\$ 936.6	\$ 7.5	0.317	3.221	\$890.5	\$908.5	\$912.3	\$915.5
62	6.50%		\$870.7	\$893.1	\$ 924.9	\$ 7.5	0.301	3.089	\$881.4	\$899.2	\$902.9	\$906.0
62	8.50%		\$854.2	\$878.5	\$ 908.6	\$ 7.3	0.318	3.209	\$867.0	\$884.5	\$887.9	\$891.1
63	10.00%		\$907.9	\$933.0	\$ 969.2	\$ 7.4	0.258	3.081	\$921.4	\$939.1	\$942.6	\$945.7
63	0.30%		\$907.8	\$930.4	\$ 961.1	\$ 7.5	0.280	3.057	\$918.7	\$936.6	\$940.1	\$943.3
63	10.50%		\$905.9	\$928.7	\$ 962.3	\$ 7.3	0.269	3.047	\$917.3	\$934.8	\$938.3	\$941.2
63	1.88%		\$891.3	\$917.1	\$ 950.1	\$ 7.2	0.248	3.016	\$905.7	\$923.1	\$926.5	\$929.6
63	3.00%		\$884.5	\$907.9	\$ 937.7	\$ 7.3	0.243	3.067	\$896.5	\$913.9	\$917.6	\$920.4
63	5.25%		\$867.7	\$890.1	\$ 921.2	\$ 7.1	0.257	3.105	\$878.9	\$896.0	\$899.3	\$902.2
63	6.50%		\$853.5	\$878.6	\$ 904.2	\$ 6.8	0.222	3.033	\$867.9	\$884.4	\$887.7	\$890.4
63	8.50%		\$843.4	\$865.7	\$ 897.5	\$ 7.0	0.291	3.121	\$854.9	\$871.4	\$874.7	\$877.7

64	10.00%		\$894.3	\$917.0	\$ 944.5	\$ 6.9	0.244	3.061	\$906.2	\$922.7	\$926.1	\$928.9
64	0.30%		\$888.3	\$914.3	\$ 942.0	\$ 6.9	0.248	3.069	\$903.6	\$920.0	\$923.4	\$926.2
64	10.50%		\$890.7	\$912.5	\$ 941.3	\$ 6.8	0.218	3.012	\$901.8	\$918.2	\$921.4	\$924.4
64	1.88%		\$880.0	\$900.4	\$ 930.3	\$ 6.8	0.259	3.030	\$889.8	\$906.1	\$909.2	\$911.9
64	13.00%		\$867.7	\$890.8	\$ 919.3	\$ 6.8	0.166	3.031	\$880.0	\$896.5	\$899.6	\$902.2
64	5.25%		\$851.0	\$872.2	\$ 900.9	\$ 6.6	0.253	3.055	\$861.7	\$877.6	\$880.8	\$883.4
64	6.50%		\$837.2	\$862.2	\$ 888.1	\$ 6.6	0.240	3.058	\$851.8	\$867.7	\$870.7	\$873.5
64	8.50%		\$830.5	\$852.9	\$ 879.7	\$ 6.7	0.219	2.979	\$842.4	\$858.5	\$861.7	\$864.2
65	10.00%		\$878.8	\$900.0	\$ 925.0	\$ 6.6	0.250	3.014	\$889.7	\$905.5	\$908.6	\$911.3
65	0.30%		\$875.9	\$897.3	\$ 925.7	\$ 6.5	0.218	3.125	\$887.1	\$902.6	\$905.9	\$908.4
65	10.50%		\$876.7	\$895.6	\$ 928.7	\$ 6.5	0.288	3.073	\$885.4	\$901.0	\$904.2	\$906.8
65	1.88%		\$862.9	\$883.6	\$ 912.3	\$ 6.5	0.221	3.040	\$873.4	\$888.9	\$892.0	\$894.6
65	13.00%		\$852.9	\$874.1	\$ 900.8	\$ 6.4	0.245	3.026	\$864.1	\$879.4	\$882.4	\$885.0
65	5.25%		\$836.4	\$855.7	\$ 882.0	\$ 6.3	0.237	2.953	\$845.9	\$860.9	\$864.0	\$866.4
65	6.50%		\$823.7	\$845.8	\$ 876.0	\$ 6.2	0.264	3.167	\$836.1	\$850.9	\$853.8	\$856.5
65	8.50%		\$807.9	\$830.5	\$ 856.1	\$ 6.1	0.226	3.132	\$820.8	\$835.5	\$838.4	\$840.8
66	10.00%		\$882.1	\$901.0	\$ 933.7	\$ 6.5	0.255	3.140	\$890.9	\$906.3	\$909.4	\$912.1
66	0.30%		\$876.8	\$898.3	\$ 924.7	\$ 6.4	0.234	3.074	\$888.1	\$903.6	\$906.7	\$909.5
66	10.50%		\$873.5	\$896.5	\$ 932.0	\$ 6.5	0.242	3.150	\$886.3	\$901.8	\$905.0	\$907.5
66	1.88%		\$864.1	\$884.2	\$ 910.7	\$ 6.3	0.235	3.081	\$874.1	\$889.4	\$892.6	\$894.9
66	13.00%		\$854.7	\$874.5	\$ 900.6	\$ 6.3	0.238	3.137	\$864.6	\$879.6	\$882.6	\$885.1
66	5.25%		\$835.4	\$855.6	\$ 889.6	\$ 6.2	0.244	3.081	\$845.8	\$860.8	\$863.7	\$866.3
66	6.50%		\$826.3	\$845.5	\$ 870.6	\$ 6.1	0.246	2.988	\$835.9	\$850.6	\$853.6	\$856.1
66	8.50%		\$810.7	\$829.8	\$ 856.0	\$ 6.1	0.257	3.100	\$820.3	\$834.9	\$837.8	\$840.3

67	10.00%		\$880.5	\$902.0	\$ 932.2	\$ 6.3	0.262	3.186	\$892.1	\$907.2	\$910.2	\$912.9
67	0.30%		\$879.6	\$899.2	\$ 923.7	\$ 6.4	0.227	3.051	\$889.1	\$904.5	\$907.5	\$910.0
67	10.50%		\$876.5	\$897.4	\$ 930.9	\$ 6.2	0.222	3.126	\$887.4	\$902.6	\$905.5	\$907.9
67	1.88%		\$863.8	\$884.8	\$ 912.0	\$ 6.3	0.188	3.055	\$874.7	\$890.0	\$893.0	\$895.4
67	13.00%		\$855.4	\$874.8	\$ 901.2	\$ 6.2	0.233	3.015	\$865.0	\$880.0	\$883.0	\$885.5
67	5.25%		\$833.1	\$855.5	\$ 887.4	\$ 6.1	0.250	3.154	\$845.9	\$860.5	\$863.4	\$865.9
67	6.50%		\$825.5	\$845.2	\$ 871.7	\$ 6.0	0.217	3.106	\$835.6	\$850.1	\$853.1	\$855.5
67	8.50%		\$810.1	\$829.2	\$ 851.8	\$ 6.0	0.194	2.956	\$819.7	\$834.2	\$836.9	\$839.3
68	10.00%		\$882.8	\$903.0	\$ 934.1	\$ 6.3	0.260	2.993	\$893.3	\$908.3	\$911.3	\$913.7
68	0.30%		\$879.6	\$900.1	\$ 932.2	\$ 6.3	0.233	3.187	\$890.1	\$905.3	\$908.3	\$910.8
68	10.50%		\$879.4	\$898.3	\$ 921.3	\$ 6.2	0.211	2.996	\$888.5	\$903.4	\$906.4	\$908.9
68	1.88%		\$864.5	\$885.4	\$ 914.0	\$ 6.2	0.243	3.115	\$875.7	\$890.5	\$893.4	\$895.9
68	13.00%		\$854.6	\$875.2	\$ 901.7	\$ 6.1	0.205	3.052	\$865.7	\$880.3	\$883.2	\$885.6
68	5.25%		\$835.8	\$855.5	\$ 878.5	\$ 6.0	0.200	3.016	\$846.1	\$860.4	\$863.3	\$865.8
68	6.50%		\$820.4	\$844.9	\$ 869.2	\$ 5.9	0.214	3.019	\$835.5	\$849.9	\$852.6	\$855.1
68	8.50%		\$809.2	\$828.5	\$ 853.7	\$ 5.9	0.228	3.031	\$819.3	\$833.5	\$836.1	\$838.6
69	10.00%		\$884.1	\$904.0	\$ 937.0	\$ 6.2	0.224	3.038	\$894.2	\$909.2	\$912.1	\$914.6
69	0.30%		\$879.9	\$901.1	\$ 931.2	\$ 6.2	0.229	3.017	\$891.3	\$906.3	\$909.1	\$911.7
69	10.50%		\$880.6	\$899.2	\$ 924.8	\$ 6.1	0.224	3.038	\$889.5	\$904.3	\$907.1	\$909.8
69	1.88%		\$863.6	\$886.0	\$ 924.1	\$ 6.2	0.309	3.179	\$876.5	\$891.1	\$894.0	\$896.5
69	13.00%		\$857.4	\$875.6	\$ 899.8	\$ 6.0	0.264	3.053	\$866.3	\$880.5	\$883.5	\$885.8
69	5.25%		\$836.2	\$855.4	\$ 879.8	\$ 5.9	0.222	3.077	\$846.0	\$860.3	\$863.0	\$865.6
69	6.50%		\$823.9	\$844.6	\$ 870.4	\$ 5.9	0.198	3.028	\$835.3	\$849.5	\$852.3	\$854.5
69	8.50%		\$809.5	\$827.9	\$ 857.9	\$ 5.7	0.232	3.106	\$818.8	\$832.7	\$835.4	\$837.6

70	10.00%		\$885.0	\$905.0	\$ 931.1	\$ 6.1	0.260	3.096	\$895.4	\$910.0	\$913.0	\$915.5
70	0.30%		\$882.5	\$902.0	\$ 926.4	\$ 6.1	0.233	2.968	\$892.5	\$907.2	\$909.9	\$912.3
70	10.50%		\$880.7	\$900.1	\$ 926.4	\$ 6.0	0.211	3.087	\$890.5	\$905.0	\$907.8	\$910.4
70	1.88%		\$869.0	\$886.6	\$ 912.1	\$ 6.0	0.299	3.153	\$877.2	\$891.5	\$894.4	\$896.8
70	13.00%		\$856.8	\$875.9	\$ 901.6	\$ 6.0	0.215	2.976	\$866.3	\$881.0	\$883.9	\$886.3
70	5.25%		\$836.4	\$855.4	\$ 881.0	\$ 5.8	0.242	3.042	\$846.3	\$860.2	\$863.0	\$865.3
70	6.50%		\$823.2	\$844.3	\$ 868.4	\$ 5.7	0.203	3.048	\$835.2	\$849.0	\$851.7	\$854.1
70	8.50%		\$810.3	\$827.3	\$ 853.8	\$ 5.7	0.270	3.128	\$818.3	\$832.0	\$834.7	\$837.0
71	10.00%		\$886.0	\$906.0	\$ 932.7	\$ 6.1	0.247	3.073	\$896.5	\$911.1	\$914.0	\$916.4
71	0.30%		\$883.0	\$902.9	\$ 928.4	\$ 6.0	0.227	3.119	\$893.4	\$907.9	\$910.7	\$913.1
71	10.50%		\$882.3	\$901.0	\$ 926.4	\$ 6.0	0.258	3.103	\$891.6	\$905.8	\$908.8	\$911.3
71	1.88%		\$867.6	\$887.2	\$ 911.8	\$ 6.0	0.223	3.044	\$877.6	\$892.1	\$895.1	\$897.5
71	13.00%		\$857.0	\$876.3	\$ 905.7	\$ 5.9	0.239	3.258	\$867.0	\$881.1	\$883.9	\$886.4
71	5.25%		\$835.9	\$855.3	\$ 877.2	\$ 5.7	0.196	3.017	\$846.1	\$860.1	\$862.8	\$864.9
71	6.50%		\$826.0	\$844.0	\$ 867.1	\$ 5.7	0.255	3.030	\$834.9	\$848.8	\$851.6	\$853.9
71	8.50%		\$807.7	\$826.6	\$ 851.9	\$ 5.6	0.243	3.049	\$818.0	\$831.3	\$834.0	\$836.3
72	10.00%		\$888.6	\$907.0	\$ 934.2	\$ 6.0	0.233	3.073	\$897.5	\$911.9	\$914.9	\$917.4
72	0.30%		\$884.6	\$903.9	\$ 930.6	\$ 6.0	0.213	3.062	\$894.4	\$908.9	\$911.7	\$914.2
72	10.50%		\$882.4	\$901.9	\$ 925.4	\$ 5.9	0.198	3.022	\$892.6	\$906.8	\$909.6	\$912.0
72	1.88%		\$869.4	\$888.0	\$ 913.2	\$ 5.9	0.240	3.083	\$878.7	\$892.8	\$895.8	\$898.1
72	13.00%		\$857.6	\$877.0	\$ 905.2	\$ 5.9	0.231	3.167	\$867.6	\$881.9	\$884.5	\$886.9
72	5.25%		\$835.6	\$855.7	\$ 882.0	\$ 5.7	0.211	3.025	\$846.7	\$860.4	\$863.2	\$865.5
72	6.50%		\$824.8	\$844.4	\$ 865.9	\$ 5.6	0.225	3.020	\$835.5	\$849.0	\$851.8	\$854.1
72	8.50%		\$808.5	\$826.8	\$ 850.0	\$ 5.6	0.226	3.078	\$817.9	\$831.4	\$834.1	\$836.4

73	10.00%		\$885.6	\$908.0	\$ 930.4	\$ 5.9	0.212	3.004	\$898.7	\$912.9	\$915.8	\$918.3
73	0.30%		\$885.9	\$904.9	\$ 929.4	\$ 5.9	0.227	3.051	\$895.5	\$909.7	\$912.6	\$914.9
73	10.50%		\$883.3	\$902.9	\$ 930.8	\$ 6.0	0.224	3.063	\$893.4	\$907.9	\$910.6	\$913.0
73	1.88%		\$870.9	\$888.8	\$ 914.5	\$ 5.8	0.270	3.140	\$879.6	\$893.5	\$896.3	\$898.8
73	13.00%		\$858.4	\$877.7	\$ 905.7	\$ 5.8	0.221	3.038	\$868.5	\$882.5	\$885.3	\$887.5
73	5.25%		\$836.7	\$856.2	\$ 881.3	\$ 5.6	0.207	3.040	\$847.2	\$860.9	\$863.5	\$865.8
73	6.50%		\$825.9	\$844.7	\$ 867.5	\$ 5.5	0.208	3.043	\$836.0	\$849.2	\$852.0	\$854.3
73	8.50%		\$808.7	\$826.9	\$ 849.8	\$ 5.5	0.225	3.098	\$818.2	\$831.5	\$834.1	\$836.4
74	10.00%		\$886.7	\$909.0	\$ 932.1	\$ 5.9	0.217	3.013	\$899.8	\$913.9	\$916.7	\$919.1
74	0.30%		\$886.1	\$905.8	\$ 933.2	\$ 6.0	0.236	3.160	\$896.4	\$910.7	\$913.4	\$915.9
74	10.50%		\$883.0	\$903.8	\$ 929.2	\$ 5.9	0.248	3.159	\$894.5	\$908.6	\$911.5	\$913.9
74	1.88%		\$869.4	\$889.5	\$ 913.0	\$ 5.8	0.229	3.042	\$880.4	\$894.4	\$897.1	\$899.4
74	13.00%		\$858.3	\$878.3	\$ 900.5	\$ 5.8	0.249	3.093	\$869.3	\$882.9	\$885.9	\$888.3
74	5.25%		\$839.9	\$856.6	\$ 880.1	\$ 5.6	0.215	2.982	\$847.8	\$861.3	\$864.0	\$866.4
74	6.50%		\$824.3	\$845.0	\$ 871.1	\$ 5.6	0.237	3.153	\$836.2	\$849.6	\$852.2	\$854.5
74	8.50%		\$808.9	\$827.1	\$ 849.0	\$ 5.5	0.217	3.025	\$818.5	\$831.7	\$834.3	\$836.6
75	10.00%		\$890.3	\$910.0	\$ 933.1	\$ 5.9	0.235	3.018	\$900.8	\$914.9	\$917.7	\$920.1
75	0.30%		\$887.0	\$906.8	\$ 929.8	\$ 5.8	0.203	3.048	\$897.5	\$911.7	\$914.3	\$916.8
75	10.50%		\$887.5	\$904.7	\$ 927.6	\$ 5.8	0.209	2.981	\$895.4	\$909.6	\$912.4	\$914.7
75	1.88%		\$871.0	\$890.3	\$ 915.6	\$ 5.8	0.229	2.998	\$881.3	\$895.2	\$898.0	\$900.2
75	13.00%		\$860.5	\$879.0	\$ 905.3	\$ 5.7	0.219	3.032	\$869.9	\$883.7	\$886.4	\$888.7
75	5.25%		\$840.6	\$857.1	\$ 879.0	\$ 5.6	0.259	3.025	\$848.3	\$861.7	\$864.4	\$866.8
75	6.50%		\$828.1	\$845.4	\$ 867.6	\$ 5.5	0.230	3.055	\$836.6	\$850.0	\$852.6	\$854.8
75	8.50%		\$810.3	\$827.2	\$ 850.1	\$ 5.4	0.205	3.010	\$818.8	\$831.7	\$834.3	\$836.3

76	10.00%		\$890.9	\$911.0	\$ 934.2	\$ 5.9	0.248	3.116	\$901.9	\$915.8	\$918.7	\$920.9
76	0.30%		\$889.5	\$907.8	\$ 930.7	\$ 5.7	0.260	3.089	\$898.8	\$912.5	\$915.3	\$917.6
76	10.50%		\$887.0	\$905.7	\$ 933.6	\$ 5.9	0.236	3.110	\$896.4	\$910.5	\$913.3	\$915.9
76	1.88%		\$871.7	\$891.1	\$ 918.7	\$ 5.7	0.253	3.152	\$882.2	\$895.8	\$898.5	\$900.9
76	13.00%		\$863.3	\$879.7	\$ 905.4	\$ 5.7	0.254	3.091	\$870.8	\$884.4	\$887.0	\$889.3
76	5.25%		\$844.6	\$862.2	\$ 883.3	\$ 5.6	0.221	3.037	\$853.4	\$866.9	\$869.5	\$871.7
76	16.50%		\$828.8	\$845.7	\$ 869.6	\$ 5.5	0.247	3.076	\$837.0	\$850.2	\$853.0	\$855.2
76	8.50%		\$812.0	\$827.4	\$ 854.6	\$ 5.4	0.251	3.133	\$818.9	\$831.8	\$834.4	\$836.6

III. Simulation output result for BetaGeneral Experiment III(5.01, 50.10, 90%, 200%)

Duration	r	Graph	Min	Mean	Max	Std Dev	Skewness	Kurtosis	5%	80%	90%	95%
60	10.00%		\$937.3	\$973.0	\$ 1,034.0	\$ 12.1	0.437	3.244	\$954.8	\$994.3	\$983.0	\$989.0
60	0.30%		\$938.8	\$970.5	\$ 1,031.9	\$ 11.9	0.397	3.126	\$952.6	\$991.2	\$980.2	\$986.6
60	10.50%		\$935.8	\$968.8	\$ 1,022.4	\$ 11.9	0.419	3.203	\$950.9	\$989.7	\$978.6	\$984.6
60	1.88%		\$923.7	\$957.6	\$ 1,026.2	\$ 12.0	0.435	3.296	\$939.5	\$979.0	\$967.2	\$973.6
60	13.00%		\$917.7	\$948.7	\$ 1,006.6	\$ 11.8	0.424	3.240	\$930.9	\$969.5	\$958.3	\$964.5
60	5.25%		\$898.9	\$931.4	\$ 994.2	\$ 11.6	0.484	3.440	\$913.8	\$951.8	\$940.7	\$946.6
60	16.50%		\$886.8	\$922.1	\$ 982.3	\$ 11.6	0.437	3.388	\$904.5	\$942.6	\$931.4	\$937.5
60	8.50%		\$875.7	\$907.7	\$ 960.7	\$ 11.3	0.421	3.280	\$890.5	\$927.4	\$916.7	\$922.5
61	10.00%		\$924.2	\$956.0	\$ 1,007.2	\$ 11.7	0.467	3.344	\$938.5	\$976.6	\$965.6	\$971.3
61	0.30%		\$922.0	\$953.5	\$ 1,004.7	\$ 11.5	0.440	3.270	\$935.9	\$973.7	\$962.8	\$968.6
61	10.50%		\$920.6	\$951.9	\$ 1,009.5	\$ 11.5	0.431	3.242	\$934.4	\$972.3	\$961.1	\$967.0
61	1.88%		\$909.5	\$940.8	\$ 1,010.6	\$ 11.6	0.503	3.427	\$923.6	\$961.1	\$950.2	\$955.9
61	13.00%		\$903.2	\$936.7	\$ 1,002.0	\$ 11.2	0.414	3.311	\$919.6	\$956.3	\$945.8	\$951.7
61	5.25%		\$882.3	\$914.8	\$ 977.6	\$ 11.2	0.456	3.376	\$898.0	\$934.5	\$923.8	\$929.7
61	16.50%		\$871.6	\$905.6	\$ 955.3	\$ 11.2	0.425	3.230	\$888.7	\$925.3	\$914.8	\$920.5
61	8.50%		\$860.6	\$891.3	\$ 944.3	\$ 11.1	0.420	3.282	\$874.6	\$910.8	\$900.4	\$905.7

62	10.00%		\$913.8	\$944.5	\$ 1,004.1	\$ 11.1	0.431	3.330	\$927.4	\$964.0	\$953.4	\$959.3
62	0.30%		\$910.0	\$942.0	\$ 993.8	\$ 11.1	0.418	3.205	\$925.2	\$961.6	\$951.0	\$956.6
62	10.50%		\$908.6	\$940.3	\$ 998.9	\$ 11.2	0.435	3.259	\$923.3	\$960.0	\$949.4	\$954.9
62	1.88%		\$896.8	\$928.9	\$ 989.1	\$ 11.0	0.444	3.437	\$912.3	\$948.2	\$937.9	\$943.4
62	13.00%		\$890.3	\$919.9	\$ 976.3	\$ 11.0	0.398	3.285	\$903.1	\$938.9	\$929.0	\$934.3
62	5.25%		\$869.6	\$902.4	\$ 951.2	\$ 10.7	0.429	3.277	\$886.2	\$921.1	\$911.2	\$916.5
62	6.50%		\$860.4	\$893.1	\$ 941.3	\$ 10.7	0.440	3.307	\$877.3	\$911.7	\$901.7	\$907.3
62	8.50%		\$848.2	\$878.5	\$ 931.7	\$ 10.6	0.400	3.229	\$862.3	\$897.0	\$887.1	\$892.4
63	10.00%		\$902.4	\$933.0	\$ 980.7	\$ 10.6	0.383	3.156	\$916.9	\$951.3	\$941.8	\$947.0
63	0.30%		\$898.0	\$930.4	\$ 988.8	\$ 10.4	0.392	3.313	\$914.6	\$948.7	\$939.0	\$944.4
63	10.50%		\$897.7	\$928.7	\$ 977.0	\$ 10.4	0.388	3.248	\$912.7	\$946.8	\$937.3	\$942.4
63	1.88%		\$885.2	\$917.1	\$ 972.4	\$ 10.4	0.414	3.290	\$901.2	\$935.3	\$925.4	\$930.9
63	13.00%		\$877.7	\$907.9	\$ 962.4	\$ 10.3	0.404	3.288	\$892.0	\$925.9	\$916.3	\$921.5
63	5.25%		\$860.8	\$890.1	\$ 938.5	\$ 10.2	0.370	3.170	\$874.6	\$907.7	\$898.5	\$903.5
63	6.50%		\$849.8	\$878.6	\$ 928.5	\$ 9.7	0.400	3.260	\$863.9	\$895.7	\$886.7	\$891.3
63	8.50%		\$836.8	\$865.7	\$ 909.8	\$ 9.9	0.383	3.206	\$850.4	\$883.4	\$873.6	\$878.6
64	10.00%		\$888.1	\$917.0	\$ 958.9	\$ 9.8	0.344	3.159	\$901.7	\$934.0	\$925.0	\$930.0
64	0.30%		\$883.7	\$914.3	\$ 957.9	\$ 9.7	0.362	3.188	\$899.2	\$931.2	\$922.2	\$927.1
64	10.50%		\$884.6	\$912.5	\$ 957.6	\$ 9.7	0.394	3.239	\$897.7	\$929.8	\$920.4	\$925.4
64	1.88%		\$873.0	\$900.4	\$ 946.7	\$ 9.6	0.369	3.189	\$885.4	\$917.3	\$908.2	\$913.0
64	13.00%		\$859.4	\$890.8	\$ 938.9	\$ 9.5	0.368	3.242	\$876.1	\$907.4	\$898.5	\$903.2
64	5.25%		\$845.1	\$872.2	\$ 910.0	\$ 9.3	0.364	3.148	\$858.0	\$888.5	\$879.9	\$884.4
64	6.50%		\$835.8	\$862.2	\$ 902.6	\$ 9.2	0.346	3.115	\$848.1	\$878.3	\$869.8	\$874.3
64	8.50%		\$825.9	\$852.9	\$ 899.0	\$ 9.5	0.390	3.169	\$838.4	\$869.5	\$860.6	\$865.3
65	10.00%		\$870.6	\$900.0	\$ 942.1	\$ 9.4	0.311	3.035	\$885.5	\$916.3	\$907.8	\$912.3
65	0.30%		\$871.1	\$897.3	\$ 939.6	\$ 9.2	0.392	3.272	\$883.3	\$913.5	\$904.8	\$909.4

65	0.50%		\$865.3	\$895.6	\$ 937.3	\$ 9.2	0.372	3.201	\$881.5	\$911.9	\$903.2	\$907.7
65	1.88%		\$855.0	\$883.6	\$ 924.9	\$ 9.2	0.388	3.155	\$869.6	\$899.8	\$891.2	\$895.8
65	3.00%		\$845.8	\$874.1	\$ 917.4	\$ 9.1	0.338	3.104	\$860.0	\$889.9	\$881.5	\$886.0
65	5.25%		\$824.2	\$855.7	\$ 898.1	\$ 8.9	0.350	3.153	\$842.1	\$871.3	\$863.1	\$867.3
65	6.50%		\$816.9	\$845.8	\$ 899.6	\$ 8.8	0.398	3.263	\$832.4	\$861.2	\$852.9	\$857.5
65	8.50%		\$803.8	\$830.5	\$ 871.7	\$ 8.8	0.379	3.203	\$817.1	\$845.6	\$837.6	\$842.0
66	0.00%		\$873.5	\$901.0	\$ 942.3	\$ 9.2	0.316	3.104	\$887.0	\$916.8	\$908.5	\$912.8
66	0.30%		\$873.4	\$898.3	\$ 938.9	\$ 9.1	0.351	3.047	\$884.3	\$914.5	\$905.8	\$910.3
66	1.050%		\$869.3	\$896.5	\$ 938.4	\$ 9.1	0.344	3.178	\$882.4	\$912.2	\$904.0	\$908.4
66	1.88%		\$855.5	\$884.2	\$ 926.7	\$ 9.1	0.386	3.222	\$870.3	\$900.2	\$891.6	\$896.1
66	3.00%		\$849.3	\$874.5	\$ 914.6	\$ 9.0	0.364	3.145	\$860.6	\$890.4	\$881.7	\$886.4
66	5.25%		\$829.8	\$855.6	\$ 894.9	\$ 8.8	0.363	3.214	\$842.0	\$870.8	\$862.8	\$867.1
66	6.50%		\$818.4	\$845.5	\$ 881.3	\$ 8.7	0.319	3.041	\$832.1	\$860.6	\$852.7	\$857.0
66	8.50%		\$804.3	\$829.8	\$ 880.9	\$ 8.6	0.364	3.301	\$816.6	\$844.6	\$836.9	\$841.1
67	0.00%		\$872.4	\$902.0	\$ 949.9	\$ 9.1	0.387	3.358	\$888.1	\$917.6	\$909.3	\$913.8
67	0.30%		\$870.7	\$899.2	\$ 939.4	\$ 9.0	0.345	3.190	\$885.3	\$914.7	\$906.6	\$910.8
67	1.050%		\$869.3	\$897.4	\$ 954.6	\$ 9.1	0.373	3.349	\$883.5	\$913.2	\$904.8	\$909.2
67	1.88%		\$857.5	\$884.8	\$ 922.8	\$ 8.9	0.300	3.016	\$870.9	\$900.2	\$892.1	\$896.5
67	3.00%		\$847.5	\$874.8	\$ 921.1	\$ 8.8	0.347	3.152	\$861.3	\$890.3	\$882.1	\$886.4
67	5.25%		\$830.3	\$855.5	\$ 894.3	\$ 8.7	0.354	3.166	\$842.2	\$870.5	\$862.7	\$867.0
67	6.50%		\$819.5	\$845.2	\$ 887.5	\$ 8.6	0.367	3.204	\$832.0	\$860.3	\$852.2	\$856.4
67	8.50%		\$804.6	\$829.2	\$ 865.5	\$ 8.5	0.356	3.138	\$816.2	\$844.1	\$836.1	\$840.4
68	0.00%		\$876.4	\$903.0	\$ 949.1	\$ 8.9	0.393	3.296	\$889.2	\$918.5	\$910.2	\$914.6
68	0.30%		\$873.3	\$900.1	\$ 938.7	\$ 8.9	0.335	3.181	\$886.4	\$915.4	\$907.4	\$911.7
68	1.050%		\$870.9	\$898.3	\$ 936.5	\$ 8.9	0.374	3.217	\$884.6	\$913.9	\$905.4	\$909.9
68	1.88%		\$859.1	\$885.4	\$ 924.0	\$ 8.7	0.336	3.131	\$872.1	\$900.3	\$892.5	\$896.8

68	3.00%		\$846.7	\$875.2	\$ 920.0	\$ 8.8	0.379	3.208	\$861.8	\$890.7	\$882.4	\$886.8
68	5.25%		\$828.6	\$855.5	\$ 896.1	\$ 8.6	0.347	3.185	\$842.3	\$870.5	\$862.3	\$866.7
68	6.50%		\$817.5	\$844.9	\$ 883.4	\$ 8.5	0.332	3.231	\$831.6	\$859.7	\$851.9	\$855.9
68	8.50%		\$803.4	\$828.5	\$ 867.9	\$ 8.4	0.358	3.197	\$815.6	\$843.1	\$835.4	\$839.5
69	10.00%		\$878.0	\$904.0	\$ 947.2	\$ 8.8	0.343	3.178	\$890.3	\$919.2	\$911.3	\$915.5
69	0.30%		\$875.7	\$901.1	\$ 938.7	\$ 8.9	0.305	3.087	\$887.2	\$916.5	\$908.4	\$912.8
69	0.50%		\$871.5	\$899.2	\$ 938.8	\$ 8.7	0.318	3.180	\$885.7	\$914.1	\$906.5	\$910.6
69	1.88%		\$860.2	\$886.0	\$ 927.5	\$ 8.7	0.359	3.202	\$872.5	\$901.3	\$893.2	\$897.5
69	3.00%		\$848.5	\$875.6	\$ 916.9	\$ 8.6	0.329	3.134	\$862.2	\$890.4	\$882.8	\$886.9
69	5.25%		\$830.2	\$855.4	\$ 893.2	\$ 8.4	0.325	3.066	\$842.4	\$870.0	\$862.4	\$866.5
69	6.50%		\$819.9	\$844.6	\$ 881.4	\$ 8.3	0.333	3.085	\$831.8	\$859.2	\$851.5	\$855.6
69	8.50%		\$802.4	\$827.9	\$ 866.9	\$ 8.2	0.352	3.127	\$815.4	\$842.3	\$834.6	\$838.9
70	10.00%		\$876.0	\$905.0	\$ 944.0	\$ 8.7	0.341	3.205	\$891.5	\$919.8	\$912.2	\$916.3
70	0.30%		\$873.9	\$902.0	\$ 942.8	\$ 8.7	0.319	3.071	\$888.7	\$917.1	\$909.3	\$913.6
70	0.50%		\$871.3	\$900.1	\$ 944.1	\$ 8.7	0.373	3.286	\$886.5	\$915.2	\$907.2	\$911.5
70	1.88%		\$860.0	\$886.6	\$ 926.1	\$ 8.6	0.338	3.160	\$873.3	\$901.5	\$893.7	\$898.0
70	3.00%		\$847.8	\$875.9	\$ 917.8	\$ 8.5	0.342	3.227	\$862.9	\$890.4	\$883.0	\$886.9
70	5.25%		\$831.1	\$855.4	\$ 894.7	\$ 8.3	0.362	3.180	\$842.6	\$870.0	\$862.1	\$866.2
70	6.50%		\$816.9	\$844.3	\$ 882.8	\$ 8.3	0.325	3.133	\$831.5	\$858.6	\$851.2	\$855.3
70	8.50%		\$803.3	\$827.3	\$ 863.0	\$ 8.1	0.312	3.102	\$814.7	\$841.1	\$833.9	\$838.0
71	10.00%		\$879.3	\$906.0	\$ 944.1	\$ 8.6	0.334	3.124	\$892.9	\$921.0	\$913.2	\$917.3
71	0.30%		\$874.4	\$902.9	\$ 946.2	\$ 8.6	0.321	3.109	\$889.6	\$918.1	\$910.2	\$914.3
71	0.50%		\$876.0	\$901.0	\$ 937.2	\$ 8.6	0.321	3.080	\$887.7	\$915.8	\$908.0	\$912.2
71	1.88%		\$861.5	\$887.2	\$ 926.5	\$ 8.4	0.377	3.219	\$874.2	\$901.9	\$894.1	\$898.0
71	3.00%		\$852.5	\$876.3	\$ 910.6	\$ 8.4	0.319	3.101	\$863.3	\$890.9	\$883.2	\$887.4

71	15.25%		\$830.4	\$855.3	\$ 892.4	\$ 8.3	0.346	3.101	\$842.4	\$870.0	\$862.1	\$866.5
71	6.50%		\$819.7	\$844.0	\$ 880.8	\$ 8.1	0.302	3.089	\$831.5	\$858.1	\$850.7	\$854.7
71	18.50%		\$802.6	\$826.6	\$ 865.5	\$ 8.0	0.323	3.221	\$814.2	\$840.3	\$833.1	\$837.0
72	0.00%		\$882.1	\$907.0	\$ 944.8	\$ 8.5	0.345	3.218	\$893.9	\$921.8	\$913.9	\$918.1
72	10.30%		\$877.4	\$903.9	\$ 943.2	\$ 8.5	0.311	3.127	\$890.8	\$918.8	\$910.9	\$915.0
72	0.50%		\$876.5	\$901.9	\$ 939.0	\$ 8.6	0.326	3.032	\$888.7	\$916.8	\$909.1	\$913.4
72	11.88%		\$862.1	\$888.0	\$ 924.0	\$ 8.4	0.300	3.078	\$874.9	\$902.2	\$895.0	\$898.9
72	3.00%		\$852.6	\$877.0	\$ 913.1	\$ 8.4	0.344	3.113	\$864.2	\$891.6	\$883.8	\$887.9
72	15.25%		\$831.0	\$855.7	\$ 892.7	\$ 8.1	0.322	3.222	\$843.3	\$869.7	\$862.4	\$866.1
72	6.50%		\$820.7	\$844.4	\$ 879.8	\$ 8.1	0.352	3.161	\$831.9	\$858.6	\$851.0	\$855.1
72	18.50%		\$804.7	\$826.8	\$ 860.1	\$ 7.9	0.335	3.065	\$814.5	\$840.7	\$833.4	\$837.2
73	0.00%		\$882.3	\$908.0	\$ 954.1	\$ 8.4	0.376	3.193	\$895.1	\$922.9	\$914.9	\$919.2
73	10.30%		\$876.6	\$904.9	\$ 952.1	\$ 8.5	0.367	3.166	\$891.7	\$919.8	\$911.9	\$916.1
73	0.50%		\$877.5	\$902.9	\$ 944.8	\$ 8.4	0.328	3.105	\$890.1	\$917.4	\$909.9	\$913.9
73	11.88%		\$860.9	\$888.8	\$ 934.0	\$ 8.4	0.341	3.187	\$875.8	\$903.4	\$895.8	\$899.9
73	3.00%		\$853.2	\$877.7	\$ 918.6	\$ 8.3	0.344	3.142	\$864.9	\$892.0	\$884.6	\$888.6
73	15.25%		\$828.3	\$856.2	\$ 894.7	\$ 8.1	0.306	3.059	\$843.8	\$870.4	\$862.9	\$866.9
73	6.50%		\$823.5	\$844.7	\$ 883.1	\$ 8.0	0.367	3.168	\$832.5	\$858.6	\$851.2	\$855.2
73	18.50%		\$803.2	\$826.9	\$ 864.3	\$ 8.0	0.352	3.113	\$814.6	\$840.9	\$833.5	\$837.6
74	0.00%		\$885.1	\$909.0	\$ 942.9	\$ 8.5	0.345	3.059	\$896.0	\$923.9	\$916.0	\$920.2
74	10.30%		\$879.6	\$905.8	\$ 942.7	\$ 8.4	0.327	3.105	\$892.9	\$920.5	\$912.8	\$916.9
74	0.50%		\$879.5	\$903.8	\$ 946.3	\$ 8.3	0.363	3.268	\$890.9	\$918.3	\$910.6	\$914.6
74	11.88%		\$865.0	\$889.5	\$ 928.3	\$ 8.2	0.360	3.181	\$876.9	\$904.0	\$896.2	\$900.3
74	3.00%		\$851.4	\$878.3	\$ 920.6	\$ 8.1	0.361	3.218	\$865.8	\$892.4	\$885.1	\$888.9
74	15.25%		\$830.2	\$856.6	\$ 892.0	\$ 8.0	0.336	3.057	\$844.4	\$870.7	\$863.3	\$867.3
74	6.50%		\$821.7	\$845.0	\$ 884.3	\$ 8.0	0.325	3.082	\$832.7	\$858.8	\$851.5	\$855.6
74	18.50%		\$803.3	\$827.1	\$ 864.0	\$ 7.7	0.363	3.212	\$815.2	\$840.5	\$833.4	\$837.2

75	10.00%		\$885.0	\$910.0	\$ 945.9	\$ 8.4	0.394	3.216	\$897.3	\$924.7	\$916.8	\$921.0
75	0.30%		\$883.3	\$906.8	\$ 943.9	\$ 8.4	0.320	3.114	\$893.8	\$921.1	\$913.6	\$917.8
75	10.50%		\$879.3	\$904.7	\$ 940.8	\$ 8.3	0.355	3.224	\$892.0	\$919.4	\$911.5	\$915.6
75	1.88%		\$863.0	\$890.3	\$ 925.7	\$ 8.3	0.355	3.163	\$877.4	\$904.7	\$897.1	\$901.0
75	13.00%		\$852.2	\$879.0	\$ 913.9	\$ 8.1	0.381	3.162	\$866.5	\$893.3	\$885.6	\$889.9
75	5.25%		\$832.3	\$857.1	\$ 889.9	\$ 8.0	0.345	3.172	\$844.8	\$871.1	\$863.6	\$867.6
75	16.50%		\$820.2	\$845.4	\$ 886.8	\$ 7.9	0.332	3.278	\$833.3	\$859.1	\$851.7	\$855.5
75	8.50%		\$805.0	\$827.2	\$ 866.8	\$ 7.7	0.375	3.284	\$815.5	\$840.5	\$833.5	\$837.2
76	10.00%		\$884.8	\$911.0	\$ 946.5	\$ 8.4	0.323	3.079	\$898.0	\$925.3	\$917.9	\$922.0
76	0.30%		\$882.6	\$907.8	\$ 944.0	\$ 8.3	0.339	3.177	\$894.8	\$922.1	\$914.6	\$918.6
76	10.50%		\$879.9	\$905.7	\$ 948.6	\$ 8.3	0.356	3.204	\$893.0	\$920.1	\$912.5	\$916.4
76	1.88%		\$867.0	\$891.1	\$ 930.5	\$ 8.2	0.368	3.164	\$878.6	\$905.5	\$897.9	\$902.0
76	13.00%		\$856.4	\$879.7	\$ 913.6	\$ 8.0	0.364	3.089	\$867.4	\$893.9	\$886.3	\$890.3
76	5.25%		\$839.4	\$862.2	\$ 898.9	\$ 8.0	0.359	3.196	\$849.8	\$876.0	\$868.8	\$872.7
76	16.50%		\$820.9	\$845.7	\$ 877.3	\$ 7.9	0.354	3.148	\$833.7	\$859.6	\$852.1	\$856.0
76	8.50%		\$804.8	\$827.4	\$ 863.5	\$ 7.6	0.353	3.206	\$815.7	\$840.6	\$833.5	\$837.2

IV. Simulation output result for BetaGeneral Experiment IV(8.33, 62.49, 80%, 250%)

Duration	r	Graph	Min	Mean	Max	Std Dev	Skewness	Kurtosis	5%	80%	90%	95%
60	10.00%		\$915.6	\$973.0	\$ 1,044.8	\$ 18.5	0.298	3.070	\$944.4	\$978.2	\$980.9	\$ 1,005.2
60	0.30%		\$912.1	\$970.5	\$ 1,054.2	\$ 18.2	0.309	3.057	\$942.0	\$975.6	\$978.3	\$ 1,002.2
60	10.50%		\$913.7	\$968.8	\$ 1,046.0	\$ 18.6	0.293	3.057	\$939.9	\$974.0	\$976.7	\$ 1,000.8
60	1.88%		\$901.7	\$957.6	\$ 1,056.6	\$ 18.2	0.355	3.192	\$929.7	\$962.7	\$965.3	\$ 989.3
60	13.00%		\$892.3	\$948.7	\$ 1,028.9	\$ 18.1	0.352	3.211	\$920.9	\$953.7	\$956.5	\$ 979.9
60	5.25%		\$878.1	\$931.4	\$ 1,013.8	\$ 18.0	0.344	3.149	\$903.7	\$936.3	\$939.0	\$ 962.5
60	16.50%		\$868.8	\$922.1	\$ 1,018.3	\$ 17.7	0.340	3.340	\$894.5	\$927.0	\$929.7	\$ 952.5
60	8.50%		\$854.5	\$907.7	\$ 988.3	\$ 17.5	0.283	3.070	\$880.8	\$912.5	\$915.1	\$ 937.9

61	10.00%		\$902.3	\$956.0	\$ 1,035.1	\$ 17.9	0.339	3.187	\$928.4	\$960.9	\$963.7	\$ 987.4
61	0.30%		\$901.4	\$953.5	\$ 1,029.9	\$ 17.7	0.335	3.184	\$926.3	\$958.4	\$961.1	\$ 984.2
61	10.50%		\$896.7	\$951.9	\$ 1,029.2	\$ 17.7	0.306	3.168	\$924.2	\$956.9	\$959.4	\$ 982.6
61	1.88%		\$889.2	\$940.8	\$ 1,025.5	\$ 17.7	0.325	3.108	\$913.6	\$945.7	\$948.2	\$ 971.4
61	13.00%		\$886.5	\$936.7	\$ 1,009.3	\$ 17.2	0.284	3.121	\$909.8	\$941.5	\$943.9	\$ 966.0
61	5.25%		\$865.6	\$914.8	\$ 993.0	\$ 17.2	0.290	3.119	\$888.0	\$919.6	\$922.3	\$ 944.6
61	16.50%		\$853.5	\$905.6	\$ 983.4	\$ 17.1	0.286	3.102	\$879.3	\$910.4	\$912.8	\$ 935.1
61	8.50%		\$839.8	\$891.3	\$ 964.7	\$ 16.9	0.293	3.018	\$865.2	\$896.1	\$898.6	\$ 920.5
62	10.00%		\$893.5	\$944.5	\$ 1,024.7	\$ 16.9	0.337	3.260	\$918.5	\$949.3	\$951.8	\$ 973.6
62	0.30%		\$885.3	\$942.0	\$ 1,018.1	\$ 17.0	0.301	3.105	\$915.5	\$946.6	\$949.1	\$ 971.3
62	10.50%		\$887.6	\$940.3	\$ 1,012.9	\$ 16.9	0.326	3.201	\$914.3	\$945.0	\$947.5	\$ 969.8
62	1.88%		\$876.7	\$928.9	\$ 1,007.0	\$ 16.8	0.313	3.211	\$902.6	\$933.6	\$936.1	\$ 958.6
62	13.00%		\$860.1	\$919.9	\$ 1,001.9	\$ 16.7	0.279	3.085	\$893.8	\$924.6	\$926.9	\$ 949.2
62	5.25%		\$845.8	\$902.4	\$ 972.7	\$ 16.4	0.314	3.199	\$877.2	\$907.0	\$909.5	\$ 931.0
62	16.50%		\$842.7	\$893.1	\$ 970.1	\$ 16.3	0.297	3.085	\$867.9	\$897.5	\$899.8	\$ 921.2
62	8.50%		\$824.5	\$878.5	\$ 954.7	\$ 16.1	0.328	3.246	\$853.7	\$882.9	\$885.4	\$ 906.2
63	10.00%		\$881.6	\$933.0	\$ 1,002.6	\$ 16.1	0.302	3.147	\$907.8	\$937.6	\$939.9	\$ 960.7
63	0.30%		\$883.9	\$930.4	\$ 1,005.5	\$ 16.1	0.317	3.201	\$905.5	\$935.0	\$937.2	\$ 958.3
63	10.50%		\$879.7	\$928.7	\$ 999.1	\$ 16.2	0.332	3.266	\$903.5	\$933.1	\$935.5	\$ 956.7
63	1.88%		\$871.2	\$917.1	\$ 984.2	\$ 16.0	0.290	3.051	\$892.2	\$921.6	\$923.9	\$ 944.8
63	13.00%		\$857.7	\$907.9	\$ 985.4	\$ 15.7	0.290	3.179	\$883.2	\$912.3	\$914.7	\$ 935.1
63	5.25%		\$845.1	\$890.1	\$ 974.7	\$ 15.7	0.296	3.193	\$865.3	\$894.4	\$896.6	\$ 917.0
63	16.50%		\$831.2	\$878.6	\$ 940.7	\$ 14.9	0.247	3.073	\$855.2	\$882.7	\$884.9	\$ 904.3
63	8.50%		\$817.8	\$865.7	\$ 923.1	\$ 15.2	0.287	2.996	\$841.9	\$869.9	\$872.2	\$ 892.0
64	10.00%		\$864.1	\$917.0	\$ 981.8	\$ 15.1	0.217	3.066	\$893.1	\$921.2	\$923.4	\$ 942.6
64	0.30%		\$864.3	\$914.3	\$ 982.8	\$ 14.9	0.257	3.182	\$891.3	\$918.5	\$920.7	\$ 939.4

64	10.50%		\$863.1	\$912.5	\$ 973.4	\$ 15.0	0.317	3.139	\$889.6	\$916.6	\$918.8	\$ 938.5
64	1.88%		\$856.4	\$900.4	\$ 966.2	\$ 14.8	0.255	3.091	\$877.1	\$904.5	\$906.6	\$ 925.9
64	13.00%		\$842.0	\$890.8	\$ 952.8	\$ 14.6	0.281	3.119	\$868.0	\$894.9	\$897.0	\$ 915.7
64	5.25%		\$829.8	\$872.2	\$ 933.1	\$ 14.4	0.274	3.046	\$850.1	\$876.2	\$878.3	\$ 897.0
64	16.50%		\$813.4	\$862.2	\$ 918.2	\$ 14.4	0.236	3.049	\$839.5	\$866.1	\$868.2	\$ 887.0
64	8.50%		\$803.7	\$852.9	\$ 920.1	\$ 14.6	0.269	3.137	\$830.2	\$856.9	\$859.1	\$ 877.6
65	10.00%		\$852.5	\$900.0	\$ 975.2	\$ 14.2	0.245	3.147	\$877.4	\$904.0	\$906.0	\$ 924.0
65	0.30%		\$852.1	\$897.3	\$ 965.7	\$ 14.1	0.247	3.136	\$874.9	\$901.2	\$903.3	\$ 921.8
65	10.50%		\$849.2	\$895.6	\$ 957.3	\$ 14.1	0.267	3.045	\$873.5	\$899.4	\$901.5	\$ 919.8
65	1.88%		\$834.6	\$883.6	\$ 936.7	\$ 14.0	0.257	3.051	\$861.7	\$887.5	\$889.5	\$ 907.9
65	13.00%		\$827.7	\$874.1	\$ 932.2	\$ 14.0	0.255	3.057	\$852.2	\$878.0	\$879.9	\$ 897.9
65	5.25%		\$806.0	\$855.7	\$ 917.2	\$ 13.7	0.278	3.131	\$834.5	\$859.4	\$861.4	\$ 878.9
65	16.50%		\$800.6	\$845.8	\$ 902.5	\$ 13.5	0.240	3.109	\$824.2	\$849.5	\$851.5	\$ 868.6
65	8.50%		\$786.4	\$830.5	\$ 904.6	\$ 13.3	0.266	3.233	\$809.7	\$834.2	\$836.1	\$ 852.9
66	10.00%		\$854.8	\$901.0	\$ 960.3	\$ 14.0	0.240	3.056	\$879.2	\$904.9	\$907.1	\$ 924.6
66	0.30%		\$856.1	\$898.3	\$ 963.6	\$ 14.0	0.283	3.201	\$876.4	\$902.3	\$904.2	\$ 922.4
66	10.50%		\$852.5	\$896.5	\$ 968.6	\$ 14.0	0.262	3.166	\$874.5	\$900.3	\$902.5	\$ 920.6
66	1.88%		\$841.4	\$884.2	\$ 941.4	\$ 13.8	0.270	3.095	\$862.5	\$888.1	\$890.0	\$ 908.1
66	13.00%		\$830.0	\$874.5	\$ 936.7	\$ 13.7	0.261	3.078	\$853.0	\$878.2	\$880.2	\$ 897.7
66	5.25%		\$812.3	\$855.6	\$ 912.8	\$ 13.4	0.237	3.061	\$834.4	\$859.3	\$861.3	\$ 878.2
66	16.50%		\$798.0	\$845.5	\$ 903.6	\$ 13.4	0.252	3.114	\$824.3	\$849.2	\$851.1	\$ 868.3
66	8.50%		\$788.3	\$829.8	\$ 883.2	\$ 13.1	0.275	3.046	\$809.6	\$833.5	\$835.4	\$ 852.6
67	10.00%		\$858.7	\$902.0	\$ 965.0	\$ 13.9	0.261	3.088	\$880.4	\$905.8	\$908.0	\$ 925.9
67	0.30%		\$853.7	\$899.2	\$ 964.5	\$ 13.9	0.258	3.141	\$877.4	\$903.1	\$905.2	\$ 922.8
67	10.50%		\$850.6	\$897.4	\$ 954.5	\$ 13.7	0.288	3.150	\$876.1	\$901.2	\$903.3	\$ 921.4
67	1.88%		\$844.3	\$884.8	\$ 943.9	\$ 13.7	0.308	3.102	\$863.5	\$888.6	\$890.6	\$ 908.4

67	13.00%		\$830.3	\$874.8	\$ 932.8	\$ 13.6	0.259	3.100	\$853.5	\$878.5	\$880.5	\$ 898.1
67	5.25%		\$815.3	\$855.5	\$ 912.8	\$ 13.2	0.237	3.083	\$834.4	\$859.3	\$861.2	\$ 878.2
67	16.50%		\$804.5	\$845.2	\$ 910.3	\$ 13.1	0.255	3.069	\$824.8	\$848.8	\$850.7	\$ 867.8
67	8.50%		\$788.5	\$829.2	\$ 883.8	\$ 13.1	0.266	3.086	\$808.5	\$832.8	\$834.6	\$ 851.9
68	10.00%		\$859.6	\$903.0	\$ 958.0	\$ 13.7	0.290	3.019	\$881.6	\$906.9	\$908.8	\$ 926.7
68	0.30%		\$858.0	\$900.1	\$ 955.0	\$ 13.8	0.265	2.995	\$878.5	\$904.0	\$906.0	\$ 923.8
68	10.50%		\$855.5	\$898.3	\$ 965.4	\$ 13.4	0.236	3.089	\$877.2	\$902.0	\$904.0	\$ 921.5
68	1.88%		\$838.5	\$885.4	\$ 940.4	\$ 13.4	0.288	3.165	\$864.6	\$889.1	\$891.2	\$ 908.7
68	13.00%		\$834.3	\$875.2	\$ 932.8	\$ 13.3	0.278	3.065	\$854.4	\$878.9	\$880.9	\$ 898.1
68	5.25%		\$811.5	\$855.5	\$ 917.5	\$ 13.1	0.299	3.201	\$835.0	\$859.1	\$861.1	\$ 878.0
68	16.50%		\$803.7	\$844.9	\$ 894.2	\$ 12.9	0.211	2.904	\$824.6	\$848.5	\$850.3	\$ 866.8
68	8.50%		\$789.7	\$828.5	\$ 885.1	\$ 12.7	0.244	3.089	\$808.6	\$832.1	\$834.0	\$ 850.4
69	10.00%		\$861.3	\$904.0	\$ 965.0	\$ 13.6	0.272	3.066	\$882.7	\$907.8	\$909.8	\$ 927.0
69	0.30%		\$855.7	\$901.1	\$ 960.8	\$ 13.6	0.290	3.233	\$879.8	\$904.8	\$906.7	\$ 924.7
69	10.50%		\$856.7	\$899.2	\$ 960.0	\$ 13.5	0.242	2.987	\$877.9	\$902.9	\$904.8	\$ 922.5
69	1.88%		\$843.7	\$886.0	\$ 937.7	\$ 13.4	0.244	2.992	\$865.2	\$889.7	\$891.5	\$ 908.8
69	13.00%		\$835.6	\$875.6	\$ 930.1	\$ 13.2	0.262	3.039	\$854.7	\$879.3	\$881.1	\$ 898.3
69	5.25%		\$815.5	\$855.4	\$ 914.5	\$ 12.9	0.302	3.264	\$835.2	\$859.0	\$860.9	\$ 876.9
69	16.50%		\$798.5	\$844.6	\$ 895.0	\$ 12.8	0.266	3.098	\$824.6	\$848.3	\$850.1	\$ 866.6
69	8.50%		\$783.7	\$827.9	\$ 892.3	\$ 12.6	0.245	3.096	\$808.1	\$831.4	\$833.3	\$ 849.3
70	10.00%		\$854.0	\$905.0	\$ 964.0	\$ 13.4	0.233	3.089	\$884.1	\$908.6	\$910.6	\$ 927.7
70	0.30%		\$860.7	\$902.0	\$ 951.7	\$ 13.5	0.257	3.010	\$881.1	\$905.7	\$907.6	\$ 925.1
70	10.50%		\$853.3	\$900.1	\$ 979.6	\$ 13.2	0.246	3.180	\$879.3	\$903.7	\$905.6	\$ 922.8
70	1.88%		\$844.4	\$886.6	\$ 936.6	\$ 13.0	0.238	2.982	\$866.2	\$890.2	\$892.2	\$ 909.2
70	13.00%		\$836.6	\$875.9	\$ 927.2	\$ 13.0	0.227	2.960	\$855.5	\$879.5	\$881.5	\$ 898.0
70	5.25%		\$813.9	\$855.4	\$ 915.5	\$ 12.7	0.242	3.085	\$835.4	\$858.9	\$860.6	\$ 877.0

70	6.50%		\$803.2	\$844.3	\$ 893.0	\$ 12.4	0.247	3.035	\$824.7	\$847.8	\$849.6	\$ 865.6
70	8.50%		\$783.6	\$827.3	\$ 879.3	\$ 12.4	0.265	3.051	\$807.9	\$830.7	\$832.5	\$ 848.6
71	10.00%		\$859.4	\$906.0	\$ 958.3	\$ 13.1	0.263	3.005	\$885.8	\$909.7	\$911.7	\$ 928.8
71	0.30%		\$865.3	\$902.9	\$ 970.5	\$ 13.1	0.234	3.104	\$882.0	\$906.6	\$908.5	\$ 925.5
71	10.50%		\$855.6	\$901.0	\$ 961.9	\$ 13.2	0.236	3.116	\$880.2	\$904.6	\$906.4	\$ 923.1
71	1.88%		\$845.3	\$887.2	\$ 939.3	\$ 13.0	0.251	3.068	\$866.8	\$890.7	\$892.5	\$ 909.3
71	13.00%		\$836.9	\$876.3	\$ 933.7	\$ 12.8	0.228	2.998	\$856.3	\$879.9	\$881.8	\$ 898.1
71	5.25%		\$814.8	\$855.3	\$ 912.9	\$ 12.6	0.225	3.063	\$835.3	\$858.8	\$860.6	\$ 876.6
71	6.50%		\$803.4	\$844.0	\$ 888.8	\$ 12.4	0.222	3.024	\$824.3	\$847.5	\$849.3	\$ 865.7
71	8.50%		\$783.7	\$826.6	\$ 889.0	\$ 12.2	0.269	3.170	\$807.7	\$830.0	\$831.8	\$ 847.4
72	10.00%		\$865.5	\$907.0	\$ 975.2	\$ 13.3	0.278	3.130	\$886.2	\$910.6	\$912.5	\$ 929.7
72	0.30%		\$856.4	\$903.9	\$ 961.7	\$ 13.0	0.240	3.146	\$883.4	\$907.5	\$909.4	\$ 926.0
72	10.50%		\$858.0	\$901.9	\$ 957.1	\$ 13.0	0.269	3.021	\$881.6	\$905.5	\$907.5	\$ 924.2
72	1.88%		\$846.8	\$888.0	\$ 951.3	\$ 12.9	0.242	3.075	\$867.9	\$891.5	\$893.4	\$ 910.0
72	13.00%		\$832.2	\$877.0	\$ 937.6	\$ 12.7	0.202	3.029	\$856.7	\$880.5	\$882.4	\$ 898.7
72	5.25%		\$815.7	\$855.7	\$ 916.5	\$ 12.4	0.279	3.107	\$836.2	\$859.2	\$861.0	\$ 877.3
72	6.50%		\$802.3	\$844.4	\$ 901.5	\$ 12.3	0.273	3.122	\$824.9	\$847.8	\$849.5	\$ 865.6
72	8.50%		\$785.9	\$826.8	\$ 878.0	\$ 12.1	0.256	3.091	\$808.1	\$830.1	\$831.9	\$ 847.5
73	10.00%		\$865.3	\$908.0	\$ 963.4	\$ 12.9	0.218	3.160	\$887.3	\$911.6	\$913.4	\$ 929.5
73	0.30%		\$865.8	\$904.9	\$ 959.9	\$ 12.8	0.235	3.069	\$884.6	\$908.5	\$910.4	\$ 926.8
73	10.50%		\$861.8	\$902.9	\$ 954.2	\$ 12.7	0.188	2.942	\$882.8	\$906.5	\$908.3	\$ 924.5
73	1.88%		\$847.7	\$888.8	\$ 946.0	\$ 12.7	0.242	3.005	\$868.8	\$892.3	\$894.1	\$ 910.5
73	13.00%		\$833.5	\$877.7	\$ 940.5	\$ 12.6	0.247	3.112	\$857.7	\$881.1	\$883.0	\$ 899.5
73	5.25%		\$820.7	\$856.2	\$ 905.2	\$ 12.4	0.234	2.997	\$836.5	\$859.6	\$861.4	\$ 877.5
73	6.50%		\$808.3	\$844.7	\$ 890.7	\$ 12.1	0.272	2.991	\$825.9	\$848.0	\$849.9	\$ 865.7
73	8.50%		\$788.0	\$826.9	\$ 887.9	\$ 12.1	0.272	3.150	\$808.0	\$830.2	\$832.1	\$ 847.6

74	10.00%		\$866.0	\$909.0	\$ 959.3	\$ 12.8	0.248	2.987	\$888.8	\$912.6	\$914.4	\$ 931.0
74	0.30%		\$866.6	\$905.8	\$ 966.1	\$ 12.8	0.270	3.075	\$885.9	\$909.4	\$911.3	\$ 927.5
74	10.50%		\$860.4	\$903.8	\$ 964.4	\$ 12.9	0.243	3.072	\$883.6	\$907.4	\$909.3	\$ 926.0
74	1.88%		\$847.2	\$889.5	\$ 944.3	\$ 12.7	0.212	3.058	\$869.5	\$893.0	\$894.8	\$ 911.4
74	13.00%		\$833.2	\$878.3	\$ 929.5	\$ 12.6	0.229	2.988	\$858.6	\$881.8	\$883.5	\$ 899.8
74	5.25%		\$818.0	\$856.6	\$ 909.8	\$ 12.3	0.232	3.063	\$837.3	\$860.0	\$861.8	\$ 877.4
74	16.50%		\$810.1	\$845.0	\$ 897.6	\$ 12.0	0.279	3.096	\$826.1	\$848.5	\$850.2	\$ 865.6
74	8.50%		\$792.1	\$827.1	\$ 878.3	\$ 11.8	0.275	3.058	\$808.6	\$830.5	\$832.2	\$ 847.5
75	10.00%		\$865.6	\$910.0	\$ 968.1	\$ 12.9	0.260	3.117	\$889.8	\$913.5	\$915.4	\$ 931.7
75	0.30%		\$867.5	\$906.8	\$ 969.5	\$ 12.9	0.258	3.085	\$886.8	\$910.3	\$912.3	\$ 928.8
75	10.50%		\$864.6	\$904.7	\$ 956.5	\$ 12.8	0.260	3.106	\$884.7	\$908.3	\$910.2	\$ 926.6
75	1.88%		\$852.4	\$890.3	\$ 945.0	\$ 12.6	0.239	2.996	\$870.7	\$893.8	\$895.6	\$ 911.8
75	13.00%		\$841.3	\$879.0	\$ 933.1	\$ 12.5	0.274	3.063	\$859.5	\$882.5	\$884.4	\$ 900.9
75	5.25%		\$820.0	\$857.1	\$ 908.0	\$ 12.2	0.226	3.055	\$837.9	\$860.5	\$862.3	\$ 877.6
75	16.50%		\$807.9	\$845.4	\$ 903.0	\$ 12.2	0.295	3.137	\$826.2	\$848.7	\$850.5	\$ 866.3
75	8.50%		\$788.8	\$827.2	\$ 883.8	\$ 11.9	0.260	3.052	\$808.6	\$830.5	\$832.3	\$ 847.8
76	10.00%		\$868.9	\$911.0	\$ 970.2	\$ 13.0	0.290	3.137	\$890.5	\$914.6	\$916.4	\$ 933.1
76	0.30%		\$867.4	\$907.8	\$ 961.6	\$ 12.8	0.277	3.083	\$887.7	\$911.4	\$913.2	\$ 929.9
76	10.50%		\$866.9	\$905.7	\$ 962.5	\$ 12.8	0.247	3.027	\$885.7	\$909.2	\$911.1	\$ 927.8
76	1.88%		\$854.1	\$891.1	\$ 945.6	\$ 12.7	0.304	3.142	\$871.4	\$894.6	\$896.5	\$ 912.7
76	13.00%		\$838.9	\$879.7	\$ 936.7	\$ 12.6	0.278	3.098	\$860.1	\$883.1	\$884.9	\$ 901.2
76	5.25%		\$823.1	\$862.2	\$ 912.2	\$ 12.3	0.291	3.110	\$843.1	\$865.7	\$867.5	\$ 883.4
76	16.50%		\$809.8	\$845.7	\$ 898.8	\$ 12.1	0.235	3.007	\$826.7	\$849.0	\$850.7	\$ 866.6
76	8.50%		\$787.6	\$827.4	\$ 878.0	\$ 11.8	0.229	3.001	\$808.9	\$830.7	\$832.4	\$ 847.7

**APPENDIX B: OPTIMAL COST AND DURATION SIMULATION AT
5TH AND 95TH PERCENTILE LEVEL**

Duration /Interest	5th Percentile Cost								
	0.00%	0.30%	0.50%	1.88%	3.00%	5.25%	6.50%	8.50%	
#1	60	\$962.90	\$960.58	\$958.90	\$947.66	\$938.88	\$921.91	\$912.62	\$898.15
	61	\$946.49	\$944.00	\$942.28	\$931.38	\$927.51	\$905.56	\$896.45	\$882.16
	62	\$935.21	\$933.03	\$931.24	\$919.79	\$911.11	\$893.68	\$884.36	\$869.79
	63	\$924.27	\$906.24	\$920.24	\$908.56	\$899.32	\$881.75	\$870.64	\$857.32
	64	\$908.84	\$906.24	\$904.41	\$892.34	\$882.83	\$864.42	\$854.56	\$845.12
	65	\$892.47	\$889.63	\$888.06	\$875.93	\$866.55	\$848.36	\$838.55	\$823.24
	66	\$893.42	\$890.75	\$888.88	\$876.81	\$866.94	\$848.34	\$838.34	\$822.68
	67	\$894.58	\$891.70	\$889.94	\$877.55	\$867.57	\$848.27	\$837.96	\$822.21
	68	\$895.64	\$892.73	\$890.86	\$878.07	\$868.11	\$848.35	\$837.98	\$821.64
	69	\$896.75	\$893.87	\$891.93	\$878.80	\$868.28	\$848.47	\$837.70	\$821.18
	70	\$897.85	\$894.78	\$893.02	\$879.46	\$868.96	\$848.60	\$837.69	\$820.67
	71	\$898.85	\$895.86	\$894.06	\$880.22	\$869.44	\$848.47	\$837.41	\$820.10
	72	\$900.05	\$896.82	\$894.87	\$881.07	\$870.10	\$849.04	\$837.75	\$820.35
	73	\$901.00	\$897.82	\$895.94	\$881.88	\$870.90	\$849.45	\$838.01	\$820.45
	74	\$902.08	\$898.91	\$896.88	\$882.65	\$871.58	\$849.96	\$838.45	\$820.64
	75	\$903.12	\$899.96	\$897.87	\$883.52	\$872.22	\$850.40	\$838.88	\$820.88
	76	\$904.14	\$900.82	\$898.91	\$884.32	\$872.95	\$855.57	\$839.15	\$820.95
Duration /Interest	5th Percentile Cost								
	0.00%	0.30%	0.50%	1.88%	3.00%	5.25%	6.50%	8.50%	
#2	60	\$959.77	\$957.51	\$955.52	\$944.54	\$935.75	\$918.67	\$909.44	\$895.28
	61	\$943.37	\$940.89	\$939.18	\$928.16	\$924.11	\$902.50	\$893.59	\$879.36
	62	\$932.36	\$929.96	\$927.96	\$916.89	\$908.14	\$890.71	\$881.40	\$867.17
	63	\$921.53	\$903.54	\$917.23	\$905.68	\$896.61	\$878.97	\$867.95	\$854.60
	64	\$906.02	\$903.54	\$901.75	\$889.73	\$880.26	\$861.94	\$851.88	\$842.44
	65	\$889.63	\$887.20	\$885.69	\$873.66	\$864.00	\$845.98	\$835.91	\$820.85
	66	\$890.82	\$888.19	\$886.56	\$874.06	\$864.50	\$845.80	\$835.89	\$820.19
	67	\$891.83	\$889.17	\$887.34	\$875.11	\$865.09	\$845.86	\$835.87	\$820.02
	68	\$893.24	\$890.36	\$888.34	\$875.73	\$865.57	\$846.18	\$835.60	\$819.36
	69	\$894.18	\$891.31	\$889.29	\$876.32	\$866.22	\$846.07	\$835.20	\$818.69
	70	\$895.28	\$892.43	\$890.43	\$877.17	\$866.67	\$846.06	\$835.24	\$818.29
	71	\$896.54	\$893.47	\$891.46	\$877.88	\$867.19	\$846.24	\$835.00	\$817.71
	72	\$897.61	\$894.61	\$892.59	\$878.66	\$867.82	\$846.78	\$835.52	\$818.09
	73	\$898.63	\$895.38	\$893.60	\$879.79	\$868.41	\$847.44	\$835.94	\$818.30
	74	\$899.68	\$896.42	\$894.41	\$880.51	\$869.32	\$847.79	\$836.14	\$818.45
	75	\$900.77	\$897.58	\$895.65	\$881.00	\$869.95	\$848.13	\$836.72	\$818.65
	76	\$901.68	\$898.66	\$896.57	\$882.05	\$870.73	\$853.43	\$837.04	\$818.90

Duration /Interest	5th Percentile Cost								
	0.00%	0.30%	0.50%	1.88%	3.00%	5.25%	6.50%	8.50%	
#3	60	\$954.83	\$952.55	\$950.90	\$939.47	\$930.88	\$913.78	\$904.50	\$890.46
	61	\$938.47	\$935.89	\$934.39	\$923.55	\$919.59	\$898.00	\$888.71	\$874.62
	62	\$927.44	\$925.23	\$923.26	\$912.26	\$903.09	\$886.16	\$877.26	\$862.31
	63	\$916.94	\$899.23	\$912.67	\$901.20	\$892.02	\$874.61	\$863.91	\$850.37
	64	\$901.65	\$899.23	\$897.70	\$885.44	\$876.10	\$858.04	\$848.15	\$838.45
	65	\$885.48	\$883.30	\$881.47	\$869.64	\$859.96	\$842.12	\$832.36	\$817.15
	66	\$886.96	\$884.26	\$882.41	\$870.28	\$860.59	\$841.98	\$832.13	\$816.63
	67	\$888.08	\$885.26	\$883.49	\$870.87	\$861.30	\$842.17	\$832.02	\$816.21
	68	\$889.24	\$886.44	\$884.65	\$872.05	\$861.77	\$842.27	\$831.62	\$815.65
	69	\$890.35	\$887.16	\$885.69	\$872.52	\$862.16	\$842.44	\$831.80	\$815.37
	70	\$891.47	\$888.69	\$886.49	\$873.31	\$862.85	\$842.56	\$831.50	\$814.73
	71	\$892.87	\$889.62	\$887.72	\$874.22	\$863.30	\$842.42	\$831.53	\$814.22
	72	\$893.88	\$890.80	\$888.71	\$874.91	\$864.17	\$843.30	\$831.86	\$814.55
	73	\$895.14	\$891.71	\$890.08	\$875.81	\$864.92	\$843.81	\$832.49	\$814.62
	74	\$896.05	\$892.90	\$890.89	\$876.86	\$865.85	\$844.44	\$832.69	\$815.18
	75	\$897.29	\$893.84	\$891.99	\$877.42	\$866.54	\$844.80	\$833.29	\$815.52
	76	\$897.97	\$894.79	\$893.03	\$878.59	\$867.38	\$849.84	\$833.65	\$815.66
Duration /Interest	5th Percentile Cost								
	0.00%	0.30%	0.50%	1.88%	3.00%	5.25%	6.50%	8.50%	
#4	60	\$944.42	\$942.00	\$939.88	\$929.71	\$920.95	\$903.69	\$894.50	\$880.76
	61	\$928.41	\$926.28	\$924.19	\$913.64	\$909.80	\$887.97	\$879.25	\$865.21
	62	\$918.45	\$915.46	\$914.34	\$902.55	\$893.81	\$877.17	\$867.85	\$853.73
	63	\$907.82	\$891.27	\$903.50	\$892.20	\$883.18	\$865.31	\$855.23	\$841.91
	64	\$893.12	\$891.27	\$889.58	\$877.13	\$867.97	\$850.10	\$839.53	\$830.20
	65	\$877.43	\$874.89	\$873.54	\$861.67	\$852.24	\$834.52	\$824.20	\$809.72
	66	\$879.23	\$876.35	\$874.49	\$862.50	\$853.04	\$834.41	\$824.27	\$809.58
	67	\$880.43	\$877.41	\$876.14	\$863.46	\$853.51	\$834.43	\$824.75	\$808.55
	68	\$881.64	\$878.52	\$877.21	\$864.55	\$854.45	\$834.97	\$824.64	\$808.59
	69	\$882.73	\$879.75	\$877.87	\$865.25	\$854.72	\$835.21	\$824.56	\$808.06
	70	\$884.15	\$881.13	\$879.33	\$866.20	\$855.49	\$835.38	\$824.72	\$807.90
	71	\$885.79	\$881.99	\$880.16	\$866.76	\$856.34	\$835.29	\$824.34	\$807.75
	72	\$886.23	\$883.43	\$881.56	\$867.94	\$856.75	\$836.22	\$824.93	\$808.10
	73	\$887.28	\$884.58	\$882.85	\$868.78	\$857.70	\$836.50	\$825.93	\$808.03
	74	\$888.84	\$885.87	\$883.62	\$869.55	\$858.63	\$837.30	\$826.10	\$808.58
	75	\$889.80	\$886.80	\$884.71	\$870.67	\$859.52	\$837.93	\$826.17	\$808.63
	76	\$890.53	\$887.67	\$885.68	\$871.42	\$860.10	\$843.10	\$826.66	\$808.90

Duration /Interest	95th Percentile Cost								
	0.00%	0.30%	0.50%	1.88%	3.00%	5.25%	6.50%	8.50%	
#1	60	\$ 983.24	\$ 980.44	\$ 978.96	\$ 967.46	\$ 958.71	\$ 941.12	\$ 931.88	\$ 917.25
	61	\$ 965.71	\$ 963.38	\$ 961.52	\$ 950.40	\$ 946.07	\$ 924.46	\$ 914.89	\$ 900.68
	62	\$ 953.82	\$ 951.13	\$ 949.44	\$ 938.24	\$ 929.06	\$ 911.40	\$ 901.82	\$ 887.23
	63	\$ 941.80	\$ 922.48	\$ 937.46	\$ 925.72	\$ 916.55	\$ 898.58	\$ 886.79	\$ 873.93
	64	\$ 925.09	\$ 922.48	\$ 920.70	\$ 908.41	\$ 898.77	\$ 879.99	\$ 869.97	\$ 860.78
	65	\$ 907.54	\$ 904.93	\$ 903.19	\$ 891.23	\$ 881.75	\$ 863.07	\$ 853.13	\$ 837.70
	66	\$ 908.76	\$ 906.12	\$ 904.28	\$ 891.76	\$ 881.93	\$ 863.01	\$ 852.76	\$ 837.01
	67	\$ 909.59	\$ 906.74	\$ 905.05	\$ 892.26	\$ 882.21	\$ 862.91	\$ 852.40	\$ 836.25
	68	\$ 910.36	\$ 907.63	\$ 905.68	\$ 892.69	\$ 882.47	\$ 862.55	\$ 852.02	\$ 835.43
	69	\$ 911.40	\$ 908.44	\$ 906.46	\$ 893.09	\$ 882.63	\$ 862.49	\$ 851.64	\$ 834.76
	70	\$ 912.19	\$ 909.16	\$ 907.18	\$ 893.78	\$ 882.94	\$ 862.30	\$ 850.97	\$ 833.95
	71	\$ 913.26	\$ 910.16	\$ 908.03	\$ 894.11	\$ 883.39	\$ 862.02	\$ 850.76	\$ 833.29
	72	\$ 914.03	\$ 910.88	\$ 909.07	\$ 895.02	\$ 884.03	\$ 862.65	\$ 851.07	\$ 833.36
	73	\$ 915.04	\$ 912.10	\$ 909.84	\$ 895.75	\$ 884.60	\$ 862.89	\$ 851.29	\$ 833.49
	74	\$ 916.06	\$ 912.78	\$ 910.93	\$ 896.47	\$ 885.15	\$ 863.47	\$ 851.62	\$ 833.69
	75	\$ 916.94	\$ 913.80	\$ 911.63	\$ 897.12	\$ 885.67	\$ 863.76	\$ 852.02	\$ 833.72
	76	\$ 917.84	\$ 914.66	\$ 912.61	\$ 898.08	\$ 886.43	\$ 868.98	\$ 852.18	\$ 833.85
Duration /Interest	95th Percentile Cost								
	0.00%	0.30%	0.50%	1.88%	3.00%	5.25%	6.50%	8.50%	
#2	60	\$ 987.47	\$ 985.01	\$ 983.11	\$ 971.98	\$ 962.75	\$ 945.45	\$ 936.09	\$ 921.39
	61	\$ 970.17	\$ 967.44	\$ 965.81	\$ 954.75	\$ 950.44	\$ 928.23	\$ 919.15	\$ 904.84
	62	\$ 957.63	\$ 955.45	\$ 953.30	\$ 942.00	\$ 932.98	\$ 914.97	\$ 905.74	\$ 891.02
	63	\$ 945.74	\$ 926.13	\$ 941.20	\$ 929.50	\$ 920.65	\$ 902.63	\$ 890.36	\$ 877.94
	64	\$ 928.77	\$ 926.13	\$ 924.10	\$ 912.06	\$ 902.48	\$ 883.53	\$ 873.33	\$ 864.11
	65	\$ 911.39	\$ 908.48	\$ 906.84	\$ 894.49	\$ 884.92	\$ 866.29	\$ 856.32	\$ 840.77
	66	\$ 911.85	\$ 909.29	\$ 907.37	\$ 895.05	\$ 885.21	\$ 866.08	\$ 855.85	\$ 840.11
	67	\$ 912.80	\$ 910.31	\$ 908.25	\$ 895.42	\$ 885.59	\$ 865.88	\$ 855.33	\$ 839.23
	68	\$ 913.83	\$ 910.68	\$ 909.03	\$ 895.73	\$ 885.76	\$ 865.77	\$ 855.08	\$ 838.43
	69	\$ 914.79	\$ 911.74	\$ 909.83	\$ 896.45	\$ 885.67	\$ 865.41	\$ 854.45	\$ 837.87
	70	\$ 915.44	\$ 912.35	\$ 910.49	\$ 896.61	\$ 885.96	\$ 865.10	\$ 854.14	\$ 836.86
	71	\$ 916.44	\$ 913.06	\$ 911.28	\$ 897.28	\$ 886.34	\$ 865.38	\$ 853.65	\$ 836.10
	72	\$ 917.24	\$ 913.96	\$ 912.15	\$ 898.27	\$ 886.76	\$ 865.40	\$ 853.91	\$ 836.02
	73	\$ 918.21	\$ 914.92	\$ 912.78	\$ 898.57	\$ 887.66	\$ 865.96	\$ 854.28	\$ 836.29
	74	\$ 918.95	\$ 916.12	\$ 913.89	\$ 899.26	\$ 888.04	\$ 866.13	\$ 854.62	\$ 836.31
	75	\$ 919.99	\$ 916.74	\$ 914.55	\$ 900.18	\$ 888.93	\$ 866.78	\$ 854.80	\$ 836.41
	76	\$ 920.93	\$ 917.56	\$ 915.58	\$ 900.85	\$ 889.43	\$ 871.93	\$ 855.17	\$ 836.68

Duration /Interest	95th Percentile Cost								
	0.00%	0.30%	0.50%	1.88%	3.00%	5.25%	6.50%	8.50%	
#3	60	\$ 994.26	\$ 991.22	\$ 989.69	\$ 979.01	\$ 969.48	\$ 951.75	\$ 942.61	\$ 927.38
	61	\$ 976.62	\$ 973.69	\$ 972.34	\$ 961.10	\$ 956.34	\$ 934.54	\$ 925.26	\$ 910.80
	62	\$ 964.01	\$ 961.61	\$ 960.00	\$ 948.16	\$ 938.95	\$ 921.06	\$ 911.69	\$ 897.04
	63	\$ 951.32	\$ 931.18	\$ 946.83	\$ 935.31	\$ 925.91	\$ 907.74	\$ 895.73	\$ 883.36
	64	\$ 934.01	\$ 931.18	\$ 929.80	\$ 917.28	\$ 907.39	\$ 888.52	\$ 878.29	\$ 869.49
	65	\$ 916.30	\$ 913.46	\$ 911.93	\$ 899.81	\$ 889.87	\$ 871.30	\$ 861.20	\$ 845.63
	66	\$ 916.84	\$ 914.48	\$ 912.22	\$ 900.21	\$ 890.44	\$ 870.76	\$ 860.63	\$ 844.64
	67	\$ 917.64	\$ 914.67	\$ 913.20	\$ 900.23	\$ 890.25	\$ 870.53	\$ 860.27	\$ 844.09
	68	\$ 918.52	\$ 915.43	\$ 913.89	\$ 900.34	\$ 890.65	\$ 870.49	\$ 859.66	\$ 843.06
	69	\$ 919.19	\$ 916.53	\$ 914.07	\$ 901.27	\$ 890.43	\$ 869.99	\$ 859.21	\$ 842.31
	70	\$ 919.77	\$ 917.13	\$ 915.23	\$ 901.49	\$ 890.42	\$ 870.00	\$ 858.61	\$ 841.12
	71	\$ 920.96	\$ 918.07	\$ 915.81	\$ 901.94	\$ 890.87	\$ 869.97	\$ 858.10	\$ 840.29
	72	\$ 921.83	\$ 918.75	\$ 916.83	\$ 902.24	\$ 891.61	\$ 869.69	\$ 858.62	\$ 840.73
	73	\$ 922.90	\$ 919.83	\$ 917.35	\$ 903.38	\$ 892.03	\$ 870.38	\$ 858.64	\$ 840.92
	74	\$ 923.85	\$ 920.51	\$ 918.25	\$ 903.96	\$ 892.39	\$ 870.71	\$ 858.83	\$ 840.49
	75	\$ 924.71	\$ 921.09	\$ 919.44	\$ 904.66	\$ 893.26	\$ 871.07	\$ 859.06	\$ 840.46
	76	\$ 925.34	\$ 922.14	\$ 920.12	\$ 905.53	\$ 893.87	\$ 875.96	\$ 859.59	\$ 840.57
Duration /Interest	95th Percentile Cost								
	0.00%	0.30%	0.50%	1.88%	3.00%	5.25%	6.50%	8.50%	
#4	60	\$ 1,005.19	\$ 1,002.18	\$ 1,000.76	\$ 989.28	\$ 979.91	\$ 962.55	\$ 952.46	\$ 937.93
	61	\$ 987.36	\$ 984.25	\$ 982.57	\$ 971.35	\$ 966.01	\$ 944.57	\$ 935.07	\$ 920.54
	62	\$ 973.59	\$ 971.35	\$ 969.81	\$ 958.55	\$ 949.24	\$ 930.97	\$ 921.22	\$ 906.18
	63	\$ 960.69	\$ 939.38	\$ 956.70	\$ 944.83	\$ 935.10	\$ 917.00	\$ 904.28	\$ 892.02
	64	\$ 942.63	\$ 939.38	\$ 938.54	\$ 925.89	\$ 915.71	\$ 896.96	\$ 886.98	\$ 877.62
	65	\$ 923.97	\$ 921.78	\$ 919.76	\$ 907.91	\$ 897.86	\$ 878.89	\$ 868.61	\$ 852.89
	66	\$ 924.60	\$ 922.43	\$ 920.64	\$ 908.11	\$ 897.66	\$ 878.16	\$ 868.33	\$ 852.58
	67	\$ 925.88	\$ 922.84	\$ 921.37	\$ 908.44	\$ 898.11	\$ 878.23	\$ 867.76	\$ 851.91
	68	\$ 926.72	\$ 923.84	\$ 921.54	\$ 908.69	\$ 898.05	\$ 878.03	\$ 866.76	\$ 850.35
	69	\$ 926.97	\$ 924.75	\$ 922.52	\$ 908.83	\$ 898.29	\$ 876.93	\$ 866.58	\$ 849.26
	70	\$ 927.74	\$ 925.13	\$ 922.76	\$ 909.15	\$ 898.04	\$ 876.99	\$ 865.61	\$ 848.56
	71	\$ 928.81	\$ 925.50	\$ 923.09	\$ 909.26	\$ 898.13	\$ 876.57	\$ 865.67	\$ 847.36
	72	\$ 929.68	\$ 926.01	\$ 924.19	\$ 909.99	\$ 898.66	\$ 877.28	\$ 865.63	\$ 847.51
	73	\$ 929.54	\$ 926.76	\$ 924.48	\$ 910.53	\$ 899.50	\$ 877.49	\$ 865.70	\$ 847.63
	74	\$ 931.01	\$ 927.48	\$ 926.04	\$ 911.35	\$ 899.82	\$ 877.41	\$ 865.64	\$ 847.55
	75	\$ 931.74	\$ 928.79	\$ 926.63	\$ 911.76	\$ 900.86	\$ 877.65	\$ 866.30	\$ 847.83
	76	\$ 933.07	\$ 929.87	\$ 927.79	\$ 912.71	\$ 901.22	\$ 883.41	\$ 866.57	\$ 847.68

APPENDIX C: BETAGENERAL DISTRIBUTION

Description	<p><i>RiskBetaGeneral</i>($\alpha_1, \alpha_2, \text{minimum}, \text{maximum}$) specifies a beta distribution with the defined <i>minimum</i> and <i>maximum</i> using the shape parameters α_1 and α_2.</p> <p>The BetaGeneral is directly derived from the Beta distribution by scaling the [0,1] range of the Beta distribution with the use of a minimum and maximum value to define the range. The PERT distribution can be derived as a special case of the BetaGeneral distribution.</p>
Examples	<p>RiskBetaGeneral(1,2,0,100) specifies a beta distribution using the shape parameters 1 and 2 and a minimum value of 0 and a maximum value of 100.</p> <p>RiskBetaGeneral(C12,C13,D12,D13) specifies a beta distribution using the shape parameter α_1 taken from cell C12 and a shape parameter α_2 taken from cell C13 and a minimum value from D12 and a maximum value of from D13.</p>
Guidelines	<p>α_1 continuous shape parameter $\alpha_1 > 0$</p> <p>α_2 continuous shape parameter $\alpha_2 > 0$</p> <p>min continuous boundary parameter min < max</p> <p>max continuous boundary parameter</p>
Domain	min ≤ x ≤ max continuous
Density and Cumulative Distribution Functions	$f(x) = \frac{(x - \text{min})^{\alpha_1 - 1} (\text{max} - x)^{\alpha_2 - 1}}{B(\alpha_1, \alpha_2) (\text{max} - \text{min})^{\alpha_1 + \alpha_2 - 1}}$ $F(x) = \frac{B_z(\alpha_1, \alpha_2)}{B(\alpha_1, \alpha_2)} \equiv I_z(\alpha_1, \alpha_2) \quad \text{with } z \equiv \frac{x - \text{min}}{\text{max} - \text{min}}$ <p>where B is the Beta Function and B_z is the Incomplete Beta Function.</p>
Mean	$\text{min} + \frac{\alpha_1}{\alpha_1 + \alpha_2} (\text{max} - \text{min})$
Variance	$\frac{\alpha_1 \alpha_2}{(\alpha_1 + \alpha_2)^2 (\alpha_1 + \alpha_2 + 1)} (\text{max} - \text{min})^2$
Skewness	$2 \frac{\alpha_2 - \alpha_1}{\alpha_1 + \alpha_2 + 2} \sqrt{\frac{\alpha_1 + \alpha_2 + 1}{\alpha_1 \alpha_2}}$
Kurtosis	$3 \frac{(\alpha_1 + \alpha_2 + 1) (2(\alpha_1 + \alpha_2)^2 + \alpha_1 \alpha_2 (\alpha_1 + \alpha_2 - 6))}{\alpha_1 \alpha_2 (\alpha_1 + \alpha_2 + 2) (\alpha_1 + \alpha_2 + 3)}$

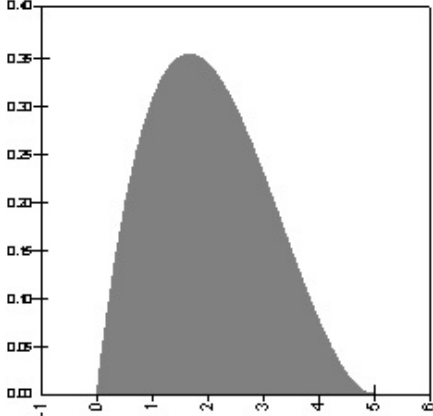
<p>Mode</p>	$\min + \frac{\alpha_1 - 1}{\alpha_1 + \alpha_2 - 2} (\max - \min)$ <p>$\alpha_1 > 1, \alpha_2 > 1$</p> <p>min $\alpha_1 < 1, \alpha_2 \geq 1$ or $\alpha_1 = 1, \alpha_2 > 1$</p> <p>max $\alpha_1 \geq 1, \alpha_2 < 1$ or $\alpha_1 > 1, \alpha_2 = 1$</p>
<p>Examples</p>	<p>PDF - BetaGeneral(2,3,0,5)</p>  <p>CDF - BetaGeneral(2,3,0,5)</p> 