

國立交通大學

應用化學研究所

博士論文

便利的醣質反應策略製備含 β -甘露糖之寡醣體及

芳香族立體選擇醣質反應與其應用性



Convenient Glycosylation Strategy for Preparation of
Oligosaccharides with β -Mannosidic bonds & Stereoselective Aryl
Glycosylations and Its Applications Thereof

研究生：張世聖 撰

指導教授：蒙國光教授、李耀坤教授

中華民國九十八年九月

便利的醣質反應策略製備含 β -甘露糖之寡醣體及

芳香族立體選擇醣質反應與其應用性

Convenient Glycosylation Strategy for Preparation of
Oligosaccharides with β -Mannosidic bonds & Stereoselective
Aryl Glycosylations and Its Applications Thereof

研究生：張世聖 撰

Graduate Student : Shih-Sheng Chang

指導教授：蒙國光教授、李耀坤教授

Thesis advisor : Assist. Prof. Kowk-Kong Tony Mong, Prof. Yaw-Kuen Li

國立交通大學
應用化學研究所
博士論文

A Thesis

Submitted to Department of Applied Chemistry

College of Science

National Chiao Tung University, Taiwan

in partial Fulfillment of the Requirements

for the Degree of

Doctor of Science In Applied Chemistry

June 2009

Hsin-chu, Taiwan, Republic of China

中華民國九十八年九月

摘要

本論文主要分為兩大部份：

1. 本論文第一部份係運用逆加成程序進行一有效力 orthogonal β -甘露糖質反應。此一新的糖質化反應合成程序，運用已研發有效力之階段式合成策略，以快速生合成出 *N*-linked glycoproteins 糖蛋白之核心三糖體 $\text{Man-}\beta(1,4)\text{-GlcNAc-}\beta(1,4)\text{-GlcNAc}$ 與沙門氏菌細胞囊膜之單位三糖體 $\text{Man-}\beta(1,4)\text{-Rha-}\alpha(1,3)\text{-Gal}$ 。
2. 第二部份運用一簡便的三氯乙醯氨絡化物乙醯化基糖予體進行實用且有效力的控制 α -立體選擇性 aromatic 糖質反應。此合成方法特別對三氯乙醯氨絡化物 L-岩藻糖予體與 2-azido-2-deoxy-D-半乳糖予體更有效獲得主要 α -立體選擇性產物，此一合成方法的通用性已加以論證：(1) 已生合成獲得立體專一性化合物 4-methylumbelliferyl α -T-antigen 加以論證、(2) 有效率的合成出 L-岩藻糖基質小分子庫、(3) 使用 L-岩藻糖基質分子庫研究解釋 L-岩藻糖酶的反應機構。

Abstract

The first part of thesis reports the first effective orthogonal β -mannosylation method by adopting an optimized inverse-addition procedure. This new glycosylation procedure enables the development of sequential strategy for synthesis of trisaccharide core of *N*-linked glycoproteins, Man- β (1,4)-GlcNAc- β (1,4)-GlcNAc and trisaccharide unit of bacterial capsule in Salmonella bacteria, Man- β (1,4)-Rha- α (1,3)-Gal.

The second part of thesis describes a practical and efficient α -selective aromatic glycosylation. The method employs easily available per-*O*-acetyl glycopyranosyl imidate donors and tedious protecting group manipulations are not required. It is particularly effective for L-fucopyranosyl and 2-azido-2-deoxy-D-galatosamine donors, glycosylations with which produce exclusive α -selectivity. Practical utilities of this method were demonstrated in: (1) stereoselective synthesis of biological relevant 4-methylumbelliferyl α -T-antigen; (2) efficient synthesis of small libraries of aryl α -L-fucopyranosides and their subsequent use for elucidation of reaction mechanisms of human L-fucosidase.

謝 誌

博士五年的學習生涯，隨著口試合格與論文完成終於告一段落，首先要感謝吾師 蒙國光 教授與 李耀坤教授在這五年裏對學生的細心教導與栽培，一路教導叮嚀學生學習實驗的技巧與專業知識的吸收，讓學生得已順利獲得博士學位。另外，感謝林俊成 教授、吳東昆 教授於課業上細心教導學生，讓學生在準備專業領域論文之外學習到更多的生化與有機合成化學領域的知識。

感謝林俊成 教授、林俊宏 教授、李耀坤 教授與吳東昆 教授於百忙之中撥空擔任學生博士論文口試委員，由於老師們對論文內容的建議與指導，讓學生所寫作的論文更具完整專業性，感謝交通大學、中央研究院、國科會於經費與儀器上的資助。

感謝我的家人給我的鼓勵與關懷，特別感謝吾妻莞勳，總是在背後支持著我，謝謝妳一路陪我及給我妳全部的愛。

感謝摯愛的父、母親，張均宏先生、黃婁媚女士對我的栽培與養育在此將本論文完成的所有成就獻給你們。

簡寫表

Ac	acetyl
Ac ₂ O	acetic anhydride
Bn	benzyl
Bz	benzoyl
Cp	cyclopentadienyl
DBU	1,8-diazabicyclo[5.4.0]undec-7-ene
DMF	<i>N,N</i> -dimethylformamide
DMAP	4-(<i>N,N</i> -dimethylamino)pyridine
DMTP	dimethyl thiophenyl
DTBS	di-(<i>tert</i> -butyl)silylidene acetal
DTBMP	di-(<i>tert</i> -butyl) methyl pyridine
Et	ethyl
Gal	galactose
Glc	Glucose
HIV	Human immunodeficiency virus
Man	mannose
mAb	mono antibodies
Me	methyl
MS	molecular sieve
NIS	<i>N</i> -iodosuccinimide
Ph	phenyl

Phth	phthaloyl
Pyr	pyridine
Piv	pivaloyl
Pr	<i>n</i> -propyl
PMB	<i>p</i> -methoxy benzyl
Ser	Serine
TBDMS	(<i>tert</i> -butyl)-dimethyl-silylidene acetal
TMSOTf	trimethylsilyl trifluoromethanesulfonate
STol	Thiocresol
TsOH	<i>p</i> -toluenesulfonic acid H ₂ O
TES	triethylsilane
TFA	trifluoroacetic acid
Tf	Trifluoromethanesulfonate
Tf ₂ O	Trifluoromethanesulfonate anhydride
THF	tetrahydrofuran
TBAB	tetra- <i>n</i> -butylammonium bromide
Thr	Threonine
TTBP	tri-(<i>tert</i> -butyl) pyridine
Troc	2,2,2-trichloroethoxycarbonyl

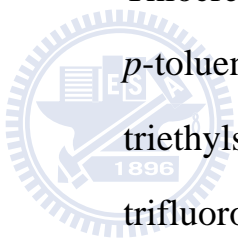

目 錄

摘 要		I
Abstract		II
謝 誌		III
簡寫表		IV-V
目 錄		VI-X
第一部份	便利的醣質反應策略製備含 β -甘露醣之寡醣體	1
第一章	緒 論	1
1.1	前 言	1
1.2	研究動機	2
1.3	β -鍵結-甘露醣之寡醣體蛋白脂質簡介	3-7
1.4	一鍋化之寡醣體醣質化反應合成簡介	7-15
1.5	β -鍵結-甘露醣之離去官能基合成應用介紹	15-21
第二章	結果與討論	22
2.1	一鍋化醣質反應合成核心三醣體之探討	22
2.1.1	Sufoxide、thiophenyl 醣體離去基進行一鍋化三醣體醣質合成反應之運用	22-33
2.1.2	Trichloroacetimidate、2,6-dimethylthiophenyl 醣體離去基進行一鍋化三醣體醣質合成反應之運用	33-36
2.1.3	運用速率逆加成程序法控制 β -甘露醣醣質鍵結之寡醣體一鍋化合成與應用	37-43
2.2	結 論	44-45
第三章	實驗部份	46
3.1	一般實驗	46

3.2	實驗	47
3.2.1	一般實驗步驟	47
3.2.1.1	使用 DPSO 進行 β -Mannosylation	47
3.2.1.2	運用 sulfoxides 醣予體額外加入 DPSO 進行一鍋化三醣體反應	48
3.2.1.3	運用 trichloroacetimidate 醣予體使用劑量 TMSOTf 進行 β -Mannosylation	49
3.2.1.4	運用 mannosyl acetimidate 醣予體進行階段式醣質反應合成三醣體	50
3.2.1.5	1,2- <i>trans</i> β -selective 低濃度醣質反應	51
3.2.1.6	運用 inverse-addition procedure 製備 β -mannosidic bonds	51-52
3.2.1.7	運用階段式醣質反應策略製備含 β -mannosidic bonds 之寡醣體	52-53
3.2.1.8	去乙縮醛反應步驟	53
3.2.2.2	製備單醣體基材反應步驟	53-78
第二部份	芳香族立體選擇醣質反應與其應用性	
第四章	緒論	79
4.1	前言	79
4.1.1	α -L-岩藻醣與 α -L-岩藻醣苷水解酶之重要性簡介	79-80
4.2	研究動機	80-82
4.3	α -L-岩藻醣苷水解酶之水解反應催化機制簡介	82-84
4.4	α -L-岩藻醣及其醣基質之醣質化反應合成簡介	84-91
第五章	結果與討論	92
5.1	製備 α -L-岩藻醣基質醣質合成反應之探討	92-95
5.2	PNP 與 per- <i>O</i> -acetyl glycosyl imidates 醣質合成反應	95-97

5.3	4-MU α -T-antigen 之醣質合成反應與應用	97-98
5.4	反應機構推論	99-100
5.5	結 論	101
第六章	實驗部份	102
6.1	實驗	102
6.1.1	一般實驗	102
6.1.2	一般實驗步驟	103-104
6.2	Phenyl 2,3,4- <i>O</i> -triacetyl-L-fucopyranoside 27, 38-44	104-108
6.3	<i>p</i> -Nitrophenyl per- <i>O</i> -acetyl-glycopyranosides 51, 54-57	109-112
6.4	Methylumbelliferyl 3,4,6-tri- <i>O</i> -acetyl-2-azido-2-deoxy- α -D-galactopyranoside 58	112
6.5	4-Methylumbelliferyl 2-azido-4,6- <i>O</i> -benzylidene-2-deoxy- α -D-galactopyranoside 59	113
6.6	4-Methylumbelliferyl 2-azido-4,6-di- <i>O</i> -benzylidene-2-deoxy-3-(2',3',4',6'-tetra- <i>O</i> -acetyl- β -D-galactopyranosyl)- α -D-galactopyranoside 60	114
6.7	4-Methylumbelliferyl (4-MU) 2-acetamido-2-deoxy-3-(β -D-galactopyranosyl)- α -D-galactopyranoside 24	115-1116
	參考文獻	117-125
	附 錄	126-227
圖表流程目錄		
	圖一 β -鍵結-甘露糖之寡糖體脂質結構	1
	圖二 一鍋化 <i>N</i> -linked glycan 三糖體醣質化反應	3
	圖三 Human immunodeficiency virus	6
	圖四 寡糖五糖體核心結構	22

圖五	Sulfoxide β -鍵結甘露醣體醣質之反應機構	26
圖六	DPSO β -鍵結甘露醣體醣質之反應機構	26
圖七	防止醣體配位基轉移之反應機構	27
圖八	Globo-H、KH-1 醣類抗原	80
圖九	2-取代基芳香醇化合物分子間氫鍵作用力	95
表一	Crich β -甘露醣醣質反應合成	16
表二	Schmidt β -甘露醣醣質反應合成	17
表三	Seeberger β -甘露醣醣質反應合成	20
表四	Kim β -甘露醣醣質反應合成	21
表五	β -鍵結甘露醣體醣質反應合成運用	24
表六	Sulfoxide agent 之 β -鍵結甘露醣體醣質反應合成運用	25
表七	路易士酸量控制 β -甘露醣鍵結主要產物之運用	34
表八	速率逆加成程序法控制 β -甘露雙醣體醣質鍵結	37
表九	速率逆加成程序法控制 β -甘露雙醣體醣質鍵結	38
表十	PNP 與 fucopyranosyl imidate 26 醣質合成反應條件	93
表十一	制備 aryl α -L-fucopyranosides substrates	94
表十二	PNP 與 per- <i>O</i> -acetyl glycosyl imidates 醣質合成反應	96
流程一	一鍋化高甘露寡醣醣質反應合成	5
流程二	Ag-silicate 五醣體醣質化反應合成	7
流程三	一鍋化之寡醣體醣質化反應合成策略 A	8

流程四	策略 A 一鍋化之反應活性選擇醣質化反應合成	10
流程五	一鍋化之寡醣體醣質化反應合成策略 B	11
流程六	策略 B 一鍋化之幾何性醣質化反應合成	12
流程七	一鍋化之寡醣體醣質化反應合成策略 C	13
流程八	策略 C 一鍋化之階段性醣質化反應合成	14
流程九	Schmidt 逆加成醣質合成反應機構	18
流程十	Ito β -甘露醣醣質反應合成	19
流程十一	Kim β -甘露醣醣質合成反應機構	21
流程十二	一鍋化醣體之 HPLC-UV 分析數據	28
流程十三	一鍋化醣體之 HPLC-UV 分析數據	29
流程十四	一鍋化三醣體核心結構合成	31
流程十五	一鍋化三醣體結構合成	32
流程十六	DMTP 硫化物離去基防止醣體配位基轉移	33
流程十七	TMSOTf 酸量控制之一鍋化三醣體醣質反應合成運用	35
流程十八	TMSOTf 酸量控制之一鍋化三醣體醣質反應合成運用	36
流程十九	控制速率逆加成程序法之一鍋化三醣體醣質反應合成運用	39
流程二十	控制速率逆加成程序法之雙醣體醣質反應合成	40
流程二十一	控制速率逆加成程序法之一鍋化三醣體醣質反應合成應用	41
流程二十二	速率逆加成-甘露雙醣體合成反應機構	42

流程二十三	α -L-岩藻糖基質之糖質化反應合成與應用	82
流程二十四	α -L-岩藻糖苷水解酶反應機制	83
流程二十五	乙醯保護修飾 α -L-岩藻糖基質之糖質化反應	84
流程二十六	α -L-岩藻糖及其糖基質之 Koenigs-Knorr 糖質化反應	85
流程二十七	α -L-岩藻糖及其糖基質之 Koenigs-Knorr 糖質化反應	86
流程二十八	Koenigs-Knorr 名反應之 1,2 逆式糖質化反應機制	87
流程二十九	鹵化糖予體之 1,2-順式糖質化反應機制	88
流程三十	α -L-岩藻糖及其糖基質之硫化物糖予體糖質化反應	89
流程三十一	硫化物糖予體之糖質化反應機制	90
流程三十二	α -L-岩藻糖之三氯乙醯氨絡化物糖予體糖質化反應	91
流程三十三	制備 per- <i>O</i> -acetyl L-fucopyranosyl imidate 26	92
流程三十四	4-MU α -T-antigen 之糖質合成反應	98
流程三十五	α -selective aromatic 糖質合成反應機構推論	100

第一部份 便利的醣質反應策略製備含 β -甘露糖之寡醣體

第一章 緒論

1.1 前言

近代以有機合成化學的方式，生合成出自然界中寡醣體 (oligosaccharides) 的技術已經發展成熟，它是一件艱辛又精細的工作。除了要製備出多種化學合成路徑繁雜冗長的單醣體基材 (monosaccharide building blocks) 之外，還需要有效控制在醣體間醣質化反應中立體化學與位向化學 (stereo- and regio-selective) 的選擇性。在現今已開發的眾多寡醣體有機化學合成中，仍然缺乏一共通適用而有效率的醣質化反應合成技術，來應用於自然界中所有種類的寡醣體合成。^[1] 而含有 β -鍵結-甘露糖 (β -mannosidic bond containing oligosaccharides) 之寡醣體 (圖一) 合成就是一個很好的例子。

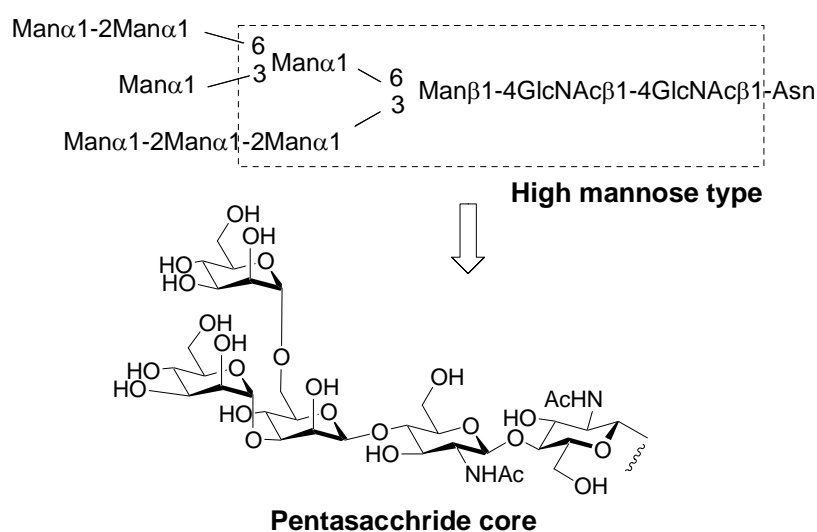

圖一、 β -鍵結-甘露糖之寡醣體脂質結構

1.2 研究動機

直至目前為止，以有機化學合成技術合成出含 β -鍵結-甘露糖之寡糖體，所需要克服的難題有以下幾點：繁雜冗長的單糖體基材合成、糖體間糖質化反應立體與位向的控制困難、糖質化逐步反應的純化不易(glycosylation of stepwise)、最終寡糖體合成產物之去保護基(deprotection)與水解寡糖體產物純化上困難、雙糖與雙糖體以上之多糖體鑑定難度。^[2]嘗試以一鍋化糖質反應法，解決所面臨的各種問題、將各糖質化反應條件最優化與縮短製備所需時間，為本主題研究主軸。

本主題主要之研究設計方向(圖二)，係以寡糖體中具 β -鍵結的甘露糖與 *N*-乙醯葡萄糖胺(*N*-acetamido glucosamine)之核心三糖體(*N*-linked glycan trisaccharide core)為合成標的物，預先將各單糖體上-OH 官能基各別修飾成不同種類的保護官能基，以便獲得三糖體後所需進行的位向選擇性控制，再將各糖體 1-OH 位置修飾成化學活性不同的離去官能基(leaving group)，利用各糖體間離去基反應活性不同的特性，設計以一鍋化反應的方式來取代困難又耗時的傳統逐步式糖質化反應。

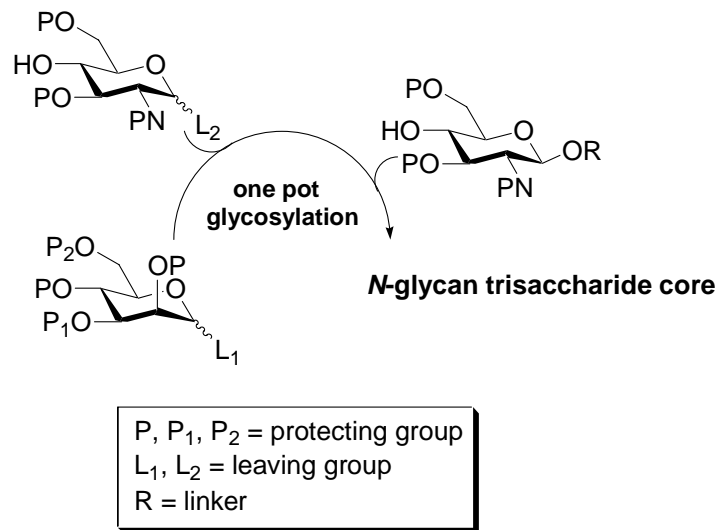

圖二、一鍋化 *N*-glycan 三醣體醣質化反應

1.3 β-鍵結-甘露糖之寡醣體蛋白脂質簡介

在過去幾年的研究證據顯示，多醣體蛋白脂質 (*N*-glycans of glycoproteins) 在生物活性中扮演著非常重要的角色，對增加了解其生理機能性質規則、分子機制，進而鑑定多醣體蛋白脂質相對重要。在自然界中醣蛋白質之間，主要以 *O*-醣基鍵 (*O*-linked glycosidic) 與氨基酸中的絲氨酸或息寧氨酸 (Threonine) 鍵結，而 *N*-醣基鍵 (*N*-linked glycosidic) 則與天門冬氨酸 (Asparagines) 鍵結。^[3]

β-鍵結-甘露糖之寡醣脂質蛋白；高甘露糖型 (High-mannose type)，其五醣核心結構，含括兩個α-鍵結甘露糖、兩個β-鍵結 *N*-乙酰葡萄糖胺、一個β-鍵結甘露糖等醣體鍵結，這些寡醣經由 *N*-鍵結鍵結於蛋白質上(圖一)。

mAb 2G12 (人類單株抗體 2G12),^[4]被發現不尋常的具有辨識 GP120 HIV-1 (Human immunodeficiency virus) 蛋白質上所共軛高甘露糖叢聚體 (Oligomannose cluster residues) 的能力。^[5] Wong 研究團隊亦以此高甘露寡糖為合成標的物,以糖體活性高低的合成概念進行一鍋化合成(流程一)(圖三)。^[6] 所獲得各類高甘露寡糖類似物再進行生物活性分析,加以釐清了解 mAb 2G12 抗體對高甘露糖的辨識活性結構為何。

其合成法運用性缺點;繁雜及耗時的糖體建構積塊修飾合成途徑、易產生自身縮合旁反應物 (self-condensation)。在我們的一鍋化實驗設計中,也針對了如何避開發生自身縮合旁反應的發生,及設計以運用重覆性高糖體中間體當糖體基材進而減少修飾合成步驟,加以縮短製備單糖體基材所需時間。

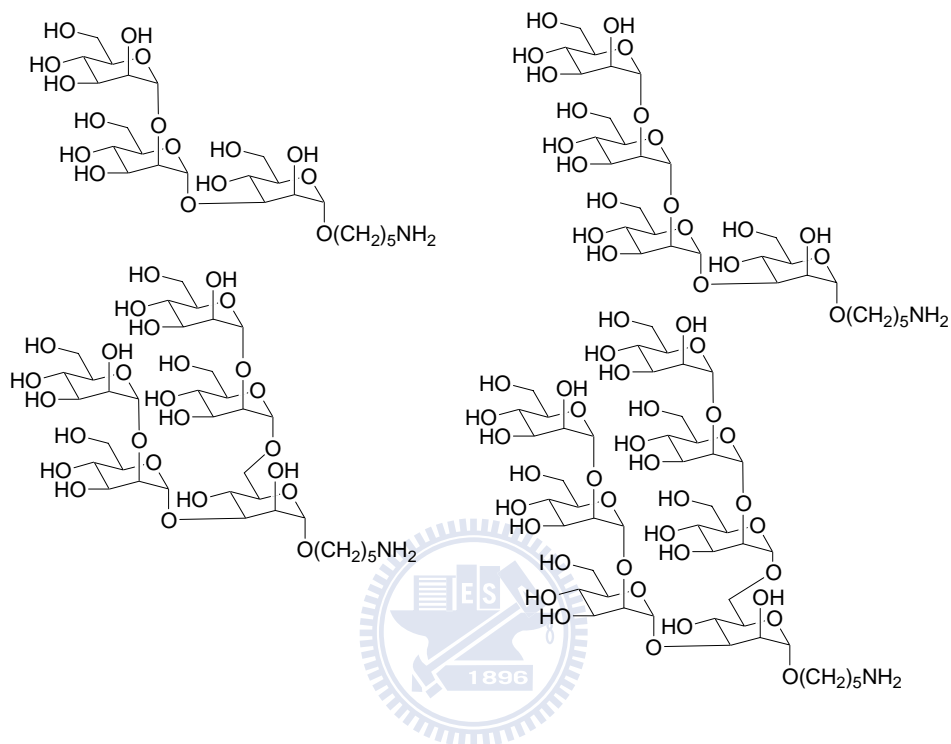
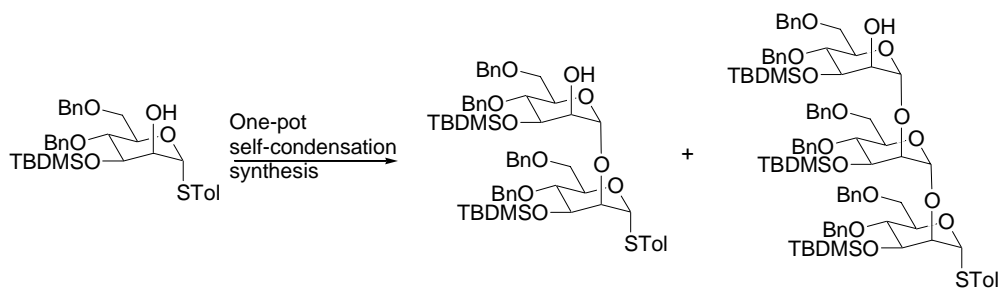

流程一、一鍋化高甘露寡糖糖質反應合成

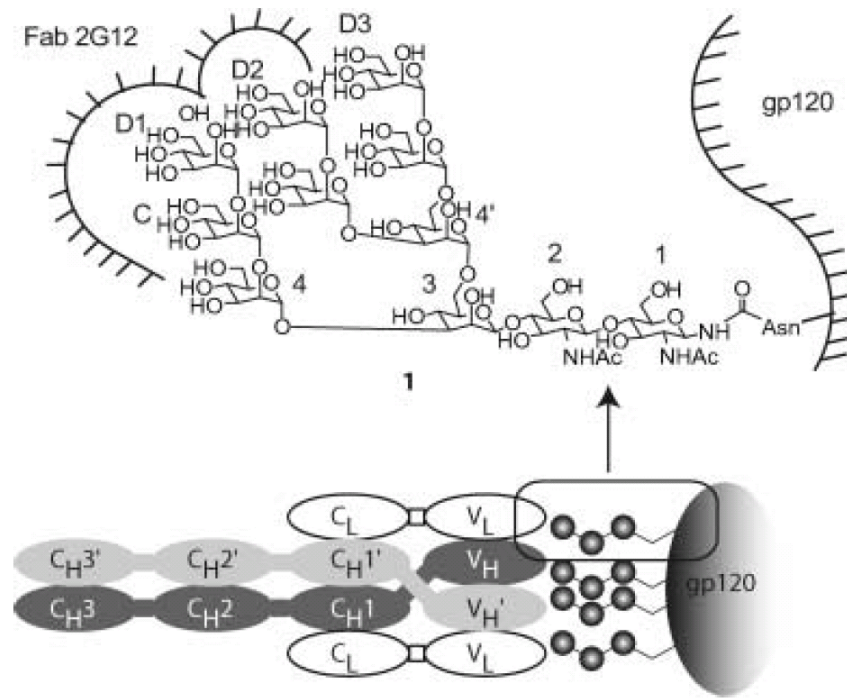

圖三、Human immunodeficiency virus

早期在1982年由Paulsen, H.以"不溶性"銀化物矽膠(Silver silicate)製備 β -甘露糖鍵結主要產物，係利用不溶性銀化鹽類固體表面催化進行控制 β -鍵結甘露糖的立體化學合成，進而合成出寡糖體五糖核心結構(流程二)。[7]

其合成法運用性缺點；因使用傳統逐步線性合成(linear synthesis)途徑，每一合成步驟均需要操作繁雜及耗時的中和、純化與鑑定實驗工作、其條件所獲得 β -甘露糖鍵結產物並非唯一產物，在純化及鑑定上有相當難度。而我們所運用"一鍋化糖質反應合成"與"Crich β -甘露糖鍵結條件"，可加以改善，期望得到比過往研究更快速、提高 β -鍵結甘露糖體選擇性與產率之合成途徑。

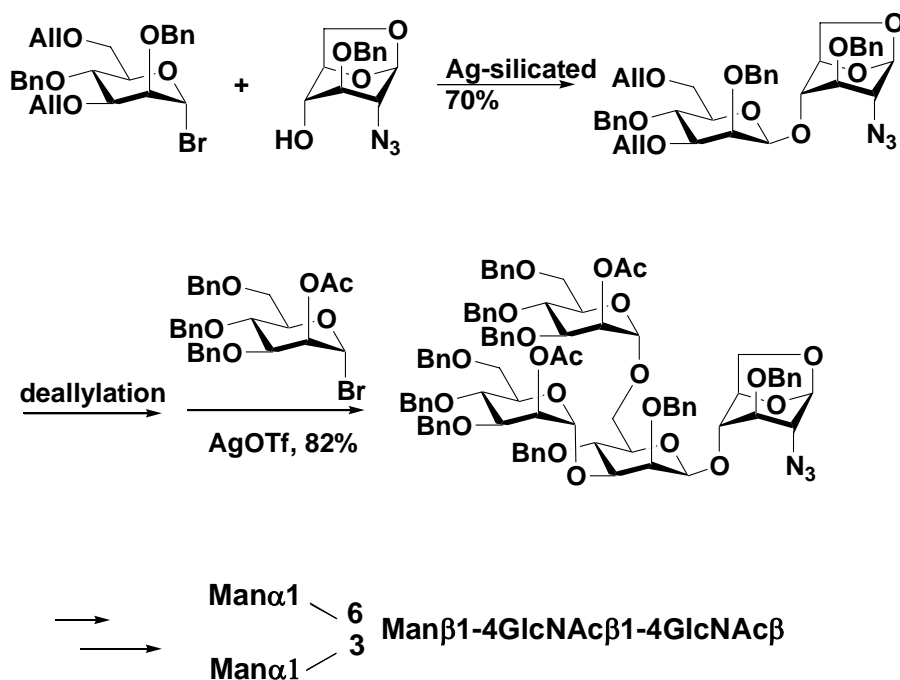

流程二、Ag-silicate 五醣體醣質化反應合成

1.4 一鍋化階段式之寡醣體醣質化反應合成簡介

一鍋化多醣體醣質反應合成 (one-pot in oligosaccharides synthesis)，即階段式 (sequential addition) 加入經修飾過保護官能基之單醣體基材於同鍋反應中，進行醣質化反應，其間不需要加以純化醣鏈結產物直到獲得最終產物才進行耗時純化步驟、亦不必擔心控制醣體活化中心碳 (anomeric activating groups) 立體選擇性，此法有如將醣體固定於聚合物基部合成法 (polymer-based synthesis) 般性質的有機化學合成。^[8]

“一鍋化醣質反應合成”的基本概念區分成三種策略。策略 A(流

程三)：醣體活性反應選擇性醣質化反應合成策略(reactivity-based glycosylation strategy)，其合成特性；運用修飾各類保護官能基團，其拉電子(electron-withdrawing)能力加以遞減單醣體基材的反應活性能力，如；Armed-disarmed protecting group modifications，^[9] 保護基於 2-OR 遞減能力順序：R = -N₃ > -O(ClAc) > -NPhth > -Bz > -Bn、^[10] 所有單醣體基材均修飾成 anomeric thio-function 此類離去基團、使用以親電子前驅物(electrophilic promoters)活化單醣體基材離去基團。

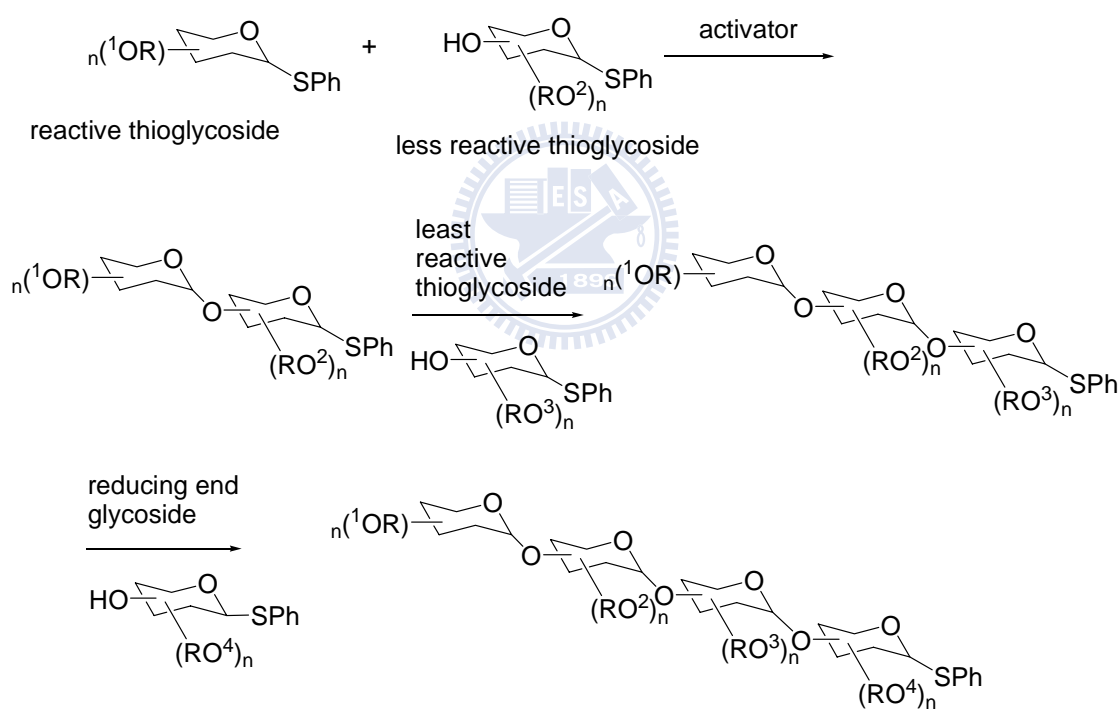

流程三、一鍋化之寡醣體醣質化反應合成策略 A

此合成法就是藉由分別修飾醣體上反應活性遞減保護基團(流程四)，^[11] 加以控制單醣體基材的反應活性能力(RRVs)高低，以

NIS-TfOH 此類親電子前驅物活化單醣體基材硫化物離去基團，於同一鍋反應下進行醣質化反應，因為醣受體本身較低反應活性 (least-RRVs)，醣受體上離去基團具選舉性的不受前驅物活化，運用階段性加入醣受體於同鍋反應中重覆進行合成步驟，在多個反應步驟之間不進行中和與純化的處理，直到獲得最終寡醣體之後再進行中和與純化步驟。

1998 年 Ley 研究團隊率先分析出，各類不同的修飾保護基之硫化物醣體相對反應活性數據，^[12]Wong 實驗團隊亦於 1999 年開發出程序控制一鍋化多醣體合成 (Programmable One-Pot Oligosaccharide Synthesis)，^[13]其一鍋化合成方法亦是先行將各類修飾單醣體基材以高壓液相層析儀(HPLC)進行分析實驗，經計算出紫外線吸收光譜後(UV)，定義出各類醣體相對反應活性值(RRVs)，當了解各類醣體活性數據後，進而設計各類醣體依反應活性大小，由高往低進行階段性加藥一鍋化合成反應，目前該研究團隊發表經分析所獲得的醣體反應活性數據將近百餘筆之多。

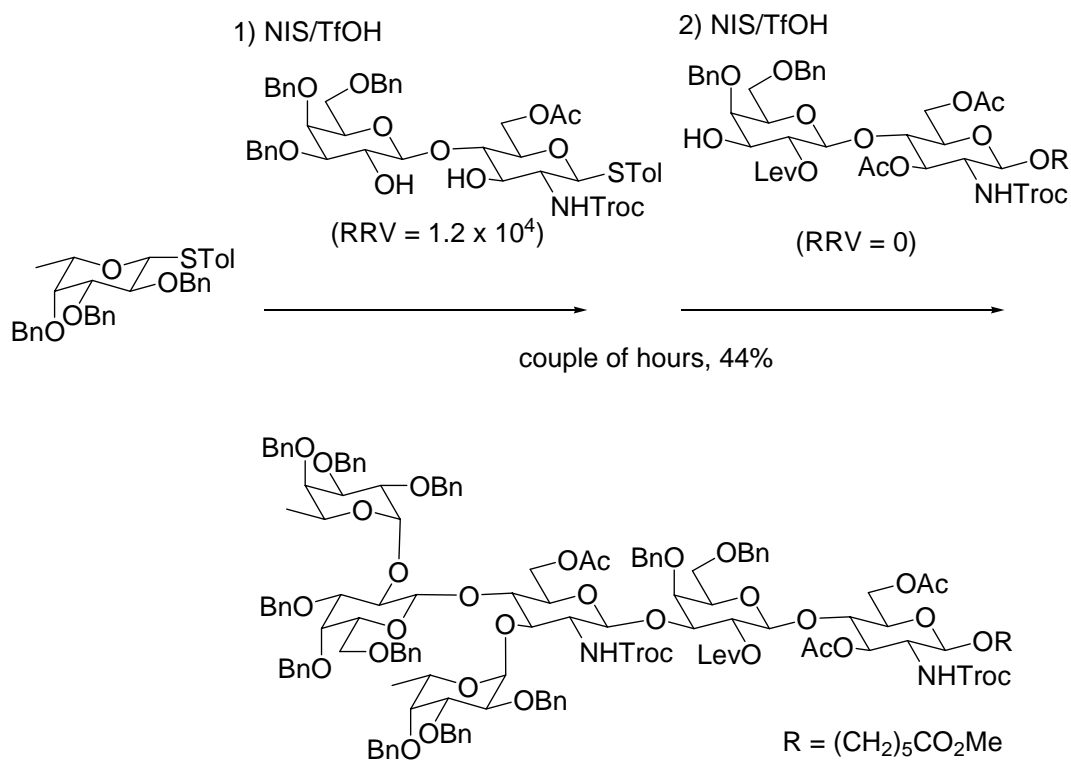

流程四、策略 A 一鍋化之反應活性選擇醣質化反應合成

此依據醣體反應活性大小進行一鍋化醣質反應，其最大缺點在於；為了將醣體 2-OH、3-OH、4-OH、6-OH 位置，修飾成不同保護基團以達到控制醣體活性大小，繁雜及耗時的修飾合成途徑，是必然的、由於進行一鍋化反應，其不單只獲得寡醣體主要產物，該反應含著少量的未反應醣受體、旁反應副產物與醣體副產物，因此在最終的純化與鑑定多醣體主要產物實驗時，必需耗時較長的操作時間。

策略 B(流程五)：幾何性醣質化反應合成策略(Orthogonal glycosylation strategy)，在上述策略 A，穩定物硫化醣體不是唯一能運用在一鍋化合成反應中的單醣體。而幾何性醣質化反應合成策略則是其衍生的另一合成法；運用不同離去基團就必須使用不同前驅物藥

劑，加以控制醣質化選擇性(promoter controlled)、與策略 A 以高反應活性醣體作一鍋化合成反應起始端相比較，策略 B 則允許以 disarmed-type 醣予體(低反應活性)鏈結 armed-type 醣受體(高反應活性)進行醣鏈結、運用醣體 6-OH 高反應活性的概念，於一鍋化條件下控制其醣質化位向鏈結選擇性(regioselectivity)。

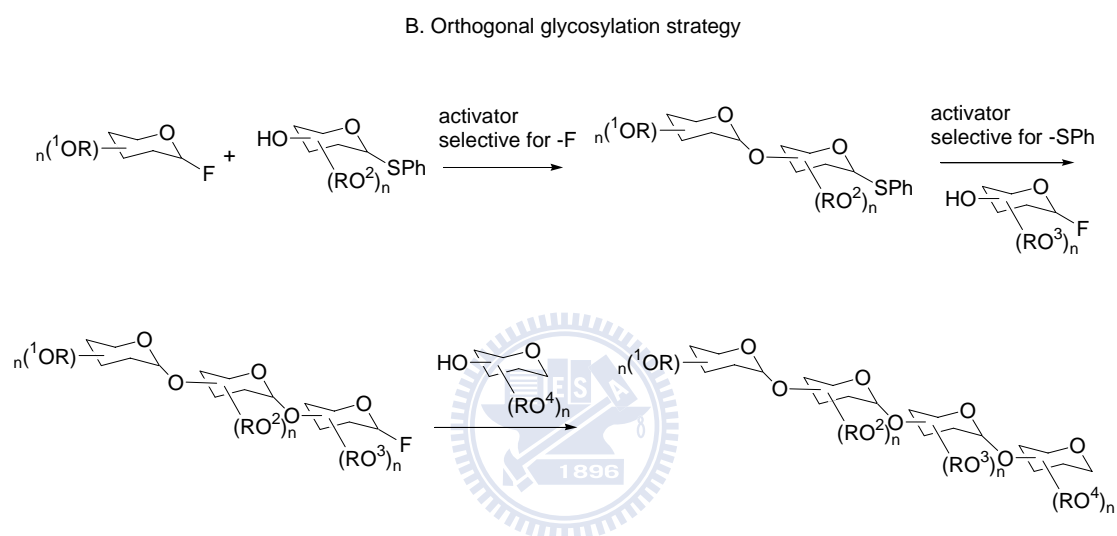

流程五、一鍋化之寡醣體醣質化反應合成策略 B

1994 年 Takahashi 等研究團隊，發表以一鍋化六步驟合成法而獲得 Phytoalexin elicitor 的七寡醣體產物(流程六)。^[14]其運用了醣體 6-OH 一級醇高反應活性進而控制位向醣質化鏈結、使用不同前驅物 MeOTf 活化醣體，進而控制避開硫化物醣體自身進行縮合反應、運用了不同離去基團醣體及相對反應活化能力高低不同的前驅物，例如: DMTST > MeOTf、HfCp₂Cl₂-AgOTf > AgOTf 控制一鍋化醣質

反應。

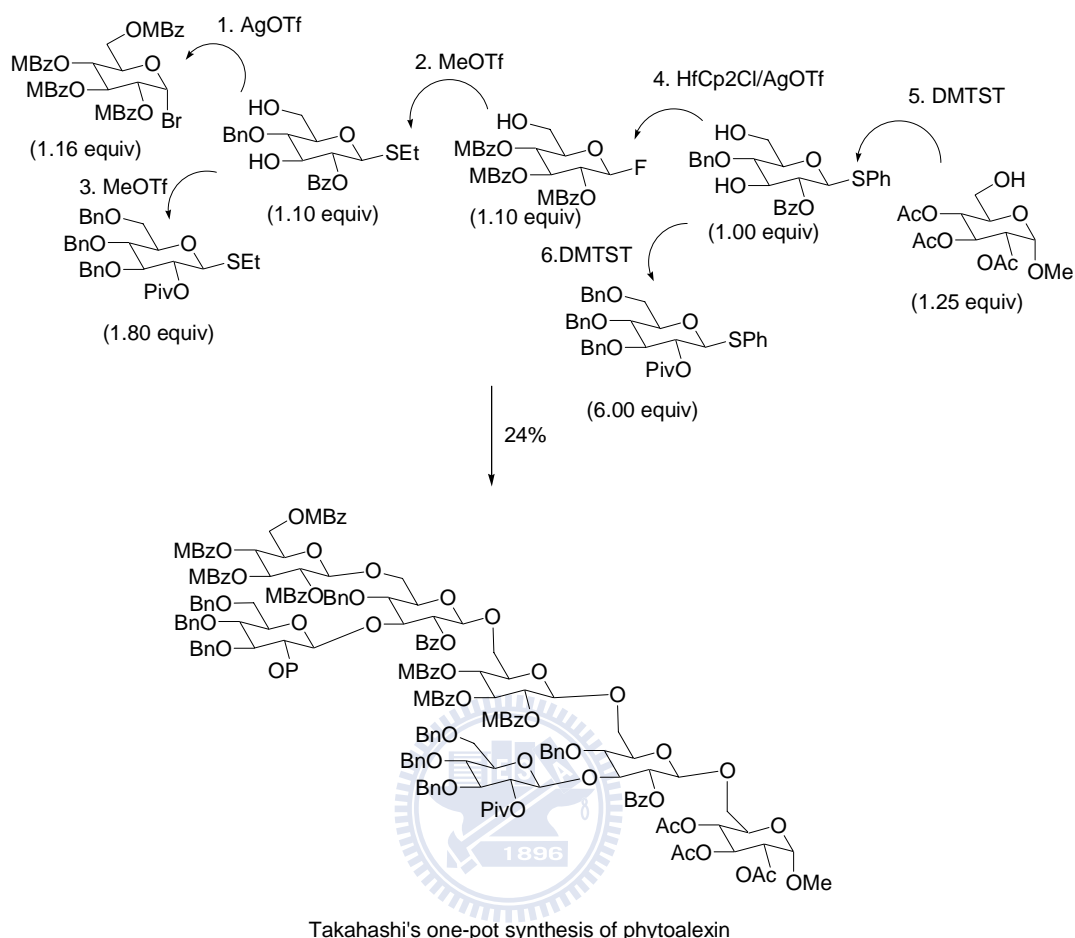

流程六、策略 B 一鍋化之幾何性糖質化反應合成

此合成策略，其最大缺點在於為了避免自身縮合反應的發生，必須選擇價格昂貴、選擇性高、高毒性試劑的前驅物進行反應，修飾成不同保護基團、及離去基團於糖體上，與策略 A 的修飾合成步驟相比較，其在合成糖中間體時重覆性不高，故合成單糖體基材耗時，純化與鑑定，必需耗時較長的操作時間。

策略 C：階段性糖質化反應合成策略(iterative glycosylation)

strategy)，此法可以回顧已發表文獻，Danishefsky's glycal methodology、^[15]Gin's dehydrative glycosylation、^[16]Yamago selenoglycosylation with bromine、^[17]Crich's thioglycosylation methodology，^[18]均是以預先活化(pre-activated)醣予體後，隨著階段性加入醣受體於一鍋中進行合成（流程七）。

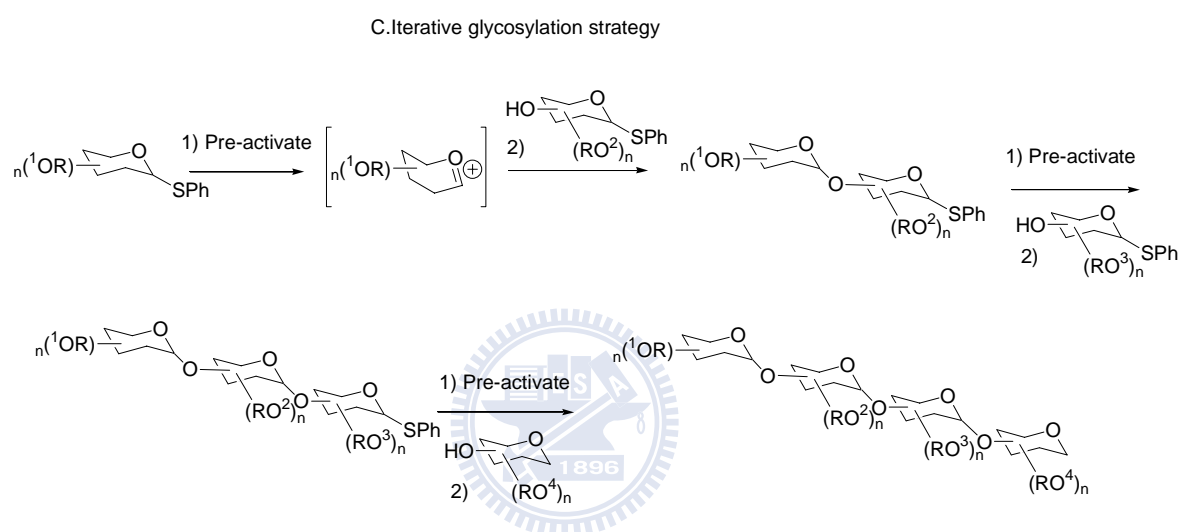

流程七、一鍋化之寡醣體醣質化反應合成策略 C

利用預先活化醣予體醣上離去基團，先產生高反應性醣體中間體後，再階段性加入醣受體於同鍋下進行合成，其醣受體具有與起始醣予體相同 anomeric 離去基團，故可重覆進行預先活化的合成步驟，於一鍋化條件下，直到產生最終醣鏈結多醣體。

2001 年 Huang et al. 已發表文獻，以化學劑量 (stoichiometric amount) 控制 AgOTf、*p*-TolSCl 於同鍋反應中形成 *p*-toluenesulfonyl

triflate，此一較高活性前驅物，進行預先活化 disarmed 醣予體後，再加入 armed 醣受體進行醣鏈結合成，重覆此步驟後而獲得最終多醣體主要產物(流程八)。^[19]

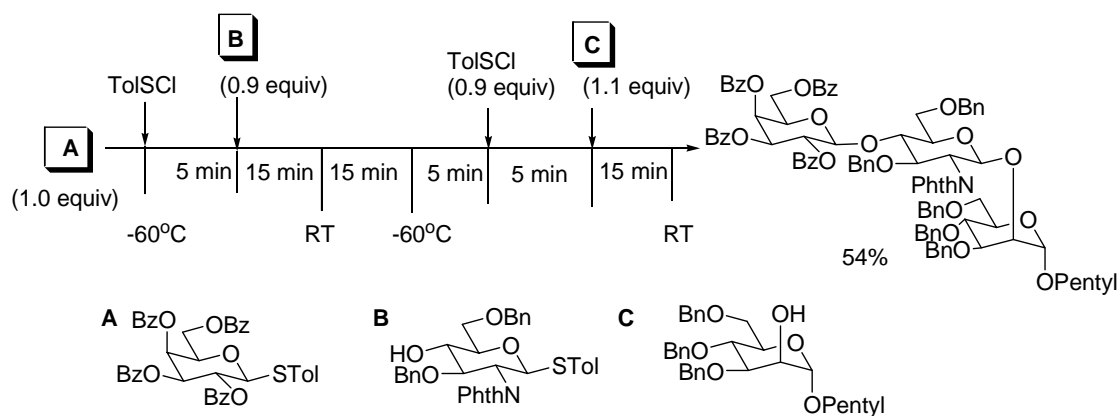

流程八、策略 C 一鍋化之階段性醣質化反應合成

階段性醣質化反應合成策略；其運用性優點為不需要考慮 armed-disarmed 單醣體基材，因反應活性的高低，所產生的合成設計難度、單醣體基材所使用的修飾基團因不必考慮醣體活性也較一致性，以達到減少去保護基團合成步驟，此法在多醣體一鍋化合成的運用性很高。

其運用性缺點：在進行階段性醣質化反應合成前必需釐清各醣質化反應步驟，尋找出最適當反應條件，再進行一鍋化合成，耗時較長、在某些醣受體發現無法進行醣質化反應、在某些條件下存在著 aglycon transfer 副反應的發生。

以上三種策略雖然所使用的方式不同，但程序都以"一鍋化"為基礎設計寡糖體醣質化合成，其總括優點為將不易在自然界中取得之寡糖體量產化、減少繁雜醣質化有機合成反應過程中所需藥劑與有毒溶劑、縮短寡糖體醣質化反應及純化所需時間、增加因過多中和純化步驟所損失的寡糖體合成產率。

1.5 β -鍵結-甘露糖之離去官能基合成應用介紹

1988年 David Crich 研究團隊研發出一 β -甘露糖醣質反應合成法，係將甘露糖體 1-OH 修飾成硫化離去官能基、氧硫化離去官能基或溴化離去官能基，以 Tf_2O 、DTBMP、BSP 或 AgOTf 、DTBMP 等活性前驅物，於超低溫條件下預先活化甘露糖予體醣上離去基團，而產生 α -glycosyl triflate 中間體後，再階段性加入醣受體於同鍋下進行雙分子親核 ($\text{S}_{\text{N}}2$) 醣質反應合成，進而獲得高 β -鍵結選擇性之甘露糖體 (流程七)。其主要 β -立體控制關鍵在於將甘露糖體上 4-OH 與 6-OH 以 benzylidene acetal 保護官能基固定住，使甘露糖體組態 (conformation) 於反應過程中傾向於 CCIP (close contact ion pairs) 中間體、於超低溫下進行實驗，如此一來更容易控制甘露糖體立體位向組態 (表一)。^[18]

表一、 Crich β -甘露糖醣質反應合成

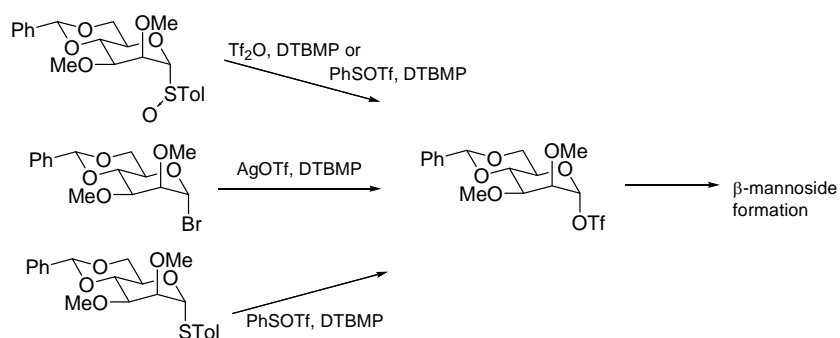

Entry	Glycosyl donor	Glycosyl acceptor	Yield(%)	α/β ratio
1			95	>1/25
2			95	>1/25
3			97	1/18
4			85	1/5.1
5			80	1/10

此 β -甘露糖醣質反應合成缺點；醣質反應活化前驅物在活化離去基後，會產生大量親電子旁反應物(electrophilic side products)、而在 1-OH 修飾成硫化離去官能基之單醣受體，在某些醣體則會產生硫化轉移旁反應物(aglycon transfer side product)。

隨後於 2000 年 Richard R. Schmidt 研究團隊亦延用 Crich 的

4,6-*O*-benzylidene acetal 的合成方法，將甘露單糖體將 1-OH 位置製備成 1-*O*-trichloroacetimidate 離去基，以催化量的路易斯酸(Lewis acid) TMSOTf 與各類糖受體於超低溫下進行逆加成(inverse addition)糖質反應合成，進而獲得β-甘露糖雙糖體主要產物(表二)。[2]

Schmidt 開發的合成反應優點具有；僅需使用微量活化前驅物即可活化 trichloroacetimidate 離去基、反應所需時間短、反應所需使用藥劑種類少，使得糖質旁反應物減低，價格亦經濟。

表二、Schmidt β-甘露糖糖質反應合成

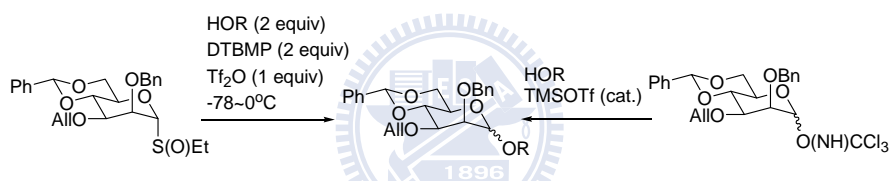

Entry	Glycosyl Donor	Glycosyl acceptor	Yield (%)	α/β ratio
1	 $R^1 = O(C=NH)CCl_3$ $R^2 = (S=O)Et$		$R^1 = 71$ $R^2 = 18$	1/3.6 1/2.7
2			$R^1 = 59$ $R^2 = 59$	β only β only
3			$R^1 = 72$	β only
4			$R^1 = 88$ $R^2 = 36$	1/2.1 1/3.6
5			$R^1 = 71$	1/8

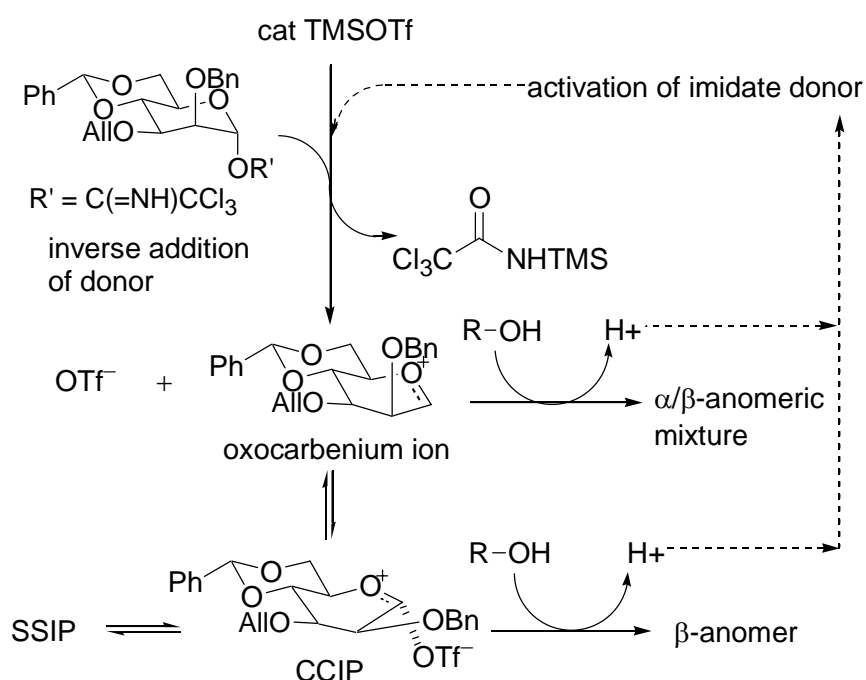

流程九、Schmidt 逆加成糖質合成反應機構

Schmidt 方法的速率逆加成糖質反應機構(流程九)首先為 1-*O*-trichloroacetimidate 苷露糖予體被催化量之路易士酸 TMSOTf (cat.)進行活化後而形成 oxocarbenium ion 苷露糖中間體，進而與 triflate anion 再形成 closed contact ion-pair(CCIP)、solvent separated ion-pair (SSIP)，所活化產生之苷露糖中間體再與糖受體進行糖質反應合成，反應同時所產生的酸性質子(acidic proton)則重新再進入活化糖予體的糖質反應循環中，以控制速率逆加成合成法活化 1-*O*-trichloroacetimidate 苷露糖予體可以防止過多的 oxocarbenium ion 苷露糖中間體形成，儘管只使用催化量路易士酸活化前驅物也能提供

足夠之 triflate anion 使得 oxocarbenium ion 甘露糖中間體再繼續形成 CCIP 中間體或 SSIP 中間體，進而壓制住 α/β anomer 混合糖體的生成，提高 β -anomer 雙糖體的獲得。

2000 年 Yukishige Ito 研究團隊開發了一 β -甘露糖鏈結合成法，分子內糖配基傳遞合成 (intramolecular aglycon delivery) 係將甘露糖體 2-OH 修飾成 PMB-此類 acetal 的官能基，再以 DDQ 進行氧化反應將糖受體鍵結在 2-O-官能基團上，再以路易斯酸 MeOTf 與 DTBMP 於低溫至加熱的方式進行分子內糖配基傳遞合成，進而獲得 β -甘露糖鏈結主要產物 (流程十)。^[20] Ito 研究團隊近年也陸續開發出不同 2-O-acetal 之官能基，亦應用於寡糖體的合成策略中。

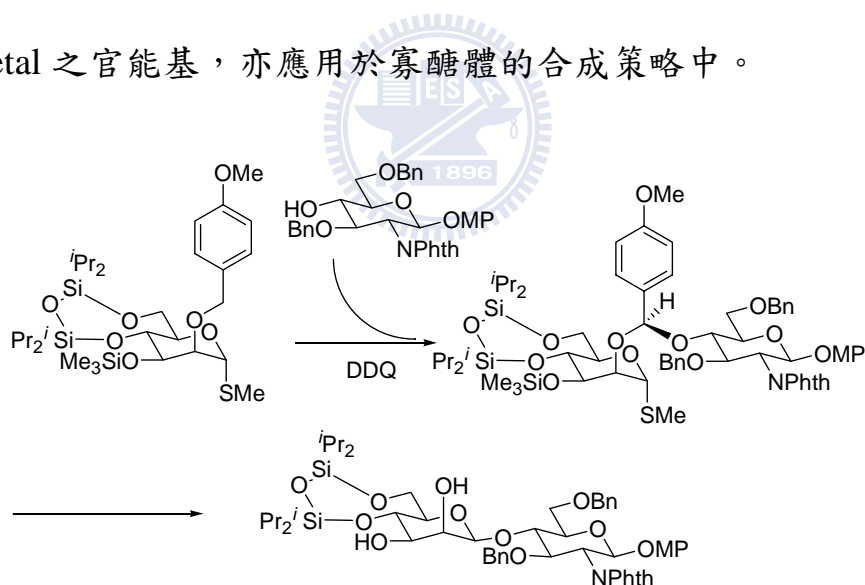

流程十、Ito β -甘露糖糖質反應合成

2008 年 Peter H. Seeberger 研究團隊亦發表了以 1-O-carboxy benzyl 離去基與 Tf_2O 、DTBMP 於低溫下進行甘露糖糖質反應，進而獲得 β -甘露糖鏈結主要產物。

此合成法亦是利用 Tf_2O 活化 1-*O*-carboxy benzyl 後，醣受體鍵結於 1-*O*-carboxy benzyl 官能基上，同時醣受體於 β -位向進行分子內醣鍵結於甘露醣上，此合成法有別於分子內醣配基傳遞合成法(表三)。^[21]

表三、 β -甘露醣醣質反應合成

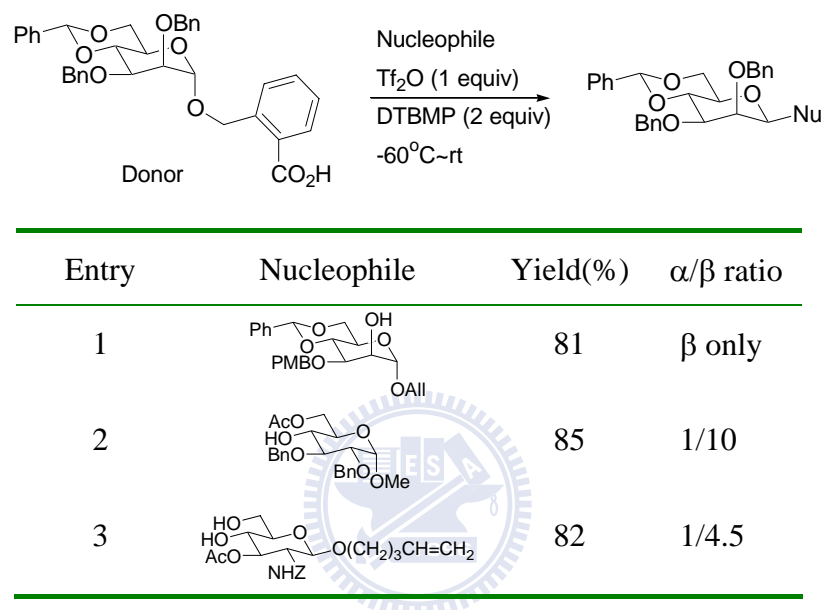

Kwan Soo Kim 研發團隊於 2006 年亦發表了一 β -甘露醣鏈結合成法(流程十一)，主要是將 1-OH 修飾成 4-pentenoate 離去基，以 PhSeOTf 為活性前驅物將甘露醣體 1-*O*-pentenoate 活化，在將醣受體階段性加入反應中使醣受體與 1-*O*-OTf 醣予體中間產物進行醣質合成反應，進而獲得 β -甘露醣鏈結主要產物(表四)。^[22]

表四、Kim β-甘露糖糖質反應合成

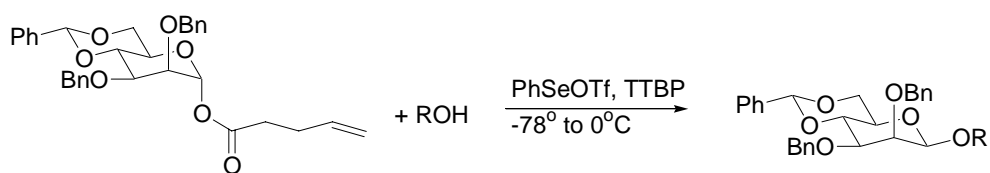

Entry	Glycosyl acceptor	Yield(%)	α/β
1		90	1/17
2		87	β only
3		85	β only
4		89	β only
5		82	β only
6		89	β only
7		87	β only
8		90	β only

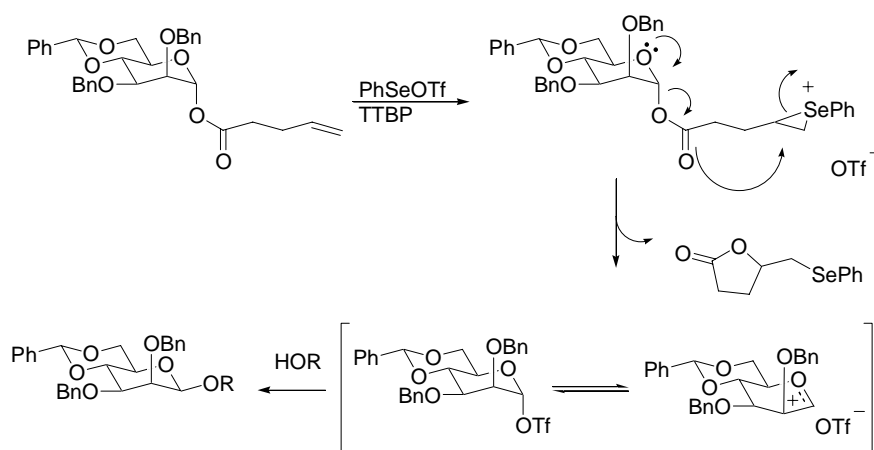

流程十一、Kim β-甘露糖糖質合成反應機構

第二章 結果與討論

2.1 一鍋化醣質反應合成 *N*-linked 核心三醣體之探討

2.1.1 Sulfoxide、thioglycoside 醣體離去基進行一鍋化三醣體醣質合成反應之運用

本實驗以寡醣蛋白脂質的五醣核心結構為標的，以"一鍋化"合成法為主要合成路徑(圖四)。又以兩個 β -鍵結乙醯葡萄糖胺、一個 β -鍵結甘露糖等鏈結三醣體進行合成研究為首要工作，其關鍵性合成控制部份為 β -鍵結甘露糖鏈結，所採用的條件為 Crich 實驗團隊所發表，^[18] 在低溫下以 TTBP^[23] 具立體障礙去質子鹼(deprotonation base) 與 Ti_2O 以先行活化醣予體後，再加入醣受體進行醣質化反應，生成具 β -鍵結甘露糖鏈結主要醣體產物。

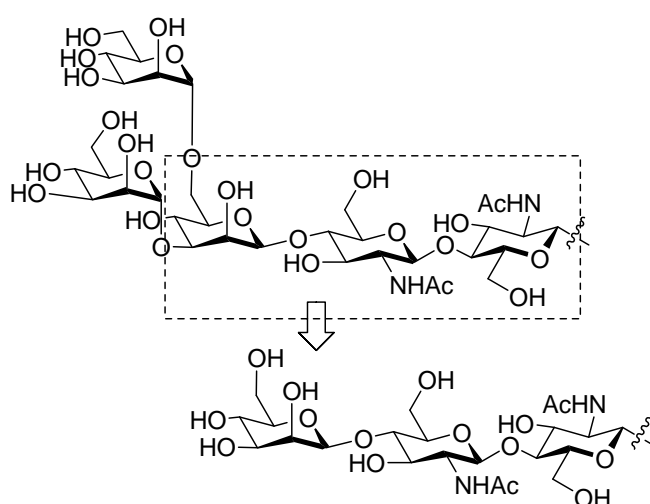

圖四、寡醣五醣體核心結構

首先修飾合成製備出，氧化硫醣予體 **1**、硫化物醣受體 **2**，此兩種單醣體基材(表五)。利用氧化硫醣予體 **1** 較高反應之化學性質，於 -78°C 下分別加入 DTBMP 或 TTBP 或 DPSO 進行活化而產生-OTf 甘露醣中間體，再加入醣受體 **2** 進行 β -鏈結反應 6 小時後，將反應以弱鹼中和、有機溶劑分液萃取，最終以管柱層析法進行純化，獲得雙醣體 **3** 與硫化甘露醣旁反應產物 **4**。由表五實驗結果中得知，當加入 TTBP 與 DPSO 藥劑時，會增加 β -甘露雙醣體 **3** 的立體選擇性與產率、減少硫化甘露醣旁反應物 **4**。

我們試著設計在進行 β -甘露醣醣質合成反應時(表六)，加入 DPSO、DBZSO、DNDPSO、TMU 等氧硫化物藥劑，藉實驗觀察在不同拉推電子性的氧硫化物藥劑是否會影響 β -立體位向選擇性，由表六實驗結果獲知，在加入 DPSO 氧硫化物藥劑時 β -立體位向選擇性是最佳的反應條件。

由(圖五、六) Sulfoxide 與 DPSO 甘露醣質化反應機構，說明了增加 β -甘露雙醣產物的主要合成途徑、如何避免獲得 aglycon transfer 旁反應物，係運用苯環硫化基的立體障礙與醣予受體的 arm-disarm 電子性來加以控制防止獲得 aglycon transfer 副反應物(圖七)。

表五、 β -鍵結甘露糖醣體醣質反應合成運用

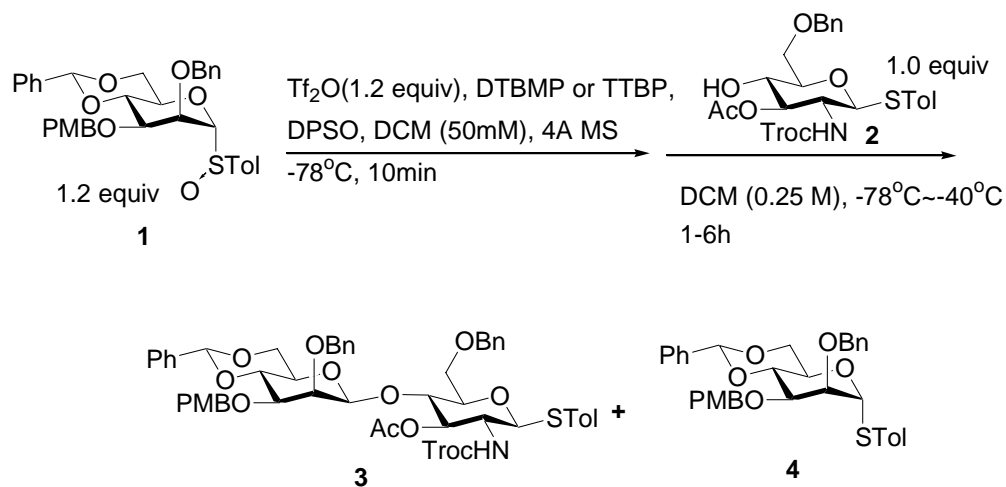

DTBMP = 2,6-di-tert-butyl-4-methylpyridine
 TTBP = 2,6-di-tert-butylpyridine
 DPSO = diphenyl sulfoxide

DTBMP (equiv)	TTBP (equiv)	DPSO(equiv)	3,4 Yield(%)	α/β^a
2.4			3 = 50, 4 = 20	1/4
--	2.4		3 = 55, 4 = 10	1/6
--	2.4	1.2	3 = 50, 4 = 10	1/10
--	2.4	3.6	3 = 50, 4 = 10	β only

a : α/β anomer ratio define with HPLC

表六、Sulfoxide molecules 之 β -鍵結甘露糖醣體醣質反應合成運用

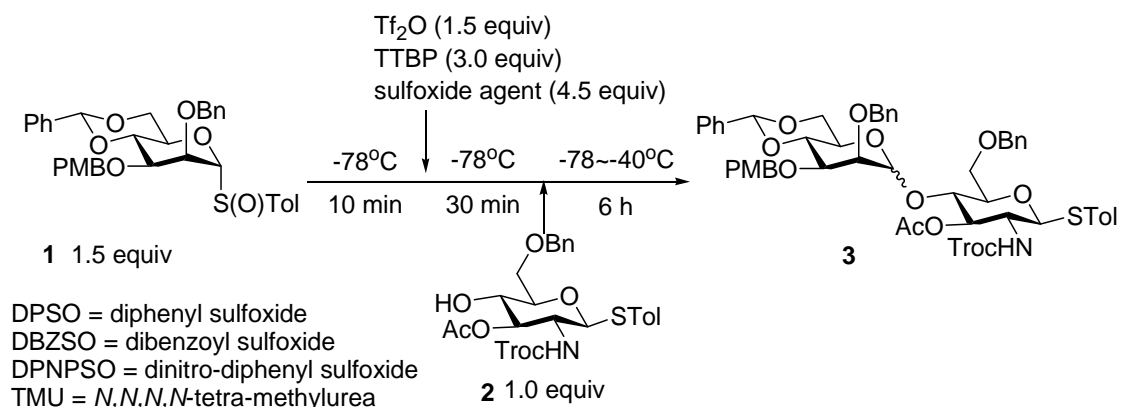

Sulfoxide agent	3 , Yield(%)	α/β^a	Sulfoxide agent	3 , Yield(%)	α/β^a
nil	55	1/6	DNDPSO	n.d.	n.d.
DPSO	55	β only	TMU	n.d.	n.d.
DBZSO	25	β only	---	---	---

a : α/β anomer ratio define with HPLC

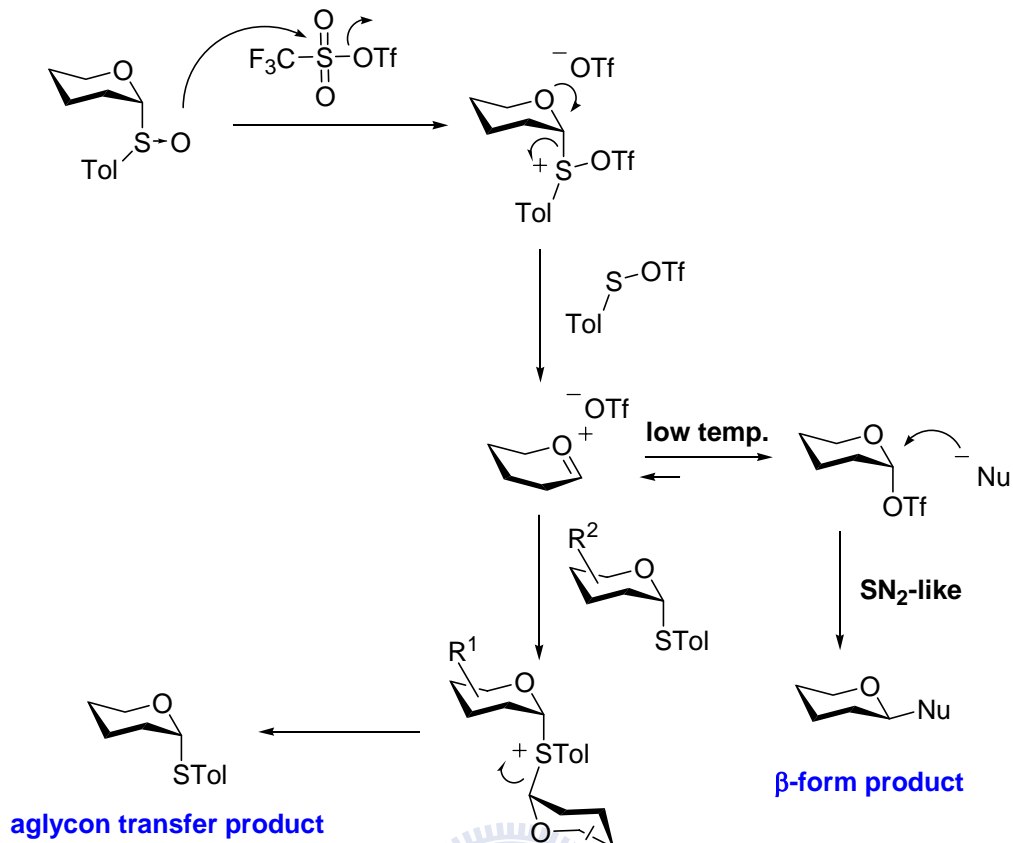

圖五、Sulfoxide β -鍵結甘露糖醣體醣質之反應機構

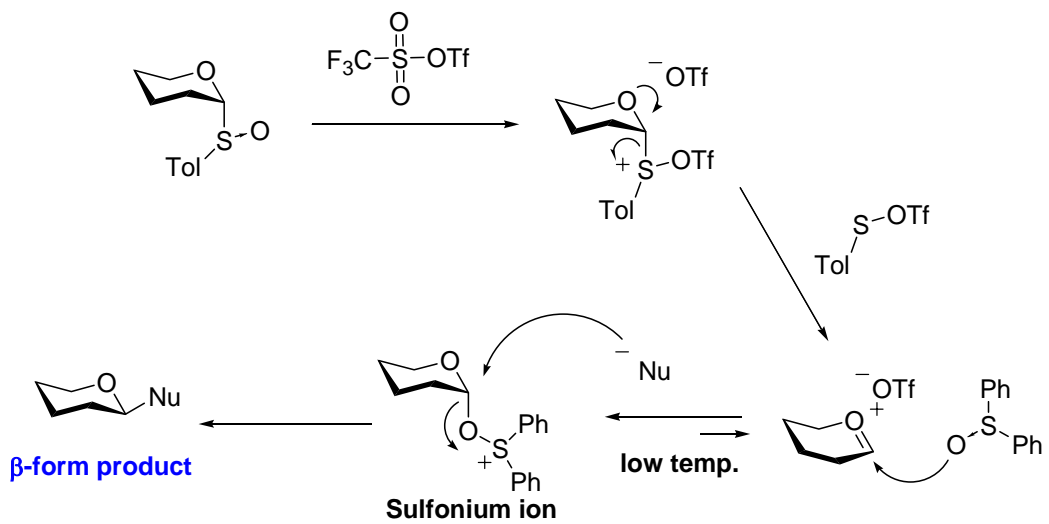

圖六、DPSO β -鍵結甘露糖醣體醣質之反應機構

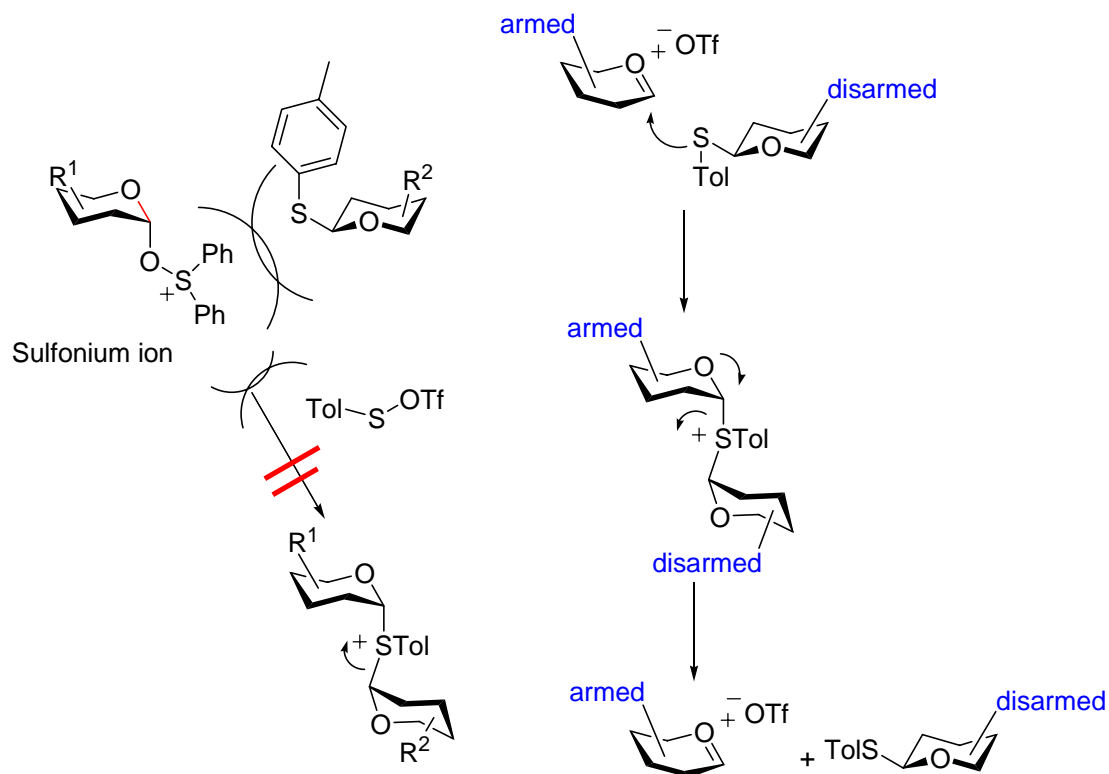

圖七、防止醣體配位基轉移之反應機構

設計將氧化硫苯甲基葡萄糖予體 **c** (armed)、硫化物乙醯基葡萄糖予體 **d** (disarmed)、TTBP 去質子鹼 **a**，以定量甲苯 **b** 為標準指示，將此四種化合物混合後 (pre-mixture)，先進行高壓液相層析儀定量分析實驗，獲得預混合高壓液相層析儀滯留時間 (HPLC retention time)、紫外線光吸收光譜定量分析數據後，於 -78°C 下再加入 Ti_2O 前驅物進行活化，反應 10 分鐘後再進行高壓液相層析儀定量分析實驗，獲得活化混合後 HPLC 數據 (流程十二)。由此兩數據對照後，在此 -78°C 溫度下使用 Ti_2O 前驅物進行活化，硫化物乙醯基葡萄糖予體 **d** 不會參與反應，此結果顯示可利用此一特性，設計氧化硫、硫

化物醣體的一鍋化合成反應。

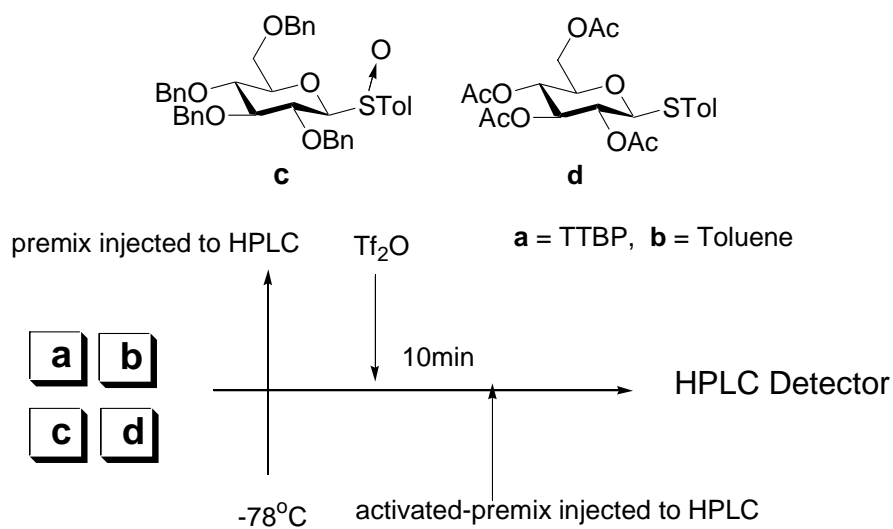

HPLC analysis (Mightysil normal phase column 4.6-250; Elution mixture: hexane/EtOAc from 90/10 to 80/20 over 30 min at 1.0 mLmin⁻¹).

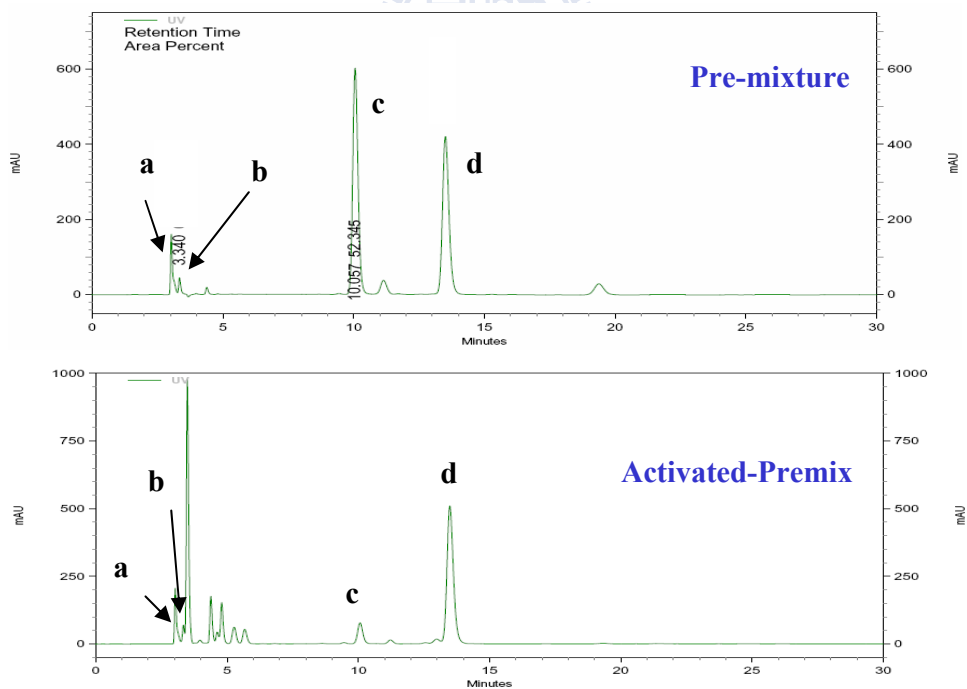

Uv Area Ratio (%) **a/c/d** = 75 / 5 / 95

流程十二、一鍋化醣體之 HPLC-UV 分析數據

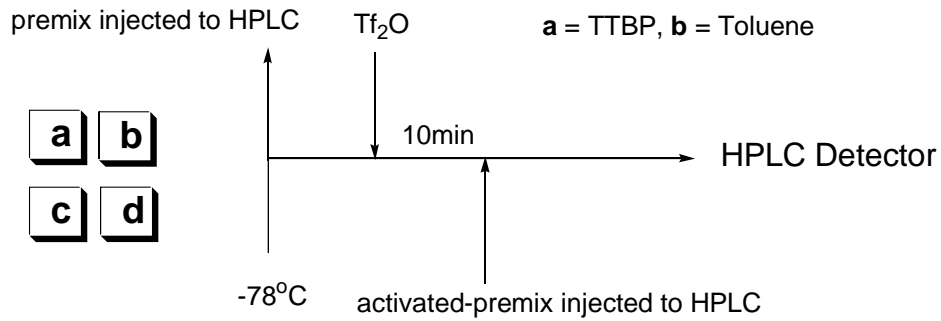
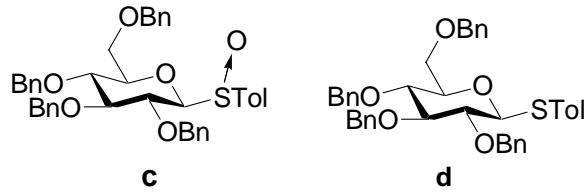

HPLC analysis (Mightysil normal phase column 4.6-250; Elution mixture: hexane/EtOAc from 90/10 to 80/20 over 30 min at 1.0 mLmin⁻¹)

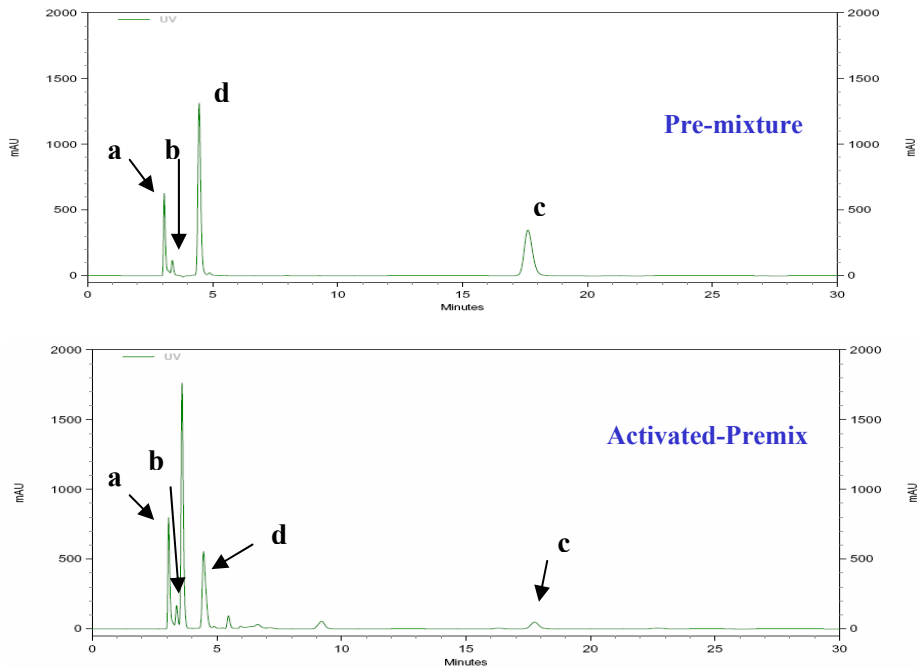

Uv Area Ratio, **a/c/d** (%) = 79 / 6 / 27

流程十三、一錫化醣體之 HPLC-UV 分析數據

同時亦設計另一實驗，首先將氧化硫苯甲基葡萄糖予體 **c** (armed)、硫化物苯甲基葡萄糖予體 **d** (armed)、TTBP 去質子鹼 **a**，以定量甲苯 **b** 為標準指示，將此四種化合物混合後，先進行高壓液相層析儀定量分析實驗，獲得預混合高壓液相層析儀保留時間、紫外線光吸收光譜定量分析數據後，於 -78°C 下再加入 Tf_2O 前驅物進行活化，反應 10 分鐘後再進行高壓液相層析儀定量分析實驗，獲得活化混合後 HPLC 數據(流程十三)。由此兩數據對照後，在此 -78°C 溫度下使用 Tf_2O 前驅物進行活化，硫化物苯甲基葡萄糖予體 **d** 會參與反應，此結果顯示無法以此種修飾硫化物苯甲基醣體，設計醣體的一鍋化合成反應。

由先前所設計的實驗得知其一鍋化醣質反應合成三醣體之可行性後，先行修飾合成製備出，氧化硫醣予體 **1**、硫化物醣體 **2**、乙醯葡萄糖氨受體 **5**，此三種醣體建構積塊(流程十四)。利用氧化硫醣予體 **1** 較高反應之化學性質，於 -78°C 分別加入 Tf_2O 、TTBP、DPSO 先行活化，再加入低反應化學性醣體 **2** 進行 β -鏈結反應 6 小時後，將溫度升高至 -60°C 同時加入乙醯葡萄糖氨受體 **5**，於 10 分鐘之後再加入 Tf_2O 、DPSO，進行 β -鏈結反應 16 小時，將反應以溶水弱鹼中和、有機溶劑分液萃取，最終以管柱層析法進行純化，獲得 20% 兩步反應產率三醣體 **6**。

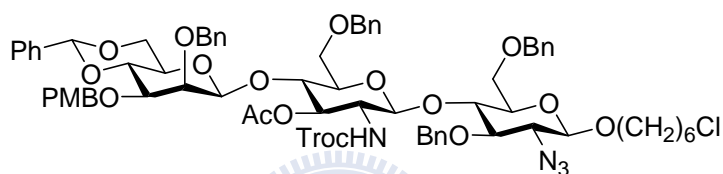
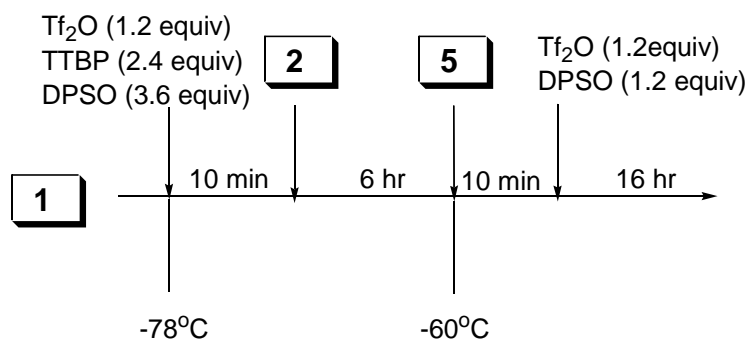
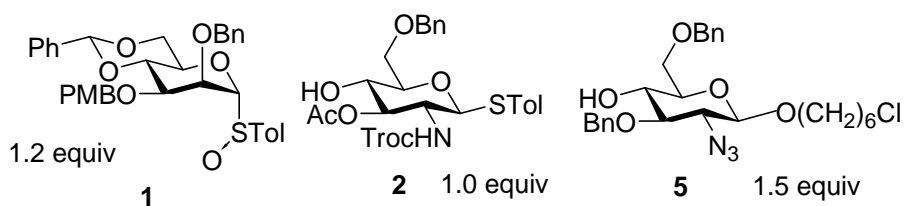

6, 20% over two steps

流程十四、一鍋化三醣體核心結構合成

此一鍋化合成法構想源自於 Wong 實驗團隊所開發的"程序控制一鍋化多醣體合成"(Programmable One-Pot Oligosaccharide Synthesis),^[13]其將各類修飾醣體基材以高壓液相層析儀 (HPLC) 進行實驗,經計算出紫外線吸收光譜後 (UV),定義出各類醣體相對反應活性 (RRVs),當了解各類醣體活性數據後,進而設計各類醣體由高往低進行階段性加藥一鍋化反應。

修飾合成製備出,氧化硫醣予體 7、硫化物醣受體 8、半乳糖胺

受體 **9**，此三種單糖基材(流程十五)。利用氧化硫糖予體 **7** 較高反應之化學性質，於 -78°C 下分別加入 Tf_2O 、TTBP、DPSO 先行活化，再加入糖體 **8** 進行 β -鏈結反應 1 小時後，將溫度升高至 -60°C 同時加入半乳糖氨受體 **9**，於 10 分鐘之後再加入 Tf_2O 、DPSO，進行 α -鏈結反應 16 小時，將反應以弱鹼中和、有機溶劑分液萃取、最終以管柱層析法進行純化，獲得 30%產率三糖體 **10**。

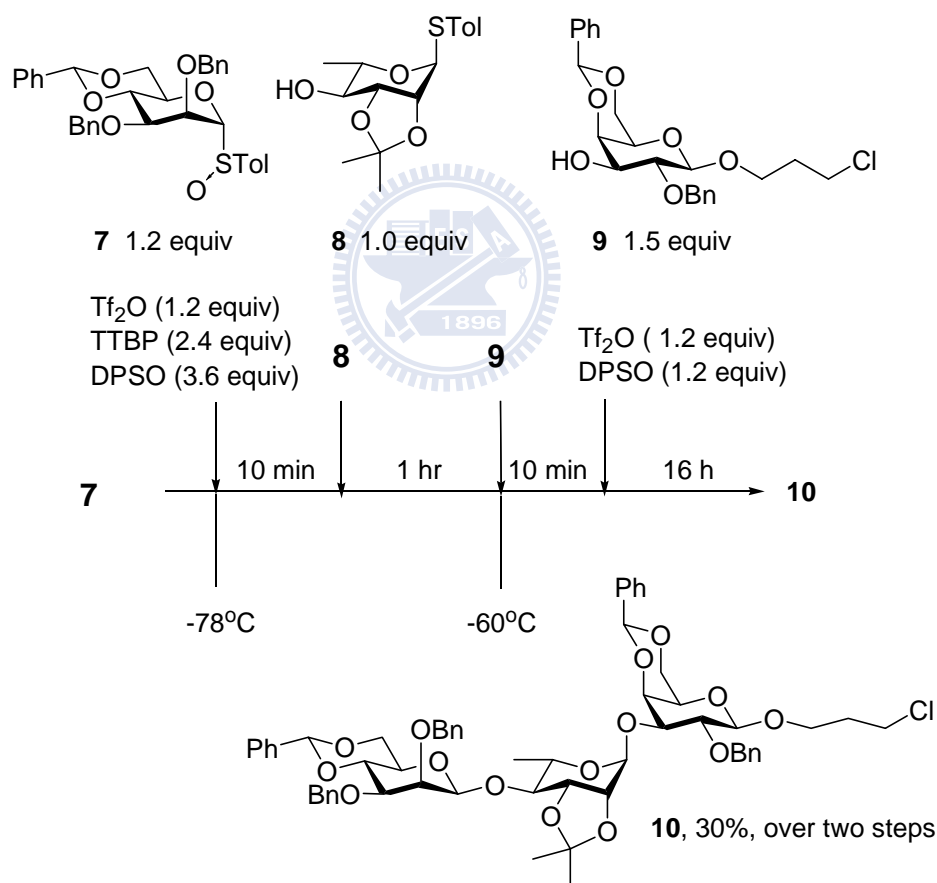

流程十五、一鍋化三糖體結構合成

由於進行一鍋化糖質反應純化後卻僅獲得 20%三糖體 **6**、30%三

醣體 **10**，實驗中我們發現在使用 Crich β -甘露醣醣質反應合成法中，所投入大量 TTBP、 Tf_2O 、DPSO 藥劑而產生大量親電子性副反應物 (electrophile side products) 為影響產率原因之一、而產生醣體配位基轉移副反應物 (aglycon transfers side products) 為影響產率原因之二。

2.1.2 Trichloroacetimidate、2,6-dimethylthiophenyl 醣體離去基進行一鍋化三醣體醣質合成反應之運用

2006 年 J. C. Gildersleeve 研究團隊發表一防止醣配位基轉移旁反應 (aglycon transfer side products) 的合成方法 (流程十六)，^[24]

係將具立體障礙之苯環硫化物 (2,6-dimethylthiophenyl) 修飾於醣受

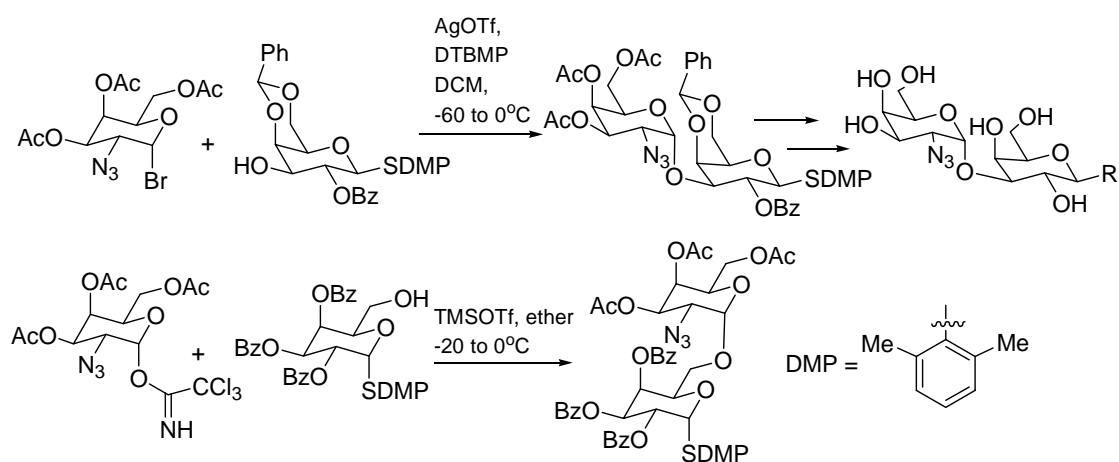

流程十六、DMTP 硫化物離去基防止醣體配位基轉移

體 1-OH 位置上，利用離去基的立體障礙來避免產生醣配位基轉移旁

反應，而我們也使用了此一合成法，修飾了幾種將使用於一鍋化醣質反應之醣受體上。

運用 Schmidt 的合成法製備出 1-*O*-trichloroacetimidate 甘露醣予體 **11** 與運用 2,6-dimethylthiophenyl 離去基製備雙甲基硫化葡萄糖胺醣受體 **12**(表七)，分別以不同劑量之路易士酸 TMSOTf 於 -70°C 下進行β-甘露醣醣質反應合成而獲得雙醣體 **13**，由表七實驗結果得知當隨著增加 TMSOTf 酸量時，亦增加了甘露醣β-立體位向的選擇性，同時也有效防止醣體配位基轉移旁反應物的產生。

表七、 路易士酸量控制β-甘露醣鍵結主要產物之運用

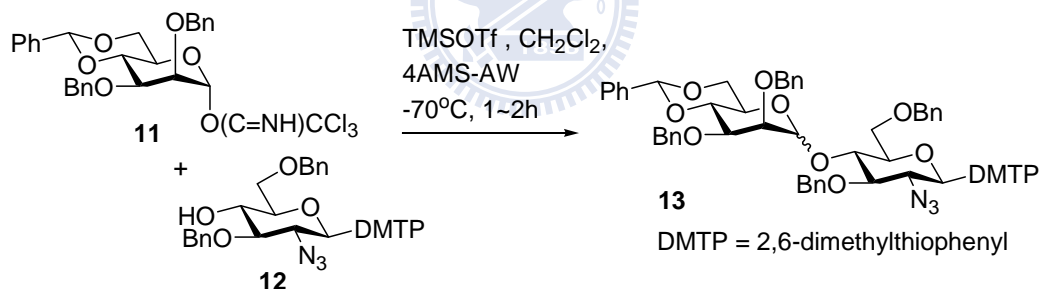

TMSOTf (equiv)	DCM (Mm)	Recovered acceptor (%)	13 , Yield (%)	α/β^a
0.1	80	15	65	1/1.2
1.0	10	10	35	1/6.7
1.0	80	5	75	1/5.5
2.5	80	5	70	1/5

a : α/β anomer ratio define with HPLC

我們使用此合成方法加以設計進而運用在一鍋化三醣體醣質反

應上(流程十七)，首先將甘露糖予體 **11** 與葡萄糖胺糖受體 **12**，於 -70°C 下降溫 10 分鐘，再加入與糖予體 **11** 等 mole 數量之路易士酸 TMSOTf(1.5 equiv)，於 -70°C 下反應兩小時，同鍋反應中再加入葡萄糖胺糖受體 **5**，於低溫下使用本實驗室所開發的低濃度糖質化反應進行 β -糖體鍵結而獲得兩步反應產率 45% 三糖體 **14**。

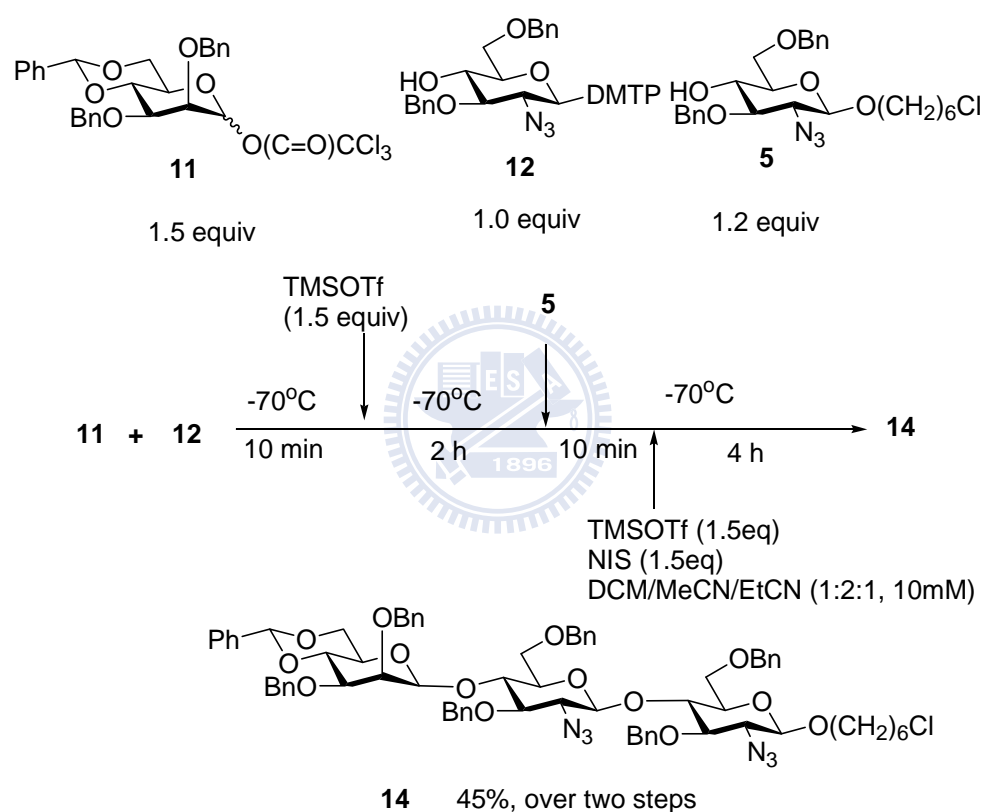

流程十七、 TMSOTf 酸量控制之一鍋化三糖體糖質反應合成運用

於三糖體 **10** 合成反應上亦使用當量 TMSOTf 控制 β -甘露糖鍵結立體選擇性，一鍋化合成方式下分別將糖體基材 **11**、**15** 於 -70°C 加入 TMSOTf (1.5 equiv) 進行 β -鍵結反應 1 小時後，於 -40°C 下加入糖

體基材 **9** 再加入 TMSOTf (1.5 equiv)、NIS(1.2 equiv)，待溫度升高制-20°C 行 α -鍵結反應 4 小時，將反應以弱鹼中和、有機溶劑分液萃取、最終以管柱層析法進行純化，獲得兩步反應 35% 產率三糖體 **10** (流程十八)。

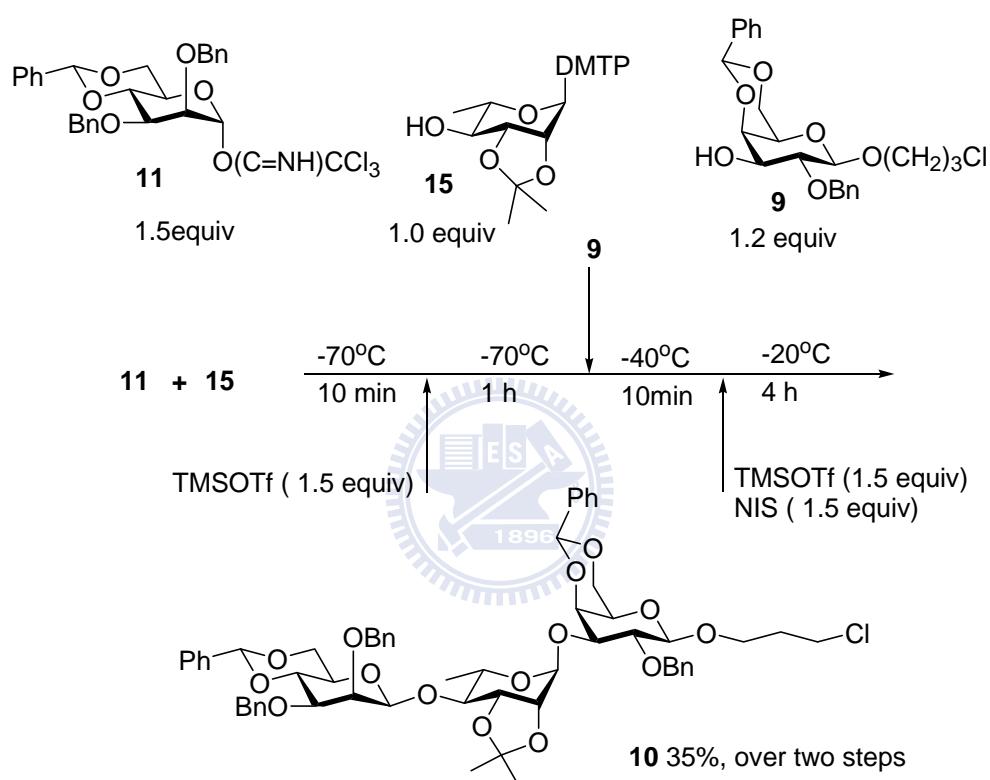

流程十八、 TMSOTf 酸量控制之一鍋化三糖體醣質反應合成運用

2.1.3 運用速率逆加成程序法控制 β -甘露糖糖質鍵結之寡

糖體一鍋化合成與應用

2000 年 Richard R. Schmidt 研究團隊已發表文獻中，^{[2]j}使用了逆加成法進行 β -甘露糖糖質反應鍵結，而獲得高 β -立體選擇性的甘露糖雙糖體，在我們重複該合成條件實驗中發現改變加入糖予體速率，甘露糖雙糖體之 β -立體選擇性亦會隨著糖予體加入速率不同而有所改變（表八）。

表八、速率逆加成程序法控制 β -甘露糖雙糖體糖質鍵結

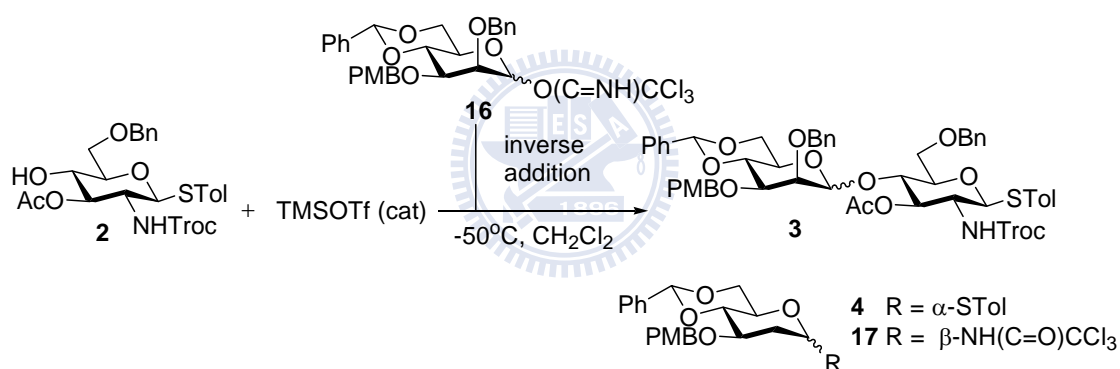

Addition rate of 0.25 M of 16 mLmin ⁻¹	3 , Yield (%), α/β^a	4 , Yield (%)	17 , Yield (%)
NA ^b	48, 1/2	20	0
0.2 ^c	65, 1/9.5	5	10
0.07	47, 1/4.5	20	10
0.035	40, 1/4.5	20	10

a: α/β -anomeric ratios were determined by HPLC analysis

b: Conventional addition procedure was adopted.

c: Glycosylation experiment was repeated twice and same α/β anomeric ratios were obtained.

我們亦使用二級醇單糖受體基材 **18**、一級醇單糖受體基材 **19** 與甘露糖單糖予體基材 **11** 以控制速率逆加成進行β-甘露糖糖質反應鍵結(表九)，由表五實驗結果得知二級醇單糖受體基材 **18** 在以控制速率逆加成法進行實驗後有明顯增加β-甘露糖雙糖體 **20**，而在一級醇單

表九、速率逆加成程序法控制β-甘露糖雙糖體糖質鍵結

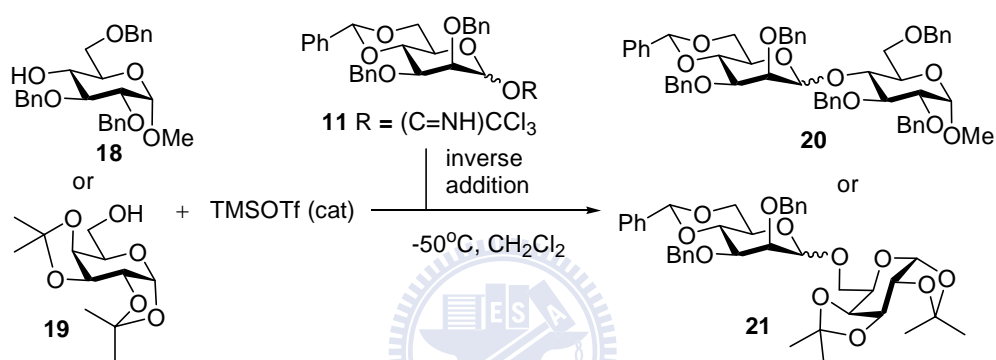

Addition rate of 0.25 M of 11	Glycosyl acceptor	Disaccharide yield (%), α/β^a
NA ^b	18	20 = 88, 1/2
0.2	18	20 = 85, 1/10
0.07	18	20 = 85, 1/8
NA ^b	18	20 = 88, 1/2
0.4	19	19 = 92, 1/2.3
0.14	19	19 = 87, 1/2.3
NA ^b	19	19 = 50, 2/1

a: α/β -anomeric ratios were determined by HPLC analysis

b: Conventional addition procedure was adopted.

c: $\text{BF}_3 \cdot \text{Et}_2\text{O}$ (1 mol equiv) was used for activating imidate donor **10**.

醣受體基材 **19** 以控制速率逆加成法進行實驗後無明顯增加 β -甘露雙醣體 **21**，而在使用 $\text{BF}_3 \cdot \text{Et}_2\text{O}$ 作活性前驅物時，實驗結果增加 α -甘露雙醣體 **21**。

以速率逆加成程序合成法加以控制 β -醣體鍵結進而運用在一鍋化三醣體醣質反應上(流程十九)，首先將葡萄糖胺受體 **2** 與催化量之路易斯酸 TMSOTf (cat)於 -50°C 下降溫 10 分鐘，再以 0.2 mLmin^{-1} 速率控制加入甘露醣予體 **16**，於 -50°C 下反應兩小時後，以弱鹼中和、

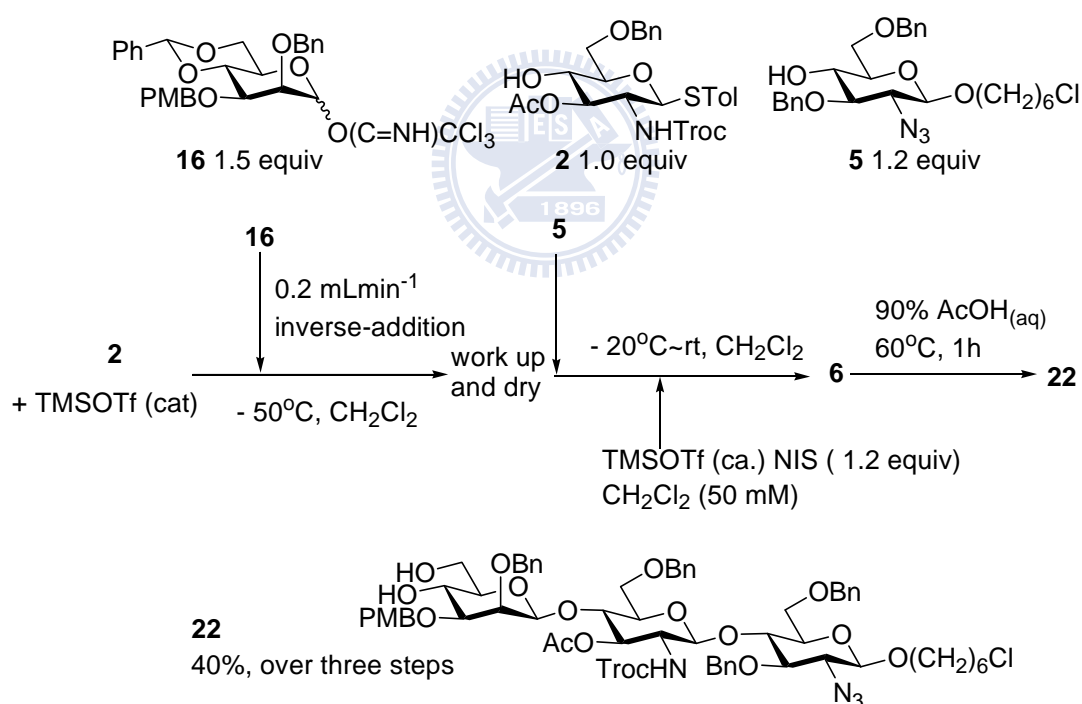

流程十九、控制速率逆加成程序法之一鍋化三醣體醣質反應合成運用

過濾分子篩(molecular sieve)、分液漏斗萃取除水、真空乾燥後，同

鍋反應中再加入葡萄糖胺糖受體 **5**，於 -20°C 下加入 TMSOTf (cat.)、NIS (1.2 equiv)進行 β -糖體鍵結而獲得三糖體 **13**，再以弱鹼中和、過濾分子篩(molecular sieve)、分液漏斗粹取除水、真空乾燥後，再加入少量 90% 冰醋酸水溶液加熱一小時後，減壓蒸餾除去冰醋酸水溶液再以中壓液相層析管柱(MPLC)進行純化分離，獲得三步反應 40% 產率三糖體 **22**。

另外亦是以速率逆加成程序合成法加以控制合成 β -甘露糖體鍵結雙糖體 **23** (流程二十)，首先將 2,6 雙甲基硫化(DMTP)鼠李糖 (L-rhamanopyranoside)受體 **15** 與催化量之路易士酸 TMSOTf (cat.)於 -50°C 下降溫 10 分鐘，再以 0.4 mLmin^{-1} 速率控制加入甘露糖予體 **11**，於 -50°C 下反應 1 小時後，以弱鹼中和、過濾分子篩(molecular sieve)、分液漏斗萃取除水、真空乾燥後，以中壓液相層析管柱(MPLC)進行純化分離，獲得 90% 產率雙糖體 **23**。

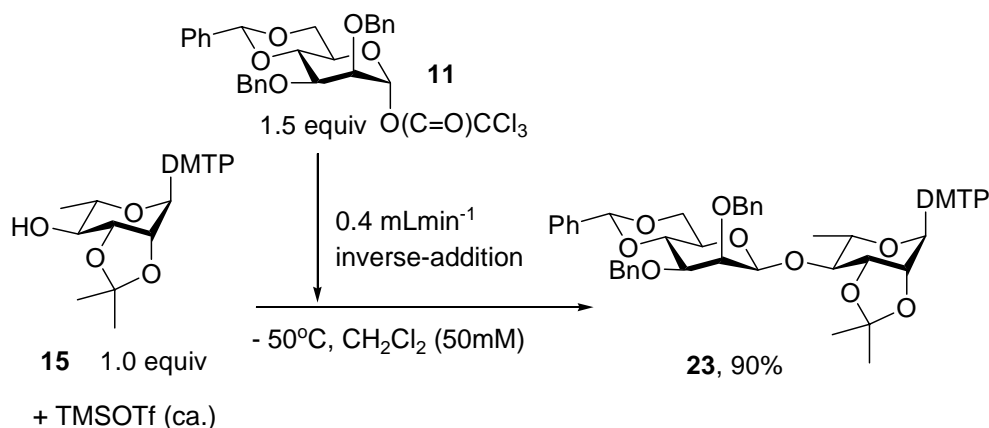

流程二十、控制速率逆加成程序法之雙糖體糖質反應合成

同時亦以速率逆加成程序合成法運用在一鍋化三醣體 **10** 合成反應上(流程二十一)，首先將 2,6 雙甲基硫化鼠李糖受體 **15** 與催化量之路易斯酸 TMSOTf(ca.) 於 -50°C 下降溫 10 分鐘，再以 0.4 mLmin^{-1}

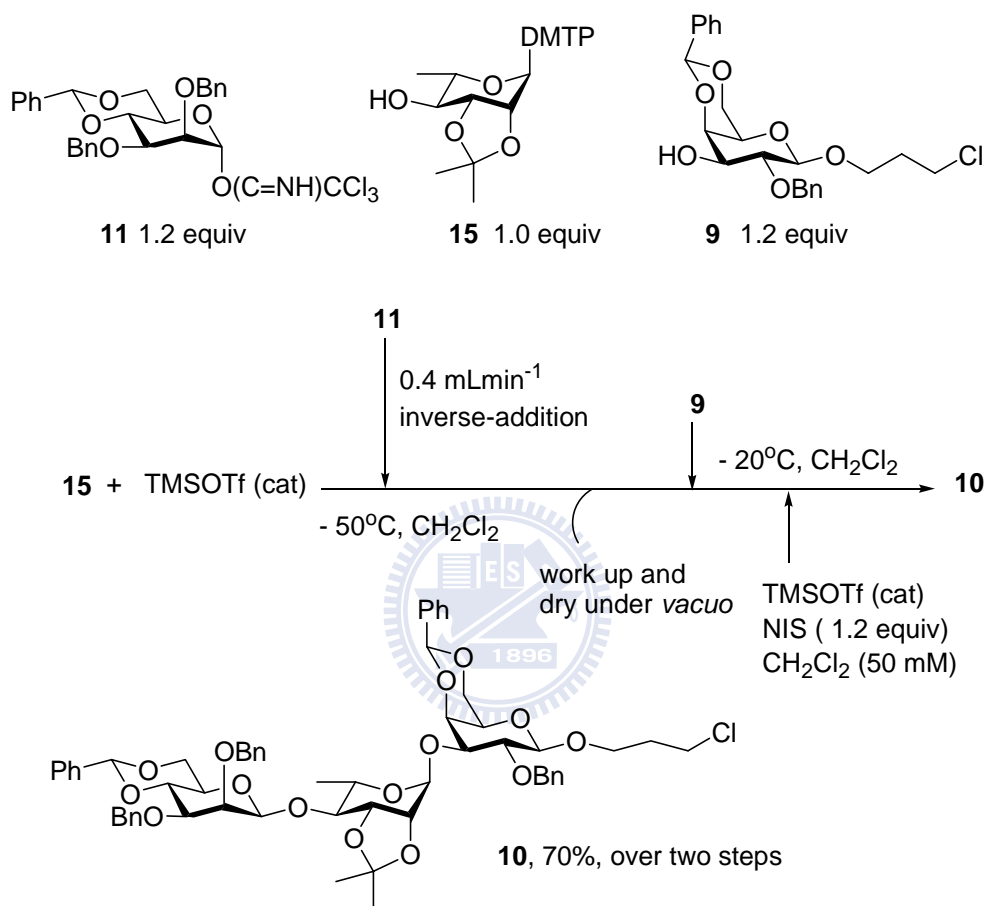

流程二十一、一鍋化三醣體醣質反應合成應用

速率控制加入甘露糖予體 **11**，於 -50°C 下反應一小時後，以弱鹼中和、過濾分子篩(molecular sieve)、分液漏斗萃取除水、真空乾燥後，同鍋反應中再加入葡萄糖胺糖受體 **9**，於 -20°C 下加入 TMSOTf (cat.)、NIS (1.2 equiv) 進行 α -醣體鍵結而獲得三醣體 **10**，再以弱鹼

中和、過濾分子篩 (molecular sieve)、分液漏斗萃取除水、真空乾燥後，再以中壓液相層析管柱 (MPLC) 進行純化分離，獲得兩步反應 70% 產率三醣體 **10**。

由速率逆加成醣質反應實驗結果解釋β-甘露醣體合成時之反應機構(流程二十二)，首先 1-O-trichloroacetimidate 甘露醣予體被催化量

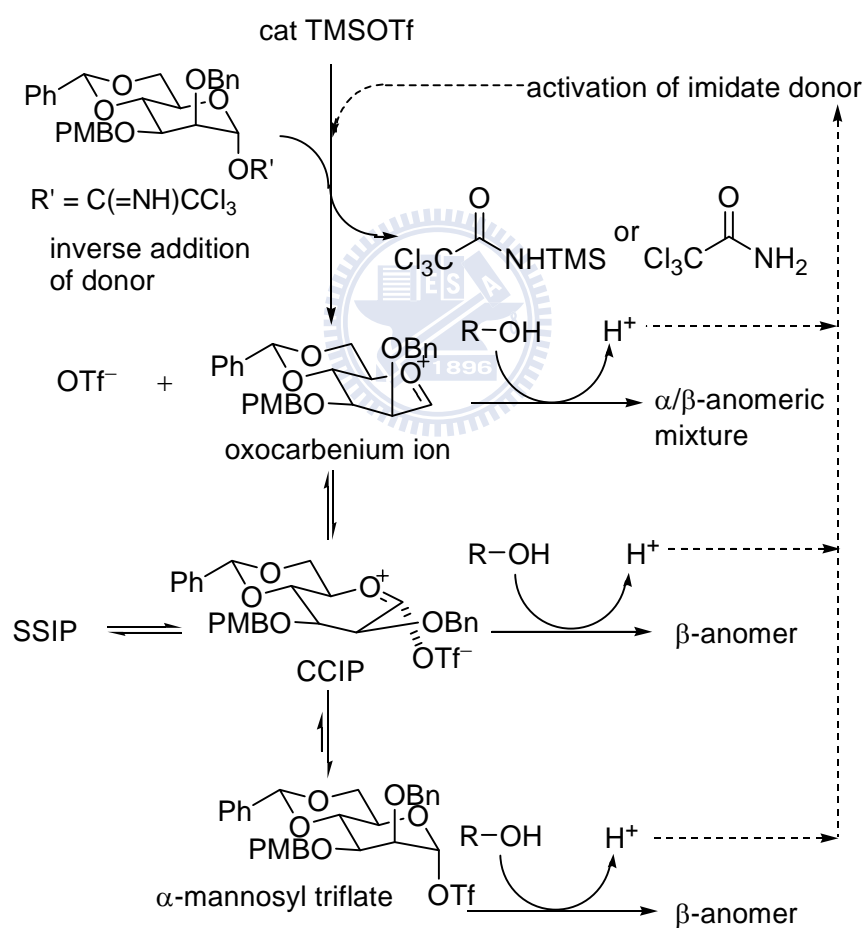

流程二十二、速率逆加成-甘露雙醣體合成反應機構

之路易士酸 TMSOTf(cat) 進行活化後而行成 oxocarbenium ion 甘露醣

中間體，進而與 triflate anion 再形成 closed contact ion-pair(CCIP)、solvent separated ion-pair(SSIP)與 α -mannosyl triflate，所活化產生之甘露糖中間體再與糖受體進行糖質反應合成，反應同時所產生的酸性質子(acidic proton)則重新再進入活化糖予體的糖質反應循環中，以控制速率逆加成合成法活化 1-*O*-trichloroacetimidate 甘露糖予體可以防止過多的 oxocarbenium ion 甘露糖中間體形成，儘管只使用催化量路易斯酸活化前驅物也能提供足夠之 triflate anion 使得 oxocarbenium ion 甘露糖中間體再繼續形成 CCIP 中間體或 SSIP 中間體，進而壓制住 α/β anomer 混合糖體的生成，提高 β -anomer 雙糖體的獲得，在實驗結果中我們也發現反應活性較低的二級醇糖受體的 β -糖體立體選擇性比反應活性較高的一級醇糖受體更來的顯著，高反應活性一級醇糖受體容易與 triflate anion 產生競爭於 oxocarbenium ion 甘露糖中間體上，結果生成 α -雙糖體主要產物。

結論

1. 首先我們重複實驗 Crich 所研發的氧硫化離去基甘露糖予體合成法，在實驗中我們也針對一系列氧硫化物藥劑對 β -甘露糖體鍵結進行了糖質反應合成實驗，由實驗結果發現 DPSO 氧硫化藥劑的參與對 β -甘露糖體鍵結比率有顯著的增加，進而將其設計運用在一鍋化三糖體糖質反應上，但由於所投入大量 TTBP、Tf₂O、DPSO 等藥劑而產生大量親電子性旁反應物(electrophilic side products)與硫化離去基糖受體會產生糖體配位基轉移旁反應物(aglycon transfers side products)，使得一鍋化三糖體糖質反應最終獲得的產率過低。
2. 在釐清了產生糖體配位基轉移旁反應物的反應機構之後，製備出以立體障礙防止糖體配位基轉移旁反應物生成的 2,6 雙甲基硫化離去基 (2,6-dimethylthiophenyl) 糖受體再與 1-O-trichloroacetimidate 糖予體以等莫耳量路易士酸 TMSOTf 提高 β -甘露糖體鍵結選擇性，實驗結果發現成功防止了糖體配位基轉移旁反應物的生成，但在一鍋化三糖體糖質反應中卻因使用過量的酸使得三糖體產率不高，同時也會破壞甘露糖體 3-O-PMB 保護基的修飾，無法進行甘露糖體位向選擇性(regioselectivity)的設計。

計。

3. 在重複 Richard R. Schmidt 所研發的逆加成法進行 β -甘露糖質反應合成時，實驗中發現改變加入糖予體速率，甘露糖雙糖體之 β -立體選擇性亦會隨著糖予體加入速率不同而有所改變而獲得高 β -立體選擇性的甘露糖雙糖體之後，再進行一系列不同速率逆加成程序實驗，將最優化速率逆加成條件運用於一鍋化三糖體糖質反應合成上，在實驗中使用催化量路易士酸並使用控制速率逆加成糖質反應合成法而獲得高產率與減少旁反應物的產生，我們相信控制速率逆加成糖質反應合成法在寡糖體合成領域中應該有更廣大的應用性與便利性。



第三章 實驗部份

3.1 General experimental

Chemicals used in this investigation were purchased as ACS reagent grade from commercial vendors and used without further purification. CH_2Cl_2 (from Mallinckrodt), MeOH and CH_3CN (from J.T. Baker) were distilled over calcium hydride. Anhydrous DMF (100 mL from J.T. Baker) was treated with activated molecular sieves before use. Addition rate of mannosyl imidate donor was controlled by syringe pump from SAGE instruments model 341B. Progress of reaction was monitored with thin-layer chromatography (TLC) on silica gel F-254 plate and visualized with UV (254 nm) illumination and/or by staining with *p*-anisaldehyde staining reagent. Optical rotations of compounds were measured by JASCO DIP-1000 polarimeter at 27°C. Flash column chromatography was performed on either 70-230 mesh size or 230-400 silica gel obtained from E. Merck. Elution over 230-400 silica gel was done with medium pressure liquid chromatography (MPLC) driven by BÜCHI 688 model pump. ^1H and ^{13}C NMR spectra were recorded with respective 300 MHz and 75 MHz spectrometers by either Brüker or Varian Unity-300 NMR spectroscopy. Chemical shift (δ ppm) was calibrated against the residual proton signal and the ^{13}C signal of deuterated chloroform (CDCl_3). Coupling constant(s) in hertz (Hz) were calculated from differences in chemical shifts derived from ^1H NMR spectra. α/β -Anomer ratios of glycosylation isomers were determined by HPLC analysis, which was

performed on Mightysil Si 60 250-4.6 normal phase column with EtOAc/CH₂Cl₂/hexane gradient elution. HPLC elution was achieved by Hitachi L-2130 gradient pump at 0.8 mL/min and eluted compounds were detected with Hitachi L-2300 UV detector.

3.2 Experimental

3.2.1 General procedure

3.2.1.1 A. β -Mannosylation with additive of DPSO using sulfoxide donor

To the solution of sulfoxide donor **1** (102 mg, 0.20 mmol), TTBP (102 mg, 0.41 mmol), DPSO (124 mg, 0.61 mmol) and Tf₂O (33 μ L, 0.2 mmol) were dissolved in CH₂Cl₂ (4 mL) under N₂ at -78°C stirred 10 min, and then was added slowly the solution of glycoside acceptor **2** (100 mg, 0.17 mmol) in CH₂Cl₂ (1mL), at -78 to -60°C under N₂ stirred 1 to 6 h. Upon completion of β -mannosylation as judged by TLC, the reaction was quenched with addition of few drops of satd. NaHCO₃, The resulting solution was then filtered through celite, and filtrate was washed with water (20 mL \times 2), brine (20 mL \times 1), dried (MgSO₄), filtered, and then concentrated for column chromatography purification (Elution: EtOAc/hexane = 1:4) furnishing tolyl 3-*O*-acetyl-6-*O*-benzyl-2-deoxy-4-*O*-(2-*O*-benzyl-4,6-*O*-benzylidene-3-*O*-*p*-methoxybenzyl-D-man nopyranosyl)-2-(trichloroethyloxycarbonyl)-1-thio- β -D-glucopyranoside **3** (90 mg, 50%), tolyl 2-*O*-benzyl-4,6-*O*-benzylidene-3-*O*-*p*-

methoxybenzyl-1-thio- α -D-mannopyranoside **4** (10 mg, 10%).

3.2.1.2 B. One-pot glycosylation of trisaccharide with addition of DPSO using sulfoxide donor

To the solution of sulfoxide donor **1** (102 mg, 0.20 mmol) or **7** (220 mg, 0.38 mmol), TTBP (102 mg, 0.41 mmol for **1**; 190 mg, 0.77 mmol for **7**), DPSO (124 mg, 0.61 mmol for **1**; 233 mg, 1.15 mmol for **7**) and Tf₂O (33 μ L, 0.2 mmol for **1**; 63 μ L, 0.38 mmol for **7**) were dissolved in CH₂Cl₂ (4 mL for **1**; 8 mL for **7**, 50 mM) under N₂ at -78°C stirred 10 min, and then was added slowly the solution of glycoside acceptor **2** (100 mg, 0.17 mmol) or **8** (100 mg, 0.32 mmol) in CH₂Cl₂ (1mL for **2**; 2 mL for **8**), at -78 to -60°C under N₂ stirred 1 to 6 h. and then were added acceptor **5** (130 mg, 0.26 mmol) or **9** (210 mg, 0.48 mmol) 、DPSO (40 mg, 0.2 mmol for **1**; 78 mg, 0.38 mmol for **7**) and Tf₂O (33 μ L, 0.2 mmol for **1**; 63 μ L, 0.38 mmol for **7**) at -60°C stirred 16 h. Upon completion of glycosylation as judged by TLC, the reaction was quenched with addition of few drops of satd. NaHCO₃, The resulting solution was then filtered through celite, and filtrate was washed with water (20 mL \times 2), brine (20 mL \times 1), dried (MgSO₄), filtered, and then concentrated for purification with medium pressure liquid chromatography over silica gel (230-400 mesh) (Elution: EtOAc/hexane = 1:4) to furnishing 6-chlorohexyl 3,6-di-*O*-benzyl-2-azido-2-deoxy-4-*O*-[3-*O*-acetyl-6-*O*-benzyl-2-(trichloroethyloxycarbonyl)-4-*O*-(2-*O*-benzyl-4,6-*O*-benzylidene-3-*O*-*p*-methoxy

benzyl- β -D-mannopyranosyl)- β -D-glucopyranosyl]- β -D-glucopyranoside **6** (50 mg, 20% over two steps) or (3-chloropropyl) 2-*O*-benzyl-4,6-*O*-benzylidene-[2,3-*O*-isopropylidene-4-*O*-(2,3-di-*O*-benzyl-4,6-*O*-benzylidene- β -D-mannopyranosyl)- α -L-rhamnopyranosyl]- β -D-galactopyranoside **10** (104 mg, 30% over two steps).

3.2.1.3 C. β -Mannosylation with molar equivalent of TMSOTf using trichloroacetimidate donor

To the solution of mannosyl imidate **11** (178 mg, 0.3 mmol) and acceptor **12** (100 mg, 0.2 mmol) were dissolved in CH₂Cl₂ (4 mL) at -70°C under N₂ stirred 10 min, and then was added TMSOTf (5 μ L, 0.03 mmol) stirred 2 h. Upon completion of β -mannosylation as judged by TLC, the reaction was quenched with addition of few drops of satd. NaHCO₃. The resulting solution was then filtered through celite, and filtrate was washed with water (20 mL \times 2), brine (20 mL \times 1), dried (MgSO₄), filtered, and then concentrated for column chromatography purification (Elution: EtOAc/hexane = 1:8) furnishing (2,6-dimethylphenyl) 2-azido-3,6-di-*O*-benzyl-2-deoxy-4-*O*-(2,3-di-*O*-benzyl-4,6-*O*-benzylidene-D-mannopyranosyl)-1-thio- β -D-glucopyranoside **13** (140 mg, 75% $\alpha/\beta = 1: 6$).

3.2.1.4 D. One-pot glycosylation of trisaccharide with equivalent of TMSOTf using trichloroacetimidate donor

To the solution of mannosyl imidate **11** (178 mg, 0.3 mmol for **12**; 264 mg, 0.46 mmol for **15**) and acceptor **12** (100 mg, 0.2 mmol) or acceptor **15** (100 mg, 0.31 mmol) were dissolved in CH₂Cl₂ (4 mL) at -70°C under N₂ stirred 10 min, and then was added TMSOTf (5 μL, 0.03 mmol) stirred 1 to 2 h, and then were added acceptor **5** (121 mg, 0.24 mmol, using procedure E) or acceptor **9** (162 mg, 0.37 mmol), TMSOTf (5 μL, 0.03 mmol) and NIS (68 mg, 0.3 mmol) at -40 to -20°C stirred 4 h. Upon completion of glycosylation as judged by TLC, the reaction was quenched by addition of few drops of satd. NaHCO₃ and small pieces of solid Na₂S₂O₃ followed by vigorously stirring for ca. 30 min. The resulting solution was then filtered through celite, and filtrate was washed with water (20 mL × 2), brine (20 mL × 1), dried (MgSO₄), filtered, and then concentrated for purification with medium pressure liquid chromatography over silica gel (230-400 mesh) Elution: EtOAc/hexane = 1:4 or 1:8) furnishing (1-chlorohexyl) 2-azido-3,6-di-*O*-benzyl-2-deoxy-4-*O*-[2-azido-3,6-di-*O*-(2,3-di-*O*-benzyl-2-deoxy-4-*O*-(2,3-di-*O*-benzyl-4,6-*O*-benzylidene-D-mannopyranosyl)-β-D-glucopyranosyl]-β-D-glucopyranoside **14** (117 mg, 45% over two steps) or (3-chloropropyl) 2-*O*-benzyl-4,6-*O*-benzylidene-[2,3-*O*-isopropylidene-4-*O*-(2,3-di-*O*-benzyl-4,6-*O*-benzylidene-β-D-mannopyranosyl)-α-L-rhamnopyranosyl]-β-D-galactopyranoside **10** (114 mg, 35% over two steps).

3.2.1.5 E. Low concentration 1,2-*trans* β -selective glycosylation

To the solution of thioglycoside donor (1.0 mol equiv) and acceptor (2.0 mol equiv) were dissolved in $\text{CH}_2\text{Cl}_2/\text{MeCN}/\text{EtCN}$ (1:2:1, 10 mM), and suspended 4 Å MS (500 mg) into the solution of mixture under N_2 at -70°C after stirred 10 min, were added NIS (1.2 mol equiv) and TMSOTf (0.15 mol equiv) stirred 4 h. Upon completion of glycosylation as judged by TLC, the reaction was quenched by addition of few drops of satd. NaHCO_3 and small pieces of solid $\text{Na}_2\text{S}_2\text{O}_3$ followed by vigorously stirring for ca. 30 min. The resulting solution was then filtered through celite, and filtrate was washed with water (20 mL \times 2), brine (20 mL \times 1), dried (MgSO_4), filtered, and then concentrated for purification with chromatography to obtain products

3.2.1.6 F. Rate dependent inverse-addition procedure for preparation of disaccharide thioglycoside

Mixture of acceptor (1.0 mol equiv) and 4 Å MS-AW (300 mg) in CH_2Cl_2 (50 mM) were stirred in 50 mL pear-shaped RB flask (flask A) for 10 min at bath temperature -50°C under N_2 , which was followed by treatment with trimethylsilyl trifluoromethanesulfonate (TMSOTf) (0.1 mol equiv). After then, D-mannosyl imidate donor (1.5 mol equiv) dissolved in CH_2Cl_2 (0.25 M) was injected to flask A at 0.2, 0.07 or 0.035

(for **2** or **18**); 0.4 or 0.14 (for **19**, **15**) mLmin⁻¹. Upon completion of glycosylation, the reaction was quenched with addition of few drops of Et₃N. The resulting mixture was filtered over celite, and the filtrate was then concentrated for medium pressure liquid chromatography purification over silica gel (230-400 mesh) (Elution: EtOAc/hexane + % CH₂Cl₂) to yield disaccharide **3**, **20**, **21** or **23**.

3.2.1.7 G. Preparation of trisaccharide with sequential glycosylation approach

Mixture of acceptor (1.0 mol equiv) and 4 Å MS-AW (300 mg) in CH₂Cl₂ (50 mM) was stirred in 50 mL of pear-shaped RB flask for 10 min at -50 °C under N₂, to which was added TMSOTf(0.1 mol equiv). To the mixture of acceptor and TMSOTf, 0.25 M of D-mannosyl imidate donor (1.5 mol equiv) was added via calibrated syringe pump at 0.2 (for **2**) or 0.4 (for **15**) mLmin⁻¹. Upon completion of glycosylation, the reaction was quenched with addition of few drops of Et₃N, and the mixture was filtered through celite. The filtrate was then washed with water (20 mL × 1), brine (20 mL × 1), dried over MgSO₄, filtered, and concentrated to give crude disaccharide. After drying under *vacuo* for couple of hours, crude disaccharide, was dissolved in CH₂Cl₂ (50 mM), to which were added acceptor **5** or **15** (1.2 mol equiv) and 4 Å MS-AW (500 mg) at -20°C for 10 min under N₂. After then, the mixture was treated with NIS (1.2 mol equiv) and TMSOTf(0.1 mol equiv), the resulting mixture was stirred from -40°C to rt for 16 h under N₂. Upon completion of

glycosylation, the reaction was quenched by addition of few drops of satd. NaHCO_3 and small pieces of $\text{Na}_2\text{S}_2\text{O}_3$. Followed by vigorous stirring for ca. 30 min, the mixture was filtered through celite, and the filtrate was concentrated to purification with medium pressure liquid chromatography purification over silica gel (230-400 mesh) (Elution: EtOAc/hexane + % CH_2Cl_2) to yield trisaccharide **6** or **10**

3.2.1.8 H. Deacetalation procedure

Crude residue **6** was treated with 90% aqueous acetic acid (1.0 mL) and stirring at 60°C for 1 h to remove the acetal function. After then, the mixture was concentrated for medium pressure liquid chromatography purification over silica gel (230-400 mesh) (Elution: EtOAc/hexane 1:1 + 1% MeOH) furnishing the target trisaccharide diol **22** (90 mg, 40% over three steps from **2**).

3.2.2 Construction of building blocks and di-, tri-saccharide

Preparation of tolyl 3-O-acetyl-6-O-benzyl-2-deoxy-2-(trichloroethyloxycarbonyl)-1-thio- β -D-glucopyranoside **2:**

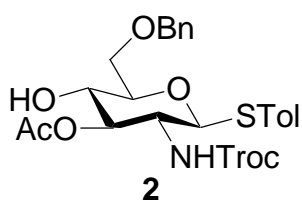

GlcNAc acceptor **2** was prepared according to literature procedure and was obtained as white glassy solid.^[11] For compound **2**, $R_f = 0.25$ (TLC developing solution: EtOAc/hexane = 1/2); ^1H NMR (300 MHz, CDCl_3): $\delta = 7.48\text{-}7.30$ (m, 7H), 7.08 (d, $J = 7.9$ Hz, 2H), 5.44 (d, $J = 9.5$ Hz, 1H; NH), 5.06 (dd, $J = 10.0, 9.3$ Hz, 1H), 4.83 (d, $J = 12.1$ Hz, 1H; CH_2CCl_3), 4.72 (d, $J = 12.1$ Hz, 1H; CH_2CCl_3), 4.68 (d, $J = 10.5$ Hz, 1H; H-1), 4.58 (dd, $J = 12.1, 2.4$ Hz, 1H; benzyl- CH_2), 3.81 (d, $J = 4.6$ Hz, 2H), 3.78-3.63 (m, 2H), 3.56 (dt, $J = 9.2, 4.4$ Hz, 1H), 3.17 (br, 1H; OH), 2.33 (s, 3H; ArCH_3), 2.08 (s, 3H; CH_3CO); ^{13}C NMR (75 MHz, CDCl_3): $\delta = 172.2$ (C=O), 154.6 (OC=O), 138.7, 138.0, 133.5, 130.1, 129.0, 128.9, 128.3, 128.2, 128.1, 95.9 (CCl_3), 87.6 (C-1), 78.6, 77.6, 76.6, 74.9, 74.1, 70.8, 70.5, 55.1, 21.5 (CH_3), 21.3 (CH_3).

Preparation of tolyl 3-*O*-acetyl-6-*O*-benzyl-2-deoxy-4-*O*-(2-*O*-benzyl-4,6-*O*-benzylidene-3-*O*-*p*-methoxybenzyl-D-mannopyranosyl)-2-(trichloroethyloxycarbonyl)-1-thio- β -D-glucopyranoside **3:**

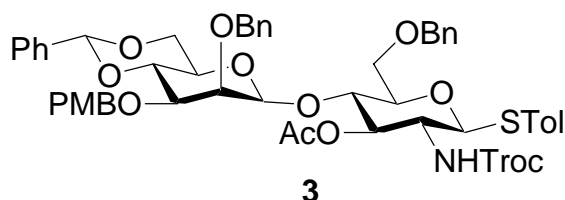

Disaccharide **3** was prepared according to procedure A (90 mg,

50%) or procedure F (105 mg, 60%) and was obtained as white glassy solid. For β -anomer of disaccharide thioglycoside **3**, $R_f = 0.22$ (TLC developing solution: EtOAc/hexane = 1:4); $[\alpha]_D^{27} = -30.7$ ($c = 0.63$, CHCl_3); $^1\text{H NMR}$ (500 MHz, CDCl_3): $\delta = 7.50$ (d, $J = 7.2$ Hz, 2H), 7.44 (d, $J = 7.8$ Hz, 2H), 7.42–7.22 (m, 15H), 7.09 (d, $J = 7.9$ Hz, 2H), 6.86 (d, $J = 8.3$ Hz, 2H), 5.58 (s, 1H; benzylidene-CH), 5.35 (d, $J = 9.3$ Hz, 1H), 5.17 (t, $J = 9.5$ Hz, 1H), 4.84 (d, $J = 12.0$ Hz, 1H), 4.79–4.62 (m, 5H), 4.56 (dd, $J = 22.9, 11.9$ Hz, 2H), 4.42 (d, $J = 12.0$ Hz, 2H), 4.28 (dd, $J = 10.1, 4.5$ Hz, 1H), 4.09 (t, $J = 9.5$ Hz, 1H), 3.89 (t, $J = 9.2$ Hz, 1H), 3.84–3.77 (m, 4H), 3.72 (d, $J = 9.8$ Hz, 1H), 3.67 (d, $J = 8.4$ Hz, 2H), 3.54 (d, $J = 10.9$ Hz, 1H), 3.44 (d, $J = 7.1$ Hz, 1H), 3.18 (d, $J = 4.2$ Hz, 1H; H⁵),^[50] 2.33 (s, 3H; ArCH_3), 2.01 (s, 3H; $\text{CH}_3\text{C}=\text{O}$); $^{13}\text{C NMR}$ (125 MHz, CDCl_3): $\delta = 171.3$ (C=O), 159.5 (COCH_3), 154.6 (OC=O), 138.8, 138.7, 138.0, 137.8, 134.0, 130.8, 130.1, 129.5, 129.3, 128.9, 128.9, 128.6, 128.5, 128.4, 128.2, 128.0, 126.4, 114.1, 102.4 ($^1J_{\text{CH}} = 158.6$ Hz; C-1'), 101.8 (benzylidene-CH), 95.9 (CCl_3), 87.3 ($^1J_{\text{CH}} = 158.4$ Hz; C-1), 79.1, 78.9, 78.0, 77.7, 76.9, 76.3, 75.1, 74.9, 74.4, 73.9, 72.6, 68.9, 68.8, 67.8, 55.6, 55.3, 21.6 (CH_3), 21.4 (CH_3); HRMS (Bio-ToFII): calcd for $\text{C}_{53}\text{H}_{56}\text{Cl}_3\text{NO}_{13}\text{SNa}$ requires 1074.2436; found: $m/z = 1074.2430$ [$\text{M} + \text{Na}$]⁺.

Preparation of tolyl 2-O-benzyl-4,6-O-benzylidene-3-O-p-methoxybenzyl-1-thio- α -D-mannopyranoside **4:**

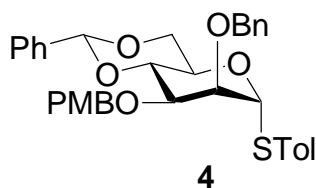

Thioglycoside side product **4** was prepared according to procedure A and obtained as a colorless oil. (10 mg, 10%). For compound **4**, $R_f = 0.75$ (TLC developing solution: EtOAc/hexane = 1:4); $^1\text{H NMR}$ (300 MHz, CDCl_3): $\delta = 7.63$ (dd, $J = 7.6, 1.8$ Hz, 2H), 7.54-7.37 (m, 12H), 7.19 (d, $J = 8.1$ Hz, 2H), 7.01-6.93 (m, 2H), 5.73 (s, 1H; benzylidene-CH), 5.54 (d, $J = 0.9$ Hz, 1H; H-1), 4.88-4.77 (m, 3H), 4.68 (d, $J = 11.8$ Hz, 1H), 4.45-4.27 (m, 3H), 4.14-4.04 (m, 2H), 4.02-3.91 (m, 1H), 3.87 (s, 3H; CH_3O), 2.41 (s, 3H; ArCH_3); $^{13}\text{C NMR}$ (75 MHz, CDCl_3): $\delta = 159.7$ (COCH_3), 138.4, 138.3, 138.1, 132.8, 130.9, 130.4, 130.3, 129.8, 129.3, 128.9, 128.6, 128.5, 128.3, 126.6, 114.2, 101.9 (benzylidene-CH), 87.9 (C-1), 79.5, 78.4, 76.2, 73.4, 73.1, 69.0, 65.9, 55.7 (COCH_3), 21.6 (CH_3); HRMS (Bio-ToFII): calcd for $\text{C}_{35}\text{H}_{37}\text{O}_6\text{SNa}$ requires 608.2209; found: $m/z = 608.2203$ $[\text{M} + \text{Na}]^+$.

Preparation of (6-chlorohexyl) 2-azido-3,6-di-*O*-benzyl-2-deoxy- β -D-glucopyranoside **5**:

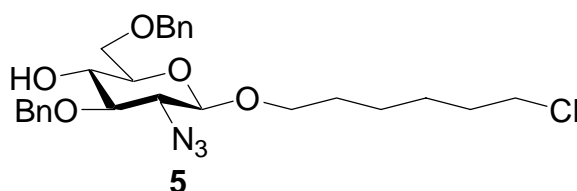

GlcNAc acceptor **5** was prepared according to literature procedure

and obtained as a colorless oil.^[51] For GlcNAc acceptor **5**, $R_f = 0.6$ (TLC developing solution: EtOAc/hexane = 1:4); $[\alpha]_D^{27} = -32.28$ ($c = 0.3$, CHCl_3); $^1\text{H NMR}$ (300 MHz, CDCl_3): $\delta = 7.43\text{-}7.29$ (m, 10H), 4.96 (d, $J = 11.4$ Hz, 1H; benzyl- CH_2), 4.81 (d, $J = 11.4$ Hz, 1H; benzyl- CH_2), 4.65 (dd, $J = 12.0, 4.8$ Hz, 2H; benzyl- CH_2), 4.31 (d, $J = 7.8$ Hz, 1H; H-1), 3.98-3.90 (m, 1H), 3.76 (d, $J = 6.6$ Hz, 1H), 3.68-3.52 (m, 4H), 3.46-3.29 (m, 2H), 3.26 (t, $J = 9.0$ Hz, 1H), 2.72 (br, 1H), 1.83-1.76 (m, 2H; CH_2), 1.72-1.64 (m, 2H; CH_2), 1.51-1.43 (m, 4H; CH_2); $^{13}\text{C NMR}$ (75 MHz, CDCl_3): $\delta = 138.5, 138.0, 129.0, 128.8, 128.5, 128.4, 128.2, 128.1, 102.6$ (C-1), 82.8, 75.4, 74.3, 74.1, 72.4, 70., 70.4, 66.1 (CH_2O), 45.4 ($\text{CH}_2\text{-Cl}$), 32.9, 29.7, 27.0, 25.6; HRMS-FAB: calcd for $\text{C}_{26}\text{H}_{35}\text{ClN}_3\text{O}_5$ requires 504.2260; found: $m/z = 504.2260$ $[\text{M} + \text{H}]^+$.

Preparation of 6-chlorohexyl 3,6-di-*O*-benzyl-2-azido-2-deoxy-4-*O*-[3-*O*-acetyl-6-*O*-benzyl-2-(trichloroethoxycarbonyl)-4-*O*-(2-*O*-benzyl-4,6-*O*-benzylidene-3-*O*-*p*-methoxybenzyl- β -D-mannopyranosyl)- β -D-glucopyranosyl]- β -D-glucopyranoside **6:**

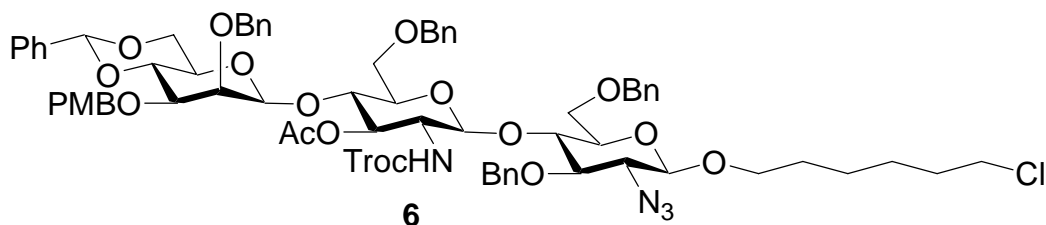

Trisaccharide **6** was prepared according to procedure B (50 mg, 20% over two steps) or procedure G (300 mg, 70% over two steps), obtained

as a colorless oil. The crude trisaccharide **6**: $R_f = 0.25$ (TLC developing solution: EtOAc/Hexane = 1/4 + 2% MeOH); $[\alpha]_D^{27} = -37.2$ ($c = 0.11$, CHCl_3); $^1\text{H NMR}$ (300 MHz, CDCl_3): $\delta = 7.66\text{--}7.22$ (m, 27H), 6.86 (d, $J = 8.7$ Hz, 2H), 5.58 (s, 1H), 5.04 (d, $J = 11.7$ Hz, 1H), 4.91–4.57 (m, 8H), 4.49 (d, $J = 11.9$ Hz, 1H), 4.42 (d, $J = 12.2$ Hz, 1H), 4.36 (s, 1H), 4.33–4.18 (m, 3H), 4.15 (d, $J = 12.4$ Hz, 2H), 4.07 (t, $J = 9.4$ Hz, 1H), 3.99–3.82 (m, 4H), 3.80 (s, 3H), 3.78–3.70 (m, 1H), 3.68–3.47 (m, 6H), 3.40–3.06 (m, 3H), 2.02 (s, 3H), 1.86–1.72 (m, 4H), 1.71–1.57 (m, 2H), 1.51–1.44 (m, 4H).

Preparation of tolyl 2,3-*O*-isopropylidene-1-thio- α -L-rhamnopyranoside **8**:

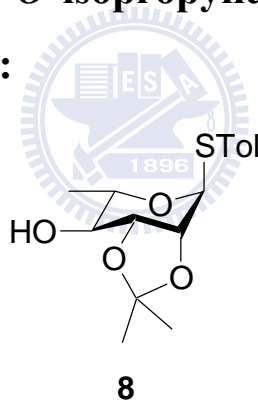

Thioglycoside **8** was prepared according to literature procedure and was obtained as white glassy solid.^[52] For thioglycoside **7**: $R_f = 0.35$ (TLC developing solution: EtOAc/Hexane = 1/6); $^1\text{H NMR}$ (300 MHz, CDCl_3): $\delta = 7.37$ (d, $J = 8.1$ Hz, 2H), 7.13 (d, $J = 8.3$ Hz, 2H), 5.67 (s, 1H), 4.34 (d, $J = 5.5$ Hz, 1H), 4.16–4.03 (m, 2H), 3.45 (ddd, $J = 9.8, 7.6, 3.9$ Hz, 1H), 2.62 (d, $J = 3.9$ Hz, 1H), 2.33 (s, 3H), 1.53 (s, 3H), 1.37 (s, 3H), 1.24 (d, $J = 6.2$ Hz, 3H); $^{13}\text{C NMR}$ (75 MHz, CDCl_3): $\delta = 137.8$,

132.5, 129.8, 129.4, 109.6, 84.0, 78.3, 76.4, 75.1, 66.8, 28.1, 26.3, 21.1, 17.0.

Preparation of (3-chloropropyl) 2-*O*-benzyl-4,6-*O*-benzylidene- β -D-galactopyranoside **9**:

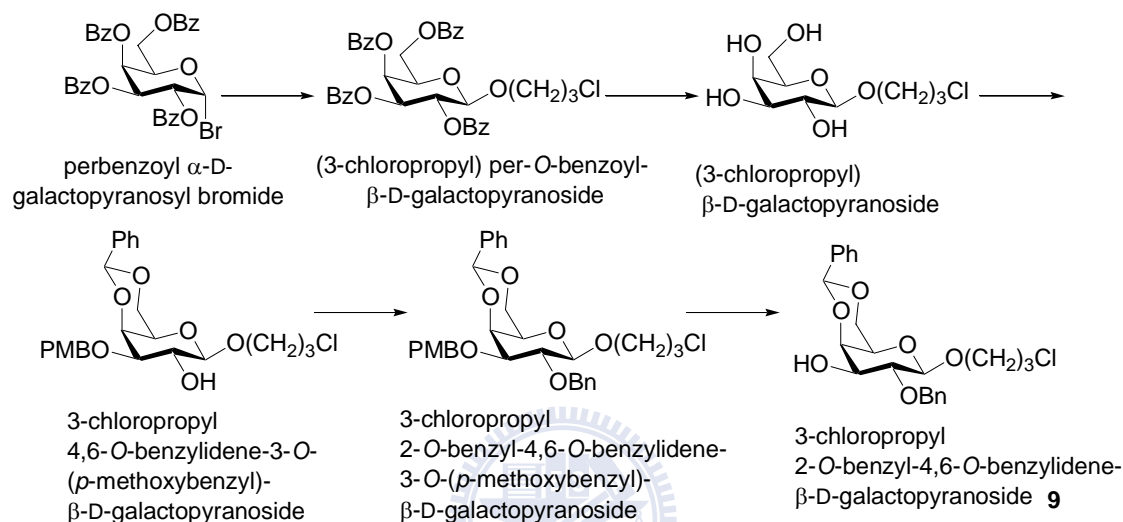

Perbenzoyl galactopyranosyl bromide^[53] (4.7 g, 7.0 mmol), 3-chloropropanol (3.1 mL, 36 mmol), 4 Å MS-AW (10g) were suspended in CH₂Cl₂ (50.0 mL) under N₂ at -20°C. After stirring for 10 min, AgOTf (2.2 g, 8.56 mmol) was added to the mixture, and followed by stirring from -20°C to rt for 2.5 h. Upon completion of glycosylation, the mixture was filtered over celite and the filtrate was washed with satd. NaHCO₃ (100 mL \times 2), water (100 mL \times 1), brine (100 mL \times 1), dried (MgSO₄), filtered, and then concentrated for column chromatography purification (Elution: EtOAc/hexane = 1:2) to yield (3-chloropropyl) per-*O*-benzoyl- β -D-galactopyranoside (4.1 g, 85%). To a solution of (3-chloropropyl) galactopyranoside (4.1 g, 6.07 mmol) in MeOH (30.0 mL, 0.2 M) was

added freshly cut Na_(s) (14.0 mg, 0.61 mmol) and the solution was stirred under N₂ at rt for 1 h. Upon completion of debenzylation, the mixture was neutralized with IR-120 H⁺ resin, which was subsequently removed by filtration. The resulting filtrate was concentrated to give unprotected (3-chloropropyl) β-D-galactopyranoside (1.5 g, 95%). To a mixture of (3-chloropropyl) β-D-galactopyranoside (1.5 g, 5.80 mmol) and C₆H₅CH(OMe)₂ (1.7 mL, 11.5 mmol) in CH₃CN (30 mL), TsOH (220 mg, 1.20 mmol) was added. The mixture was stirred at rt under N₂ for 1 hr. Upon completion of acetal formation, reaction was quenched with addition of few drops of Et₃N, and the mixture was then concentrated for precipitation in EtOAc/hexane mixture to obtain 3-chloropropyl 4,6-*O*-benzylidene protected α-D-galactopyranoside (1.57 g, 80%). To a solution of 4,6-*O*-benzylidene-1-β-D-galactopyranoside (1.57 g, 4.55 mmol) in benzene (23 mL), Bu₂SnO (1.7 g, 6.80 mmol) was added. The mixture was refluxed for 10 h with Dean–Stark trap at bath temperature of 105°C. After then, the temperature was adjusted to 70°C, and PMBCl (930 μL, 6.80 mmol) and TBAI (2.5 g, 6.80 mmol) were added to the mixture, which was stirred at 70°C for 6 h. Upon completion of alkylation, the mixture was diluted with EtOAc, which was sequentially washed with satd. NaHCO₃ (100 mL × 1), satd. Na₂S₂O₃ (100 mL × 1), water (100 mL × 1), brine (100 mL × 1), dried (MgSO₄), filtered through sea sand to remove tin derived byproducts, and then concentrated for column chromatography purification (Elution: EtOAc/hexane = 1:2) yielding 3-chloropropyl 4,6-*O*-benzylidene-3-*O*-*p*-methoxybenzyl-β-D-galactopyranoside (1.58 g, 75%). To a solution of 3-chloropropyl-4,6-*O*-benzylidene-3-*O*-*p*-methoxybenzyl-β-D-galactopyranoside (1.58 g,

3.40 mmol) in CH₃CN (17.0 mL), benzyl bromide (608 μL, 5.12 mmol) was added at bath temperature of 0°C and the mixture was stirred for 10 min. After then, 60% NaH (205 mg, 5.12 mmol) was added and the mixture was stirred from 0°C to rt for 1.5 h. Upon completion of alkylation, the mixture was diluted with EtOAc and washed with water (100 mL × 2), brine (100 mL × 1), dried (MgSO₄) filtered, and then concentrated for column chromatography purification (Elution: EtOAc/hexane = 1:6) to give 3-chloropropyl 2-*O*-benzyl-4,6-*O*-benzylidene-3-*O*-*p*-methoxybenzyl-β-D-galactopyranoside (1.7 g, 90%). To a solution of 3-chloropropyl 2-*O*-benzyl-4,6-*O*-benzylidene-3-*O*-*p*-methoxybenzyl-β-D-galactopyranoside (1.7 g, 3.07 mmol) in 19:1 CH₂Cl₂/H₂O (15 mL), dichlorodicyano quinone (DDQ) (1.05 g, 4.60 mmol) was added at bath temperature of 0°C and the mixture was stirred for 30 min. Upon complete removal of PMB function, the mixture was washed with satd. NaHCO₃ (100 mL × 1), Na₂S₂O₃ (100 mL × 1), water (100 mL × 1), brine (100 mL × 1), dried (MgSO₄) filtered, and then concentrated for column chromatography purification (Elution: EtOAc/hexane = 1:2) to yield target 3-chloro propyl 2-*O*-benzyl-4,6-*O*-benzylidene-β-D-galactopyranoside **9** as white amorphous solid (935 mg, 70%). For galactopyranoside **9**, *R*_f = 0.3 (TLC developing solution: EtOAc/hexane = 1:2); [α]_D²⁷ = +3.8 (*c* = 0.20, CHCl₃); ¹H NMR (300 MHz, CDCl₃): δ = 7.59-7.50 (m, 2H), 7.45-7.29 (m, 8H), 5.57 (s, 1H; benzylidene-CH), 4.95 (d, *J* = 11.2 Hz, 1H), 4.75 (d, *J* = 11.2 Hz, 1H), 4.42 (d, *J* = 7.6 Hz, 1H; H-1), 4.34 (dd, *J* = 12.4, 1.4 Hz, 1H), 4.24-4.19 (m, 1H), 4.16-4.04 (m, 2H), 3.84-3.59 (m, 5H), 3.44 (d, *J* = 1.0 Hz, 1H), 2.60 (d, *J* = 6.4 Hz, 1H; OH), 2.31-1.97 (m, 2H; CH₂); ¹³C NMR (75

MHz, CDCl₃): δ = 138.8, 137.9, 129.6, 128.8, 128.6, 128.3, 128.1, 126.8, 103.9 ($^1J_{\text{CH}} = 155.2$ Hz; C-1), 101.7 (benzylidene-CH), 79.7, 75.9, 75.3, 72.8, 69.5, 66.9, 66.7, 42.2, 33.1; HRMS (Bio-ToFII): calcd for C₂₃H₂₇ClO₆Na requires 457.1394; found: $m/z = 457.1388$ [M + Na]⁺.

Preparation of (3-chloropropyl) 2-*O*-benzyl-4,6-*O*-benzylidene-[2,3-*O*-isopropylidene-4-*O*-(2,3-di-*O*-benzyl-4,6-*O*-benzylidene- β -D-mannopyranosyl)- α -L-rhamnopyranosyl]- β -D-galactopyranoside **10:**

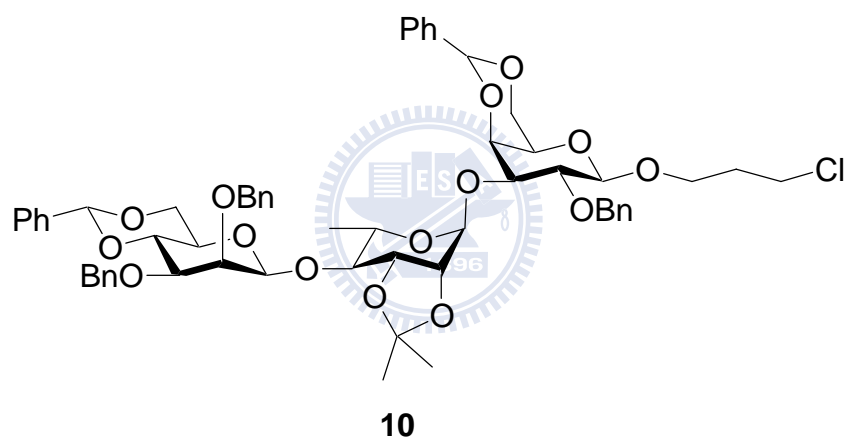

Trisaccharide **10** was prepared according to procedure B (50 mg, 20% over two steps), procedure D (114 mg, 35% over two steps) or procedure G (272 mg, 70% over two steps) and obtained as a colorless oil. For trisaccharide **17**, $R_f = 0.20$ (TLC developing solution: EtOAc/hexane = 1:4 + 20% CH₂Cl₂); $[\alpha]_D^{27} = -3.33$ ($c = 0.30$, CHCl₃); $^1\text{H NMR}$ (300 MHz, CDCl₃): $\delta = 7.54$ - 7.19 (m, 25H), 5.71-5.48 (m, 2H), 5.25 (s, 1H; H''-1), 5.01 (s, 1H; H'-1), 4.95-4.81 (m, 3H), 4.75-4.67 (m, 2H), 4.63 (d, $J = 9.1$ Hz, 1H), 4.47 (d, $J = 7.2$ Hz, 1H; H-1), 4.35 (t, $J = 8.3$ Hz, 2H),

4.32-4.19 (m, 3H), 4.18-4.06 (m, 3H), 4.02-3.91 (m, 3H), 3.85-3.59 (m, 7H), 3.46 (d, $J = 8.1$ Hz, 1H), 3.33 (td, $J = 9.8, 4.9$ Hz, 1H), 2.28-2.01 (m, 2H; CH₂), 1.52 (s, 3H; CH₃), 1.34 (s, 6H; CH₃); ¹³C NMR (75 MHz, CDCl₃): $\delta = 138.9, 138.8, 138.7, 138.1, 137.9, 129.5, 129.2, 128.88, 128.81, 128.7, 128.65, 128.60, 128.5, 128.4, 128.3, 128.28, 128.23, 128.1, 127.9, 127.8, 126.69, 126.65, 126.5, 126.4, 109.6$ (C(CH₃)₂), 104.0 (¹ $J_{\text{CH}} = 156.5$ Hz; C-1), 101.8 (benzylidene-CH), 101.7 (benzylidene-CH), 100.6 (¹ $J_{\text{CH}} = 157.5$ Hz; C-1''), 100.5 (¹ $J_{\text{CH}} = 167.9$ Hz; C-1'), 81.6, 79.0, 78.5, 78.3, 78.2, 77.67, 76.65, 76.5, 76.4, 75.7, 75.2, 72.4, 69.6, 69.0, 68.0, 66.7, 66.6, 65.2, 42.2, 33.1, 28.2, 26.8, 18.2; HRMS (Bio-ToFII): calcd for C₅₉H₆₇ClO₁₅Na requires 1073.4066; found: $m/z = 1073.4061$ [M + Na]⁺.

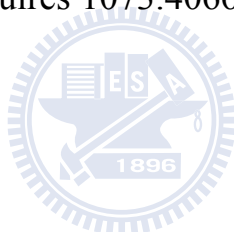

Preparation of 2,3-di-*O*-benzyl-4,6-*O*-benzylidene-D-mannopyranosyl trichloroacetimidate (mannosyl imidate donor) **11:**

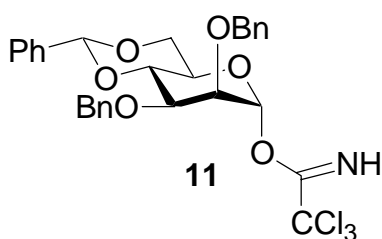

Mannosyl imidate donor **11** was prepared according to literature procedure and was obtained as a colorless syrup.^[54] For α -anomer of compound **11**, $R_f = 0.7$ (TLC developing solution: EtOAc/hexane = 1:4); ¹H NMR (300 MHz, CDCl₃): $\delta = 8.65$ (s, 1H; imidate-H), 7.66-7.56 (m,

2H), 7.53-7.29 (m, 13H), 6.36 (d, $J = 1.6$ Hz, 1H; H-1), 5.73 (s, 1H; benzylidene-CH), 4.89 (dt, $J = 17.9, 8.1$ Hz, 3H), 4.74 (d, $J = 12.2$ Hz, 1H), 4.48-4.34 (m, 2H), 4.08 (ddd, $J = 14.8, 7.5, 3.8$ Hz, 2H), 4.01-3.88 (m, 2H); ^{13}C NMR (75 MHz, CDCl_3): $\delta = 160.7$ (C=NH), 138.6, 138.1, 137.8, 129.3, 128.9, 128.8, 128.7, 128.6, 128.5, 128.3, 128.3, 128.1, 126.4, 101.9 (benzylidene-CH), 96.9 (C-1), 91.2, 78.8, 75.6, 75.6, 74.0, 73.7, 68.9, 67.3.

Preparation of (2,6-dimethylphenyl) 2-azido-3,6-di-*O*-benzyl-2-deoxy-1-thio- β -D-glucopyranoside 12:

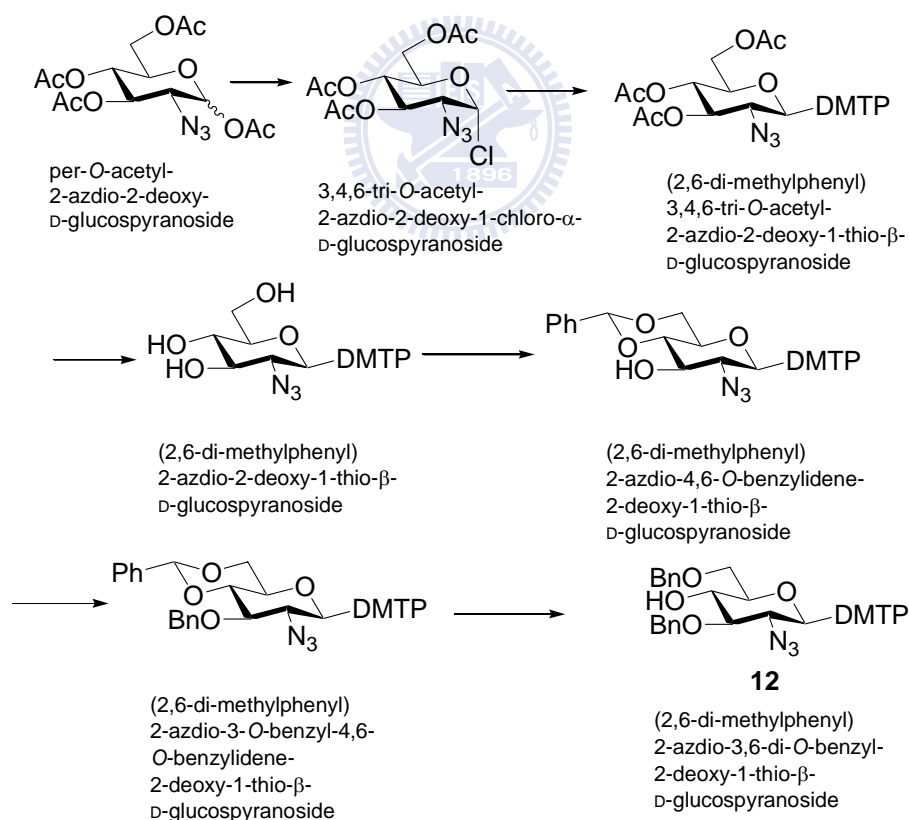

To a solution of per-*O*-acetyl-2-azido-2-deoxy-glucospyranoside^[55]

(100 mg, 0.27 mmol) in DMF (2.0 mL), Upon further addition of $\text{H}_4\text{N}_2\cdot\text{HOAc}$ (2.2 g, 23.9 mmole), the mixture was stirred at room temperature under N_2 for 1h. Upon completion of reaction. The reacting mixture was diluted with EtOAc (20 mL) and washed with 1N $\text{HCl}_{(\text{aq})}$ (10 mL \times 1), sat. Na_2HCO_3 (10 mL \times 2), water (10 mL \times 1), brine (20 mL \times 1), dried over MgSO_4 , filtered and concentrated to obtained crude 3,4,6-*O*-acetyl-2-azido-2-deoxy-D-glucopyranoside. To a solution of TCT (60 mg, 0.32 mmole) and DMF (0.83 mL, 1.1 mmole), the mixture was stirred at room temperature under N_2 for 30 mins, upon further added 3,4,6-*O*-acetyl-2-azido-2-deoxy-D-glucopyranoside (89 mg, 0.27 mmol) dissolved in DCE (1.0 mL), and the mixture stirred at 60°C for 3h under N_2 . Upon completion of reaction. The reacting mixture was diluted with EtOAc (20 mL) and washed with sat. Na_2CO_3 (10 mL \times 2), water (10 mL \times 1), brine (20 mL \times 1), dried over MgSO_4 , filtered and concentrated for column chromatography over silica gel to obtained 3,4,6-*O*-acetyl-2-azido-1-chloro-2-deoxy- α -D-glucopyranoside (73 mg, 76%). To a solution of 3,4,6-*O*-acetyl-2-azido-1-chloro-2-deoxy- α -D-glucopyranoside (80 mg, 0.23 mmole), TBAH (8 mg, 0.02 mmole), 1N $\text{Na}_2\text{CO}_3_{(\text{aq})}$ (1.2 mL, 1.14 mmole), and 2,6-DMTP (0.37 mL, 0.28 mmole) were dissolved in EtOAc (2.0 mL), and the mixture stirred at 40°C for 5h. Upon completion of reaction. The reacting mixture was diluted with EtOAc (20 mL) and washed with water (10 mL \times 2), brine (20 mL \times 1), dried over MgSO_4 , filtered and concentrated for column chromatography over silica gel to obtained (2,6-di-methylphenyl) 3,4,6-*O*-acetyl-2-azido-2-deoxy-1-thio- β -D-glucopyranoside (90 mg, 87%).

(2,6-Dimethylphenyl) 3,4,6-*O*-acetyl-2-azido-2-deoxy-1-thio- β -D-glucopyranoside (1.2 g, 2.6 mmol) was dissolved in MeOH (10 mL) at 0°C under N₂, which was followed by the addition of a piece of freshly cut sodium (cat. 6 mg). The mixture was stirred from 0°C to rt for 1 h and then neutralized with IR-120 H⁺. After filtration removal of resin and removal of solvent by rotary evaporator, the crude deacetylated product was dissolved in MeCN (10 mL), were added Bn(OMe)₂ (0.6 mL, 3.9 mmole), and TSOH (49 mg, 0.26 mmole) stirred at room temperature for 2h, And then neutralized with Et₃N (excess 2 mL) under ice bath and concentrated. The crude benzylidene product was dissolved in DMF (10mL) stirred at 0°C for 30 min under N₂, and then was added 60% NaH_(s) in oil (208 mg, 5.2 mmole) stirred 30 min, and added Bn-Br (0.6 mL, 5.2 mmole) stirred 2h. Upon completion of reaction. The reacting mixture was quenched with MeOH (5 mL), and diluted with EtOAc (100 mL) and washed with water (100 mL \times 2), brine (100 mL \times 1), dried over MgSO₄, filtered and concentrated for crystallation (EtOAc/Hexane 1:20) to obtained (2,6-di-methylphenyl) 2-azido-3-*O*-benzyl-4,6-*O*-benzylidene-2-deoxy-1-thio- β -D-glucopyranoside (1.1 g, 80%, over 3 steps). To a solution of (2,6-di-methylphenyl) 2-azido-3-*O*-benzyl-4,6-*O*-benzylidene-2-deoxy-1-thio- β -D-glucopyranoside (200 mg, 0.4 mmole), Et₃SiH (0.3 mL, 2.0 mmole) and 4Å MS-AW in CH₂Cl₂ (4 mL), and stirred at -10°C under N₂, after 30 min was added TFA (0.2 mL, 2.4 mmole) stirred 1h. Upon completion of reaction. The reacting mixture was diluted with EtOAc (20 mL) and washed with sat. NaHCO₃ (10 mL \times 2), water (10 mL \times 1), brine (20 mL \times 1), dried over MgSO₄, filtered and concentrated

for column chromatography over silica gel to obtain (2,6-dimethylphenyl) 2-azido-3,6-*O*-benzyl-2-deoxy-1-thio- β -D-glucopyranoside as colorless oil (172 mg, 85%). For (2,6-dimethylphenyl) 3,6-di-*O*-benzyl-2-azido-2-deoxy-4-*O*-1- β -D-thiogluco pyrano side **12**: $[\alpha]_D^{27} = + 2.42$ ($c = 2.1$, CHCl_3); $^1\text{H NMR}$ (300 MHz, CDCl_3): δ 7.41–7.31 (m, 10H; ArH), 7.24–7.15 (m, 3H; ArH), 4.99 (dd, $J = 11.1, 16.8$ Hz, 2H), 4.06 (dd, $J = 3.6, 12.0$ Hz, 2H), 4.28 (d, $J = 10.2$ Hz, 1H), 3.75–3.70 (m, 3H), 3.50 (t, $J = 9.3$ Hz, 1H), 3.37–3.25 (m, 2H), 2.84 (br, 1H), 2.64 ($2 \times \text{CH}_3$, 6H; $\text{CH}_3\text{C}=\text{O}$); $^{13}\text{C NMR}$ (75 MHz, CDCl_3) δ 144.7, 138.4, 138.1, 131.3, 129.7, 129.0, 128.9, 128.7, 128.6, 128.5, 128.2, 128.1, 89.5, 85.2, 78.1, 75.8, 74.1, 72.3, 70.8, 66.5, 22.9; HRMS–ESI: calcd for $\text{C}_{28}\text{H}_{31}\text{N}_3\text{O}_4\text{SNa}$ requires 528.1927; found: $m/z = 528.1928$ $[\text{M} + \text{Na}]^+$.



Preparation of (2,6-dimethylphenyl) 2-azido-3,6-di-*O*-benzyl-4-*O*-(2,3-di-*O*-benzyl-4,6-*O*-benzylidene-D-mannopyranosyl)-1-thio- β -D-glucospyranoside **13**

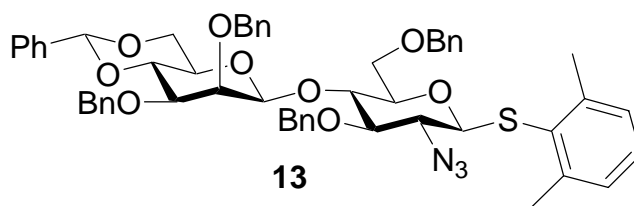

Disaccharide **13** was prepared according to procedure C (140 mg, 75%, $\alpha/\beta = 1:6$) obtained as a colorless oil. For (2,6-dimethylphenyl) 2-azido-3,6-di-*O*-benzyl-4-*O*-(2,3-di-*O*-benzyl-4,6-*O*-benzylidene- β -D-mannopyranosyl)-1-thio- β -D-glucospyranoside **13**, $R_f = 0.45$ (TLC

developing solution: EtOAc/hexane = 1:4); $[\alpha]_D^{27} = -4.95$ ($c = 2.00$, CHCl_3); $^1\text{H NMR}$ (300 MHz, CDCl_3): $\delta = 7.60\text{--}7.26$ (m, 28H), 5.58 (s, 1H), 5.20 (d, $J = 10.2$ Hz, 1H), 4.96–4.80 (m, 2H), 4.75–4.57 (m, 5H), 4.45–4.35 (m, 1H), 4.24–3.93 (m, 4H), 3.81 (d, $J = 2.9$ Hz, 1H), 3.60–3.44 (m, 6H), 3.29–3.11 (m, 2H), 2.66 (s, 6H); $^{13}\text{C NMR}$ (75 MHz, CDCl_3): $\delta = 144.8, 138.9, 138.8, 138.7, 138.1, 138.0, 131.1, 129.6, 129.2, 128.9, 128.7, 128.67, 128.61, 128.5, 128.3, 128.1, 128.0, 127.8, 126.4, 101.8, 101.7$ ($^1J_{\text{CH}} = 159.0$ Hz; C-1'), 88.8 ($^1J_{\text{CH}} = 157.0$ Hz; C-1), 84.1, 79.17, 79.13, 78.7, 77.3, 77.2, 75.8, 75.5, 74.0, 73.0, 69.0, 68.8, 67.8, 66.2, 22.9; LRMS–ESI: calcd for $\text{C}_{55}\text{H}_{57}\text{N}_3\text{O}_9\text{SNa}$ requires 958.37; found: $m/z = 958.31$ $[\text{M} + \text{Na}]^+$.

Preparation of (1-chlorohexyl) 2-azido-3,6-di-*O*-benzyl-2-deoxy-4-*O*-[2-azido-3,6-di-*O*-benzyl-4-*O*-(2,3-di-*O*-benzyl-4,6-*O*-benzylidene- β -D-mannopyranosyl)- β -D-glucospyranosyl]- β -D-glucospyranoside **14:**

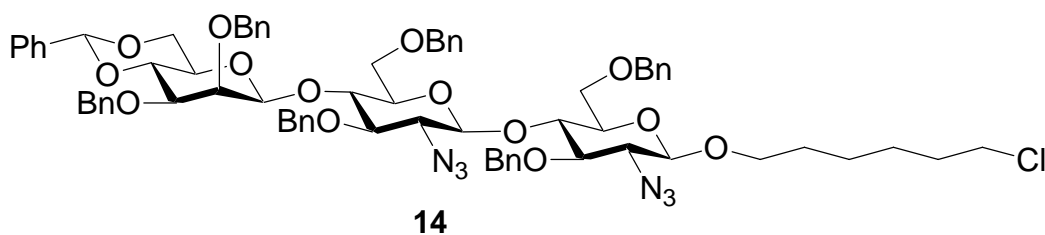

Trisaccharide **14** was prepared according to procedure D (117 mg, 45% over two steps) obtained as a colorless oil. For trisaccharide **14**, $R_f = 0.25$ (TLC developing solution: EtOAc/hexane = 1:4); $[\alpha]_D^{27} = -45.09$ ($c = 0.35$, CHCl_3); $^1\text{H NMR}$ (300 MHz, CDCl_3): $\delta = 7.54\text{--}7.14$ (m, 35H), 5.54 (s, 1H), 5.15 (d, $J = 10.3$ Hz, 1H), 5.04 (d, $J = 11.4$ Hz, 1H), 4.87 (d,

$J = 2.9$ Hz, 2H), 4.75 (dd, $J = 17.5, 12.4$ Hz, 3H), 4.66–4.52 (m, 3H), 4.49–4.39 (m, 2H), 4.30 (dd, $J = 21.3, 7.8$ Hz, 1H), 4.21–4.01 (m, 6H), 3.83 (d, $J = 10.2$ Hz, 1H), 3.73 (d, $J = 2.8$ Hz, 1H), 3.57–3.50 (m, 4H), 3.49–3.39 (m, 6H), 3.20 (t, $J = 9.3$ Hz, 1H), 3.11–2.99 (m, 2H), 1.89–1.76 (m, 2H), 1.75–1.58 (m, 4H), 1.49–1.39 (m, 4H); ^{13}C NMR (75 MHz, CDCl_3): $\delta = 138.92, 138.8, 138.4, 138.07, 138.01, 129.2, 128.97, 128.91, 128.8, 128.7, 128.6, 128.5, 128.4, 128.3, 128.2, 128.1, 128.0, 127.9, 127.8, 127.7, 126.4, 102.5$ ($^1J_{\text{CH}} = 158.4$ Hz; C-1), 101.7 ($^1J_{\text{CH}} = 159.0$ Hz; C-1'), 101.2 ($^1J_{\text{CH}} = 162.3$ Hz; C-1''), 82.0, 81.4, 79.0, 78.6, 77.7, 77.6, 77.3, 76.9, 75.5, 75.5, 75.4, 75.1, 74.8, 73.8, 73.7, 72.9, 70.3, 68.9, 68.8, 68.4, 67.7, 66.5, 66.4, 45.4, 32.9, 29.7, 27.0, 25.6; HRMS (Bio-ToFII): calcd for $\text{C}_{73}\text{H}_{81}\text{ClN}_6\text{O}_{14}\text{Na}$ requires 1323.5397; found: $m/z = 1323.5392$ $[\text{M} + \text{Na}]^+$.



Preparation of (2,6-dimethylphenyl)

2,3-*O*-isopropylidene-thio- α -L-rhamnopyranoside 15:

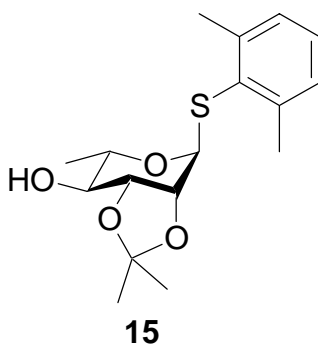

Unprotected (2,6-dimethylphenyl) 1-thio-L-rhamnopyranoside^[56] (8.5 g, 20 mmol), 2,2-dimethoxypropane (7.3 mL, 30 mmol) and

toluenesulfonic acid monohydrate (TSOH) (850 mg, 4.5 mmol) were dissolved in CH₃CN (225 mL), and stirred from 0°C to rt for 1.5 h. Upon completion of acetal formation, the mixture was diluted with EtOAc, followed by washing with satd. NaHCO₃ (200 mL × 2), water (200 mL × 1), brine (200 mL × 1), dried (MgSO₄) filtered, and then concentrated for column chromatography purification (Elution: EtOAc/hexane = 1:8) to yield thiorhamnoside **15**. **15** was further precipitated in EtOAc/hexane mixture to furnish white needle-like solid (8.7 g, 90%, α/β = 2:1). For α-anomer of thiorhamnoside **15** *R*_f = 0.5 (TLC developing solution: EtOAc/hexane = 1:4); [α]²⁷_D = -192.9 (*c* = 0.15, CHCl₃); ¹H NMR (300 MHz, CDCl₃): δ = 7.21-7.09 (m, 3H), 5.47 (s, 1H; H-1), 4.45 (dd, *J* = 5.4, 0.7 Hz, 1H), 4.17 (dd, *J* = 7.5, 5.5 Hz, 1H), 4.09-3.95 (m, 1H), 3.56-3.35 (m, 1H), 2.55 (d, *J* = 5.6 Hz, 6H; ArCH₃), 2.42 (d, *J* = 3.7 Hz, 1H; OH), 1.54 (s, 3H; CH₃), 1.40 (s, 3H; CH₃), 1.22 (d, *J* = 6.2 Hz, 3H; CH₃); ¹³C NMR (75 MHz, CDCl₃): δ = 143.4, 131.8, 129.2, 128.7, 110.0 (C(CH₃)₂), 84.6 (¹*J*_{CH} = 165.0 Hz; C-1), 78.7, 75.4, 68.3, 28.5, 26.8, 22.5, 17.4; HRMS (Bio-ToFII): calcd for C₁₇H₂₄O₄SNa requires 347.1293; found: *m/z* = 347.1288 [M + Na]⁺.

Preparation of 2-*O*-benzyl-4,6-*O*-benzylidene-3-*O*-*p*-methoxy benzyl-α-*D*-mannopyranosyl trichloroacetimidate **16:**

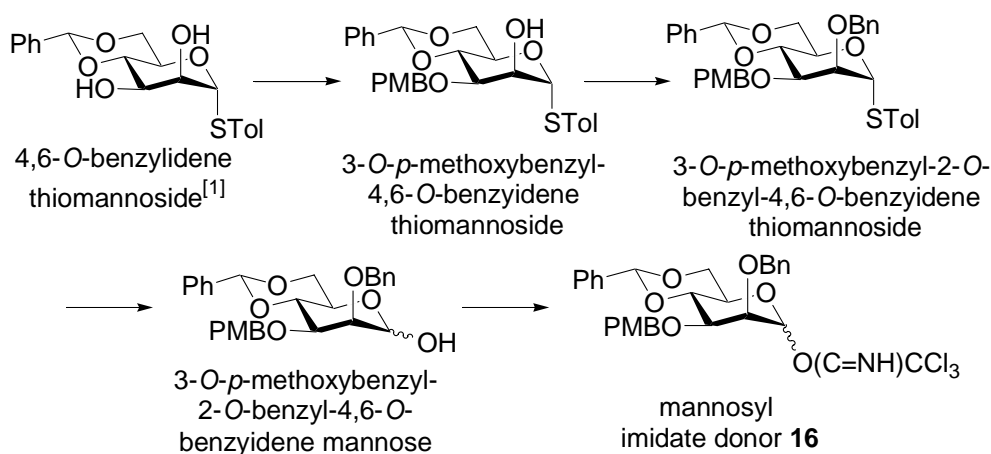

To a solution of 4,6-*O*-benzylidene thiomannoside^[58] (3.0 g, 8.01 mmol) in benzene (C₆H₆) (55 mL, 0.15 M), dibutyltin oxide (Bu₂SnO) (2.99 g, 12.0 mmol) was added, and the mixture was stirred under reflux with dean-stark trap at 105°C bath temperature for 10 h. Subsequently, the bath temperature was brought to 70°C, to which *p*-methoxybenzyl chloride (PMB-Cl) (1.6 mL, 12.0 mmol) and tetrabutylammonium chloride (TBAI) (4.4 g, 12.0 mmol) were added. The resulting mixture was stirred for additional 6 h and was then concentrated to a syrup residue, which was suspended in EtOAc. The EtOAc solution was washed with satd. NaHCO₃ (100 mL × 1), satd. Na₂S₂O₃ (100 mL × 1), water (100 mL × 1), brine (100 mL × 1), dried (MgSO₄) and filtered over sea sand (to remove tin derived side-products). The resulting filtrate was concentrated for column chromatography purification (Elution: EtOAc/hexane = 1:2) furnishing 3-*O*-*p*-methoxybenzyl-4,6-*O*-benzylidene thiomannoside (2.97 g, 75%). To a mixture of 3-*O*-*p*-methoxybenzyl-4, 6-*O*-benzylidene thiomannoside (2.97 g, 6.01 mmol) and benzyl bromide (1.07 mL, 9.01 mmol) in CH₃CN (30.0 mL)

was added 60% sodium hydride (NaH) (360 mg, 9.01 mmol), and the mixture was stirred at 0°C for 10 min and then stirred at rt for additional 1 h. Upon completion of alkylation as judged by TLC, the mixture was diluted with EtOAc and washed with water (100 mL × 2), brine (100 mL × 1), dried (MgSO₄), filtered, and then concentrated for column chromatography purification (Elution: EtOAc/hexane = 1:6) furnishing 2-*O*-benzyl-4,6-*O*-benzylidene-3-*O*-*p*-methoxybenzyl thiomannoside (3.2 g, 90%). A solution of thiomannoside obtained from the preceding step (2.8 g, 4.78 mmol) and *N*-bromosuccinimide (NBS) (3.4 g, 19.11 mmol) in 20:1 acetone/H₂O mixture (95.0 mL, 0.05 M) was stirred at bath temperature -5°C for 30 min. Upon completion of deprotection, a few drops of satd. NaHCO₃ and small pieces of solid Na₂S₂O₃ were added to the mixture, followed by vigorous stirring for ca. 10 min. The resulting mixture was washed with water (100 mL × 2), brine (100 mL × 1), dried (MgSO₄), filtered and then concentrated for column chromatography purification (Elution: EtOAc/hexane = 1:4) to furnish 3-*O*-*p*-methoxybenzyl-2-*O*-benzyl-4,6-*O*-benzylidene mannose (1.95 g, 85%). The mannose obtained was then dissolved in CH₂Cl₂ (20 mL, 0.2 M), to which were added trichloroacetonitrile (CCl₃CN) (1.6 mL, 16.2 mmol) and 1,8-diazabicyclo[5.4.0] undec-7-ene (DBU) (122 μL, 0.81 mmol). The mixture was stirred at -5°C for 1 h under N₂. Upon completion of imidate formation, the reaction mixture was washed with satd. NaHCO₃ (100 mL × 1), water (100 mL × 2), brine (100 mL × 1), dried (MgSO₄), filtered, and then concentrated for column chromatography purification over pre-neutralized silica gel (pre-flushed with 3% Et₃N in eluting solvent) with elution of 1:8 EtOAc/hexane

mixture giving 2-*O*-benzyl-4,6-*O*-benzylidene-3-*O*-*p*-methoxybenzyl-D-mannopyranosyl trichloroacetimidate (mannosyl imidate donor) **16** as a colorless syrup (2.14 g, 85%, α : β = 5:1). For α -anomer of **16**, R_f = 0.3 (TLC developing solution: EtOAc/hexane = 1/8); $[\alpha]_D^{27} = +15.2$ ($c = 14.50$, CHCl₃); ¹H NMR (300 MHz, CDCl₃): δ = 8.62 (s, 1H; imidate-H), 7.61-7.53 (m, 2H), 7.41 (m, 8H), 7.32-7.25 (m, 2H), 6.92-6.81 (m, 2H), 6.31 (d, $J = 1.6$ Hz, 1H; H-1), 5.70 (s, 1H; benzylidene-CH), 4.90-4.78 (m, 3H), 4.64 (dd, $J = 10.7, 4.3$ Hz, 1H), 4.43-4.29 (m, 2H), 4.03 (dt, $J = 3.8, 9.6$ Hz, 2H), 3.97-3.86 (m, 2H), 3.83 (s, 3H; CH₃O); ¹³C NMR (75 MHz, CDCl₃): δ = 160.2 (C=NH), 159.2 (COCH₃), 137.6, 137.3, 130.1, 129.5, 128.8, 128.3, 128.18, 128.13, 128.0, 127.8, 125.9, 113.6, 101.3 (benzylidene-CH), 96.4 (C-1), 90.7, 78.2, 75.1, 74.5, 73.5, 72.8, 68.4, 66.8, 55.1 (COCH₃); HRMS (Bio-ToFII): calcd for C₃₀H₃₀Cl₃NO₇Na requires 644.0986; found: $m/z = 644.0980$ [M + Na]⁺.

Preparation of *N*-(2-*O*-benzyl-4,6-*O*-benzylidene-3-*O*-*p*-methoxybenzyl-1- β -D-mannopyranosyl)-trichloroacetamide **17:**

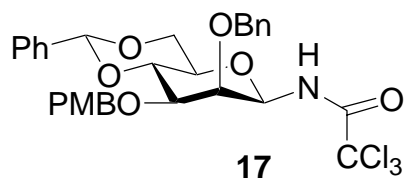

Monosaccharide **17** was prepared according to procedure F (10 mg, 10%) obtained as a colorless oil. For compound **17**, $R_f = 0.65$ (TLC

developing solution: EtOAc/hexane = 1:4); $[\alpha]_D^{27} = +17.3$ ($c = 0.75$, CHCl_3); $^1\text{H NMR}$ (300 MHz, CDCl_3): $\delta = 7.60\text{-}7.48$ (m, 3H), 7.48-7.30 (m, 10H), 6.98-6.89 (m, 2H), 5.67 (s, 1H; benzylidene-CH), 5.22 (dd, $J = 9.2, 1.35$ Hz, 1H; H-1), 5.15 (d, $J = 11.5$ Hz, 1H), 4.93 (d, $J = 11.7$ Hz, 1H), 4.75 (d, $J = 11.4$ Hz, 2H), 4.36 (dd, $J = 10.4, 4.9$ Hz, 1H), 4.22 (t, $J = 9.6$ Hz, 1H), 3.97-3.90 (m, 1H), 3.89-3.79 (m, 5H), 3.52 (td, $J = 9.8, 4.9$ Hz, 1H); $^{13}\text{C NMR}$ (75 MHz, CDCl_3): $\delta = 161.7$ (C=O), 159.8 (COCH_3), 137.7, 137.6, 130.4, 129.9, 129.4, 129.3, 128.9, 128.6, 126.4, 114.3, 101.9 (benzylidene-CH), 92.3 (CCl_3), 79.4 ($^1J_{\text{CH}} = 160.7$ Hz), 78.98, 77.9, 77.4, 77.0, 76.7, 75.9, 73.9, 69.4, 68.7, 55.7 (COCH_3); HRMS-FAB: calcd for $\text{C}_{30}\text{H}_{30}\text{NO}_7\text{Cl}_3$ requires 621.1088; found: $m/z = 621.1085$ $[\text{M}]^+$.

Rate dependent inverse-addition procedure for preparation of disaccharides **20** and **21**:

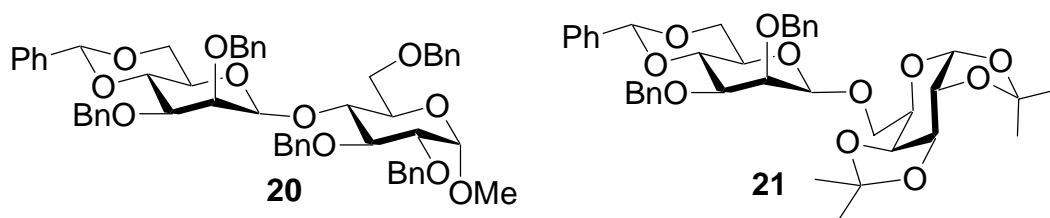

2,3,6-tri-*O*-benzyl-4-*O*-(2,3-di-*O*-benzyl-*D*-mannopyranosyl)- α -*D*-glucopyranoside **20** and 1,2,3,4-di-*O*-isopropylidene-6-*O*-(2,3-di-*O*-benzyl-4,6-benzylidene-*D*-mannopyranosyl)- α -*D*-galactopyranoside **21** was prepared according to procedure F (173 mg, 90%, $\alpha/\beta = 1/10$ for **20**; 244 mg, 92%, $\alpha/\beta = 1/2.3$ for **21**) obtained as a colorless oil. For β -anomer of disaccharide **20**, $R_f = 0.30$ (TLC developing solution: EtOAc/hexane = 1/3); $^1\text{H NMR}$ (300 MHz, CDCl_3): $\delta = 7.50$ (dt, $J = 8.0$,

4.3 Hz, 4H), 7.46-7.23 (m, 26H), 5.55 (s, 1H; benzylidene-CH), 5.08 (d, $J = 10.7$ Hz, 1H), 4.87-4.73 (m, 5H), 4.72-4.57 (m, 5H), 4.39 (s, 1H), 4.31 (d, $J = 12.1$ Hz, 1H), 4.15-4.03 (m, 2H), 3.96-3.84 (m, 2H), 3.67 (d, $J = 2.9$ Hz, 1H), 3.62 (dd, $J = 8.0, 4.8$ Hz, 1H), 3.58-3.52 (m, 1H), 3.49 (dd, $J = 11.1, 2.7$ Hz, 1H), 3.43 (s, 3H; CH₃O), 3.36 (dd, $J = 10.0, 2.9$ Hz, 2H), 3.08-3.01 (m, 1H); ¹³C NMR (75 MHz, CDCl₃): $\delta = 139.8, 139.0, 138.9, 138.7, 138.0, 137.9, 129.2, 128.9, 128.8, 128.7, 128.6, 128.5, 128.4, 128.2, 128.1, 127.96, 127.91, 127.7, 127.6, 126.5, 101.9, 101.7, 98.8$ (C-1'), 80.6, 79.3, 79.1, 78.6, 78.0, 77.6, 75.7, 75.4, 74.0, 73.9, 72.9, 70.0, 68.9, 68.7, 67.6, 55.7 (CH₃O).^[58] For β -anomer of disaccharide **21**, $R_f = 0.35$ (TLC developing solution: EtOAc/hexane = 1/4); ¹H NMR (300 MHz, CDCl₃): $\delta = 7.56-7.47$ (m, 5H), 7.45-7.28 (m, 10H), 5.63 (s, 1H; benzylidene-CH), 5.61 (d, $J = 5.0$ Hz, 1H), 4.97 (dd, $J = 32.7, 12.1$ Hz, 2H), 4.68-4.53 (m, 4H), 4.37 (dd, $J = 5.0, 2.5$ Hz, 1H), 4.32 (dd, $J = 10.4, 4.9$ Hz, 1H), 4.22 (ddd, $J = 13.4, 8.6, 2.2$ Hz, 3H), 4.14-4.08 (m, 1H), 4.07 (d, $J = 3.1$ Hz, 1H), 3.94 (t, $J = 10.3$ Hz, 1H), 3.67 (dd, $J = 10.7, 8.2$ Hz, 1H), 3.59 (dd, $J = 9.9, 3.1$ Hz, 1H), 3.41-3.29 (m, 1H), 1.53 (s, 3H; CH₃), 1.48 (s, 3H; CH₃), 1.36 (d, $J = 3.6$ Hz, 6H; CH₃); ¹³C NMR (75 MHz, CDCl₃): $\delta = 138.6, 138.5, 137.9, 129.3, 129.2, 128.7, 128.66, 128.61, 128.0, 127.9, 126.4, 110.0$ (C(CH₃)₂), 109.9 (C(CH₃)₂), 109.2 (C(CH₃)₂), 103.2 (C-1''), 101.8 (benzylidene-CH), 96.7 (C-1'), 78.8, 77.6, 75.5, 75.1, 72.5, 71.9, 71.1, 70.8, 70.4, 68.9, 68.3, 67.9, 26.4 (CH₃), 26.3 (CH₃), 25.4 (CH₃), 24.7 (CH₃).^[59]

Preparation of trisaccharide cores of *N*-linked glycan **22
with sequential glycosylation approach:**

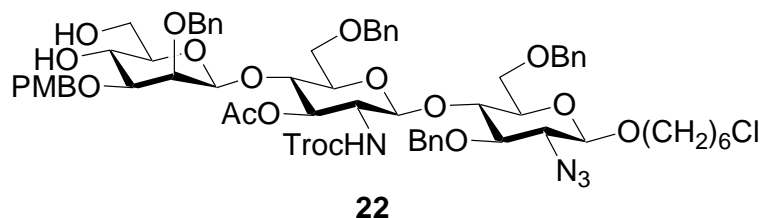

6-chlorohexyl 3,6-di-*O*-benzyl-2-azido-2-deoxy-4-*O*-[3-*O*-acetyl-6-*O*-benzyl-2-(trichloroethoxy carbonyl)-4-*O*-(2-*O*-benzyl-3-*O*-*p*-methoxybenzyl- β -D-mannopyranosyl)- β -D-glucopyranosyl]- β -D-glucopyranoside **22** was prepared according to procedure G and procedure H (90 mg, 40% over three steps from **2**), obtained as a colorless oil. For trisaccharide diol **22**, $R_f = 0.30$ (TLC developing solution: EtOAc/hexane = 1:1 + 1% MeOH); $[\alpha]_D^{27} = -45.9$ ($c = 0.20$, CHCl_3); $^1\text{H NMR}$ (300 MHz, CDCl_3): $\delta = 7.52\text{-}7.22$ (m, 17H), 6.94-6.82 (m, 2H), 5.02 (d, $J = 11.6$ Hz, 1H), 4.90-4.54 (m, 6H), 4.46-4.11 (m, 8H), 3.90 (ddd, $J = 19.8, 11.3, 6.9$ Hz, 4H), 3.81 (s, 3H; CH_3O), 3.78-3.59 (m, 4H), 3.56 (t, $J = 6.7$ Hz, 3H), 3.43-3.23 (m, 4H), 3.19 (dd, $J = 6.3, 3.0$ Hz, 1H), 3.07 (dd, $J = 9.4, 2.8$ Hz, 1H), 2.04 (s, 3H; $\text{CH}_3\text{C}=\text{O}$), 1.86-1.74 (m, 4H; CH_2), 1.72-1.59 (m, 2H; CH_2), 1.55-1.38 (m, 4H; CH_2); $^{13}\text{C NMR}$ (75 MHz, CDCl_3): $\delta = 171.0$ ($\text{C}=\text{O}$), 159.8 (COCH_3), 154.5 ($\text{OC}=\text{O}$), 139.1, 138.9, 138.0, 137.6, 129.9, 129.7, 129.6, 129.4, 129.3, 128.9, 128.7, 128.6,

128.55, 128.52, 128.3, 128.2, 128.1, 128.05, 128.00, 127.7, 114.3, 102.5 ($^1J_{\text{CH}} = 158.2$ Hz; C-1), 101.2 ($^1J_{\text{CH}} = 158.6$ Hz), 101.1 ($^1J_{\text{CH}} = 160.8$ Hz), 96.0 (CCl_3), 81.6, 81.4, 77.6, 76.4, 75.7, 75.5, 74.9, 74.8, 74.6, 74.5, 74.1, 74.0, 73.8, 73.0, 71.1, 70.4, 69.3, 67.6, 67.5, 66.5, 63.4, 56.7, 55.7, 45.4, 32.9, 29.7, 26.9, 25.6, 21.2; HRMS (Bio-ToFII): calcd for $\text{C}_{65}\text{H}_{79}\text{Cl}_4\text{N}_4\text{O}_{18}\text{Na}$ requires 1366.4041; found: $m/z = 1366.4036$ [$\text{M} + \text{Na}$] $^+$.

Rate dependent inverse-addition procedure for preparation of disaccharide **23**:

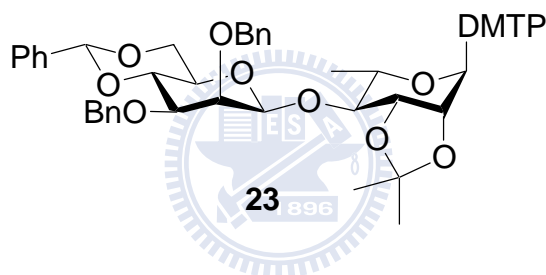

(2,6-dimethylphenyl) 2,3-*O*-isopropylidene-4-*O*-(2,3-di-*O*-benzyl-4,6-*O*-benzylidene- β -D-mannopyranosyl)-1-thio- α -L-rhamnopyranoside **23** was prepared according to procedure F (210 mg, 90%), obtained as a colorless oil. For compound **23**, $R_f = 0.35$ (TLC developing solution: EtOAc/hexane = 1:8; $[\alpha]_D^{27} = -140.4$ ($c = 0.77$, CHCl_3); ^1H NMR (300 MHz, CDCl_3): $\delta = 7.54$ (m, 4H), 7.47-7.29 (m, 12H), 7.24-7.11 (m, 2H), 5.67 (s, 1H; benzylidene-CH), 5.47 (s, 1H; H'-1), 5.06 (s, 1H, H-1), 4.95 (q, $J = 12.2$ Hz, 2H), 4.72 (q, $J = 12.6$ Hz, 2H), 4.44 (d, $J = 5.3$ Hz, 1H), 4.27 (ddd, $J = 15.4, 11.8, 5.3$ Hz, 3H), 4.10-3.94 (m, 3H), 3.73 (ddd, $J = 12.9, 9.9, 5.4$ Hz, 2H), 3.37 (dt, $J = 9.8, 4.9$ Hz, 1H), 2.60 (s, 6H; ArCH_3),

1.53 (s, 3H; CH₃), 1.40 (s, 3H; CH₃), 1.30 (d, *J* = 6.2 Hz, 3H; CH₃); ¹³C NMR (75 MHz, CDCl₃): δ = 143.4, 139.0, 138.8, 138.0, 131.9, 129.3, 129.2, 128.9, 128.8, 128.7, 128.6, 128.5, 128.3, 128.2, 128.1, 128.04, 128.00, 127.9, 126.4, 109.9 (C(CH₃)₂), 101.8 (benzylidene-CH), 100.4 (¹*J*_{CH} = 158.2 Hz; C-1''), 84.9 (¹*J*_{C-H} = 164.6 Hz; C-1'), 79.1, 78.5, 78.4, 78.2, 78.1, 76.8, 75.3, 72.6, 69.0, 68.1, 67.4, 28.2, 27.0, 22.6, 18.0; HRMS (Bio-ToFII): calcd for C₄₄H₅₀O₉SNa requires 777.3073; found: *m/z* = 777.3068 [M + Na]⁺.



第二部份 芳香族立體選擇醣質反應與其應用性

第四章 緒論

4.1 前言

4.1.1 α -L-岩藻醣與 α -L-岩藻醣苷水解酶之重要性簡介

α -L-岩藻醣苷水解酶現已經被歸納為醣類水解酵素第 29 家族之一 (CAZy Family GH-29)，其包括幾個重要的生物調控程序，^[25]如：人體發炎反應、血液傳輸、細胞代謝、癌症腫瘤的轉移及人類基因遺傳疾病。此類醣苷水解酵素為一外切型 (Exo-) 醣水解酵素，^[26]其廣泛分布於自然界中的各物種之中，如：細菌、黴菌、軟體動物及哺乳動物，^[27]其主要作用在催化生物體內含 L-岩藻醣基的聚醣、醣肽、醣蛋白質的水解及代謝。近幾年的研究亦已經證實， α -L-岩藻醣苷水解酶為一進行診斷肝臟癌細胞之重要血清。^[28]

α -L-岩藻醣為一去六氧半乳糖 (6-deoxy-L-galactose)，常被發現於以氮鍵結 (N-linked) 或氧鍵結 (O-linked) 所形成的醣類抗原 (Antigens of Golbo-H, KH-1) 上 (圖八)。^[29]經 α -1, 2、 α -1, 3、 α -1, 6 此特定立體位向鍵結於半乳糖 (Galactose) 或 N-乙醯葡萄糖胺 (N-acetyl glucosamine) 上。亦然研究此一 α -L-岩藻醣其生物體內之生理活性為本實驗室重要標的之一。

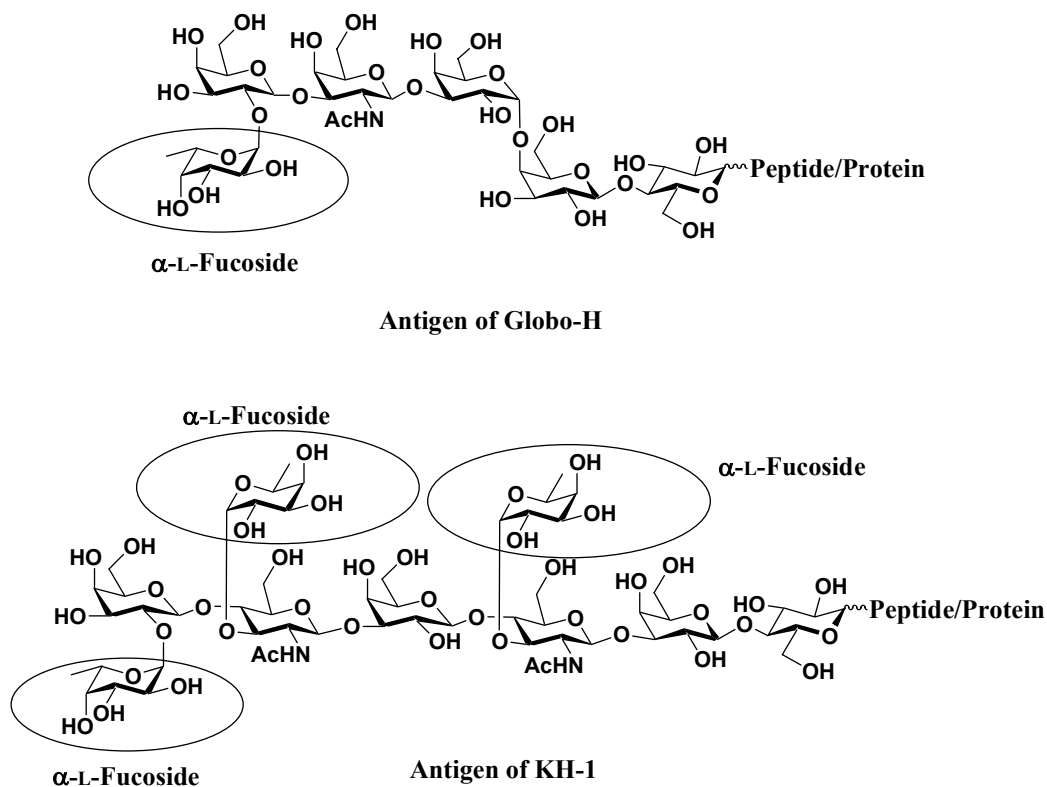

圖八、 Globo-H、KH-1 醣類抗原

4.2 研究動機

大部份的天然物中均含有醣類鍵結 (glycosidic linkages) 酚類 (phenols)，如：抗生素萬古黴素 (antibiotic vancomycin) 與抗糖尿病蛋白 (anti-diabetic phlorizin) 的分子結構。^[30] 酚類醣體配位 (phenyl aglycons) 被發現表現於一些重要的生物性機能上。^[31]

以有機化學合成法合成出發色體 (chromogenic) 氧-芳香類醣體 (*O*-aryl glycosides) 或螢光體醣配位基 (fluorogenic glycons) 之基質於酵素動力學研究上有相當大的價值性，^[32] 1879 年至今已經發表了許

多 *O*-Aryl glycoside 的合成方法: (1)鹼性條件下雙分子取代反應(SN₂ substitution under basic conditions)、^[33] (2)使用乙醃化(acetates)程序來進行 Helferich glycosylation、^[34] (3) Koenigs-Knorr 使用鹵素(halides)進行 glycosylation^[35] 與 (4) Mitsunobu reaction 使用 hemiacetals 與 phenol 進行氧化縮合反應(oxidation condensation)。^[36] 儘管這些已發表的合成法亦有應用性上的限制, 例如: 條件太激烈的 Helferich glycosylation 不適合 aryl glycosidic bonds 的形成、^[34] 在層析純化中易損失 aryl glycosidic bonds、為了增加產率而使用大量的 phenol。^[36]

本實驗室採用了 Schmidt 三氣乙醃氮絡化物醣合成方法, 由此合成法中改變 TMSOTf 莫耳量以增加 α -岩沼醣鍵結(流程二十三): (1) 使用 acetates 保護基的醣予體進行醣質反應, 以求縮短合成路徑、(2) 使用等莫耳量 TMSOTf 路易士酸以增加 α -岩沼醣鍵結醣基質產物、(3) 於低溫下與各類氮化芳香醇進行醣質化反應, 期望可得到 1,2-順式 α -L-岩藻醣基質為主要產物、(4) 將此合成法應用於 4-methylumbelliferyl aglycon (4-MU) 的合成上。^[37]

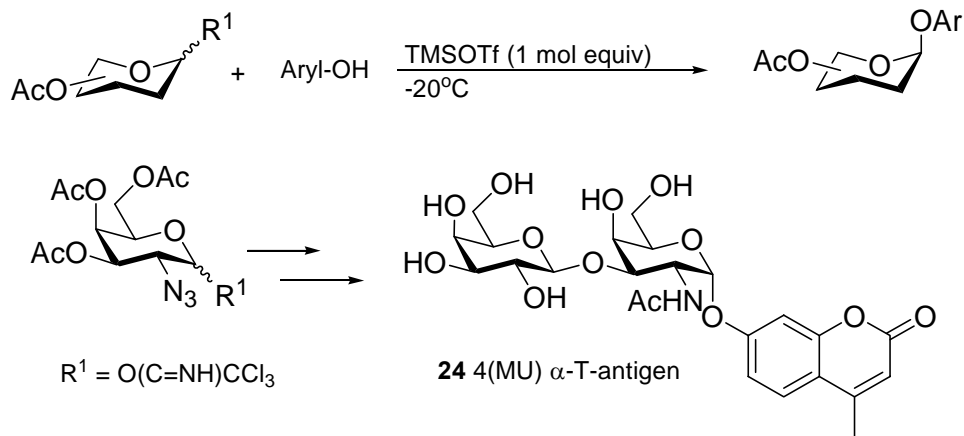

流程二十三、 α -L-岩藻糖基質之醣質化反應合成與應用

4.3 α -L-岩藻糖苷水解酶之水解反應催化機制簡介

1987年 White 等研究團隊已從人類肝臟 α -L-岩藻糖苷水解酶推測出其反應機制，^[38] α -L-岩藻糖苷水解酶是以結構保留機制(retention of anomeric configuration)此一機制來進行醣基質的催化水解。^[26]其水解酶具有兩氨基酸活性催化中心之酸基(general acid/base, catalytic nucleophile)，而以雙取代反應方式(double displacement)進行催化(流程二十四)。

首先 α -L-岩藻糖基質以其專一性結構與 α -L-岩藻糖苷水解酶結合，此時水解反應第一步驟在水解酶上的一般酸鹼活性催化基(general acid/base)由酸基對 α -L-岩藻糖基質上的離去基進行質子化(protonation)其被 α -L-岩藻糖基質為達穩定而進行離去，此同時 α -L-岩藻糖苷水解酶上另一催化親核基團(catalytic nucleophile)則對質子

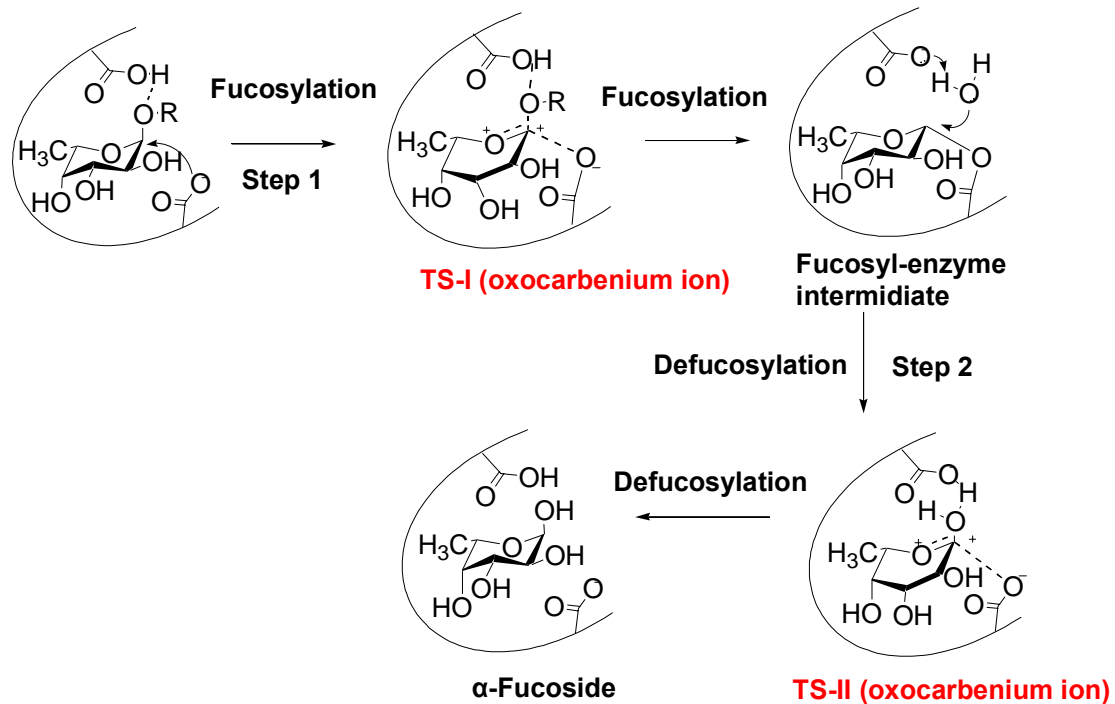

流程二十四、 α -L-岩藻糖苷水解酶反應機制



化離去基之鍵結位置進行反向位性親核反應 (inversion)，當水解酶上親核基以共價鍵與 α -L-岩藻糖基質鍵結時，為達穩定之 α -L-岩藻糖基質則同時離去而形成一反向性立體活性中心鍵結之 β -L-岩藻糖—水解酶中間體 (fucosyl-enzyme intermediate)；其中間體再由水解酶上的相對一般活性催化鹼基 (general base) 進行第二步驟去岩藻糖化反應 (defucosylation)，此一般活性鹼基則對水分子進行去質子化 (deprotonation) 使水分子轉變為一親核分子 OH^- ，進而攻擊中間體上糖基質立體活性中心碳原子以共價鍵結，形成與原 α -L-岩藻糖基質相同之結構保留糖基質 (retaining glycosubstrate)，而在此兩步驟之間糖基

質與醣水解酶會以帶正電含氧醣體離子(TS I/II, oxocarbenium ion) 此一過渡態存在。^[39]

4.4 α -L-岩藻醣及其醣基質之醣質化反應合成簡介

過去研究文獻中記載，^[40]在研究 α -L-岩藻醣苷水解酶之動力學上，大部份採用最佳活性 pH 值於 4.0–6.0 之間的 *p*-nitrophenyl- α -L-fucopyranoside 及 *p*-methylumbelliferyl- α -L-fucopyranoside 醣基質來進行醣水解酶動力活性上的研究。

而在 1956 年 Westphal 等研究團隊中，^[41]文獻中指出先將 α -L-岩藻醣上的 1、2、3、4 碳位上的-OH 基進行乙醴保護修飾 (acetyl protecting) 之後，再使用 $ZnCl_2$ 此類路易斯酸試劑於醋酸及醋酸苷混合溶劑中與 *p*-nitrophenol 以加熱 $125^\circ C$ 進行迴流反應，於 5 分鐘後可得到 *p*-nitrophenyl- α -L-fucopyranoside 等醣基質產物(流程二十五)。然而此一合成條件本實驗室經多次實驗結果無法得到再現性。

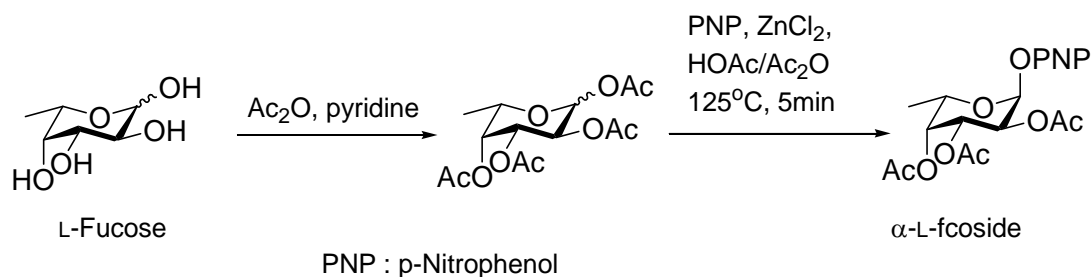

流程二十五、乙醴保護修飾 α -L-岩藻醣基質之醣質化反應

儘管在此一合成條件中無法得到 *p*-nitrophenyl- α -L-fucopyranoside 等醣基質產物，但此一簡單又快速的合成策略也啟發了我們；(1) 使用一容易處理且合成途徑較短的保護基修飾 L-岩藻醣。(2) 在進行離去保護基團反應後亦可保有欲得到的 α -立體位向醣基質產物。為本實驗室研究之首要目標。

在近幾年在 α -L-岩藻醣及其類似醣體的醣質化反應 (glycosylation) 合成方法研究中，其較常見合成方法中最具代表性的如；醣鹵化物予體 (glycosyl halides) 醣質化合成法，最早在 1879 年首先被使用在乙醯保護基的葡萄糖之醣質化反應上¹⁰ (流程二十六、二十七)。[42]

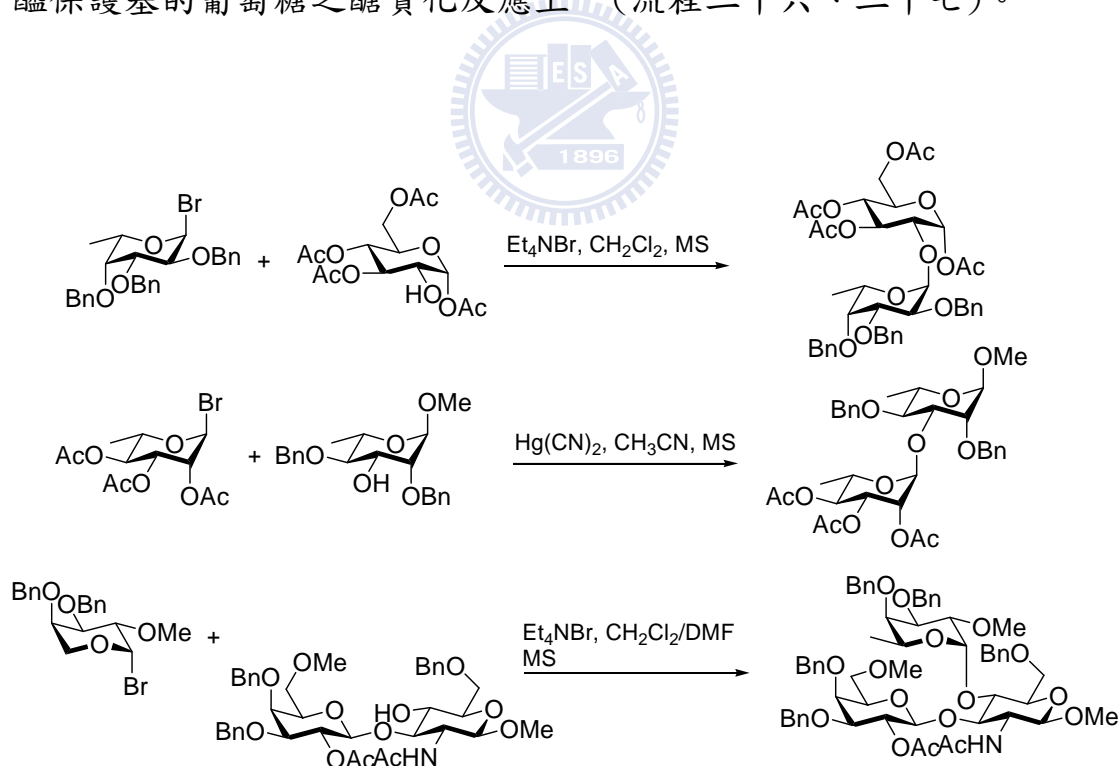

流程二十六、 α -L-岩藻醣及其醣基質之 Koenigs-Konrr 醣質化反應

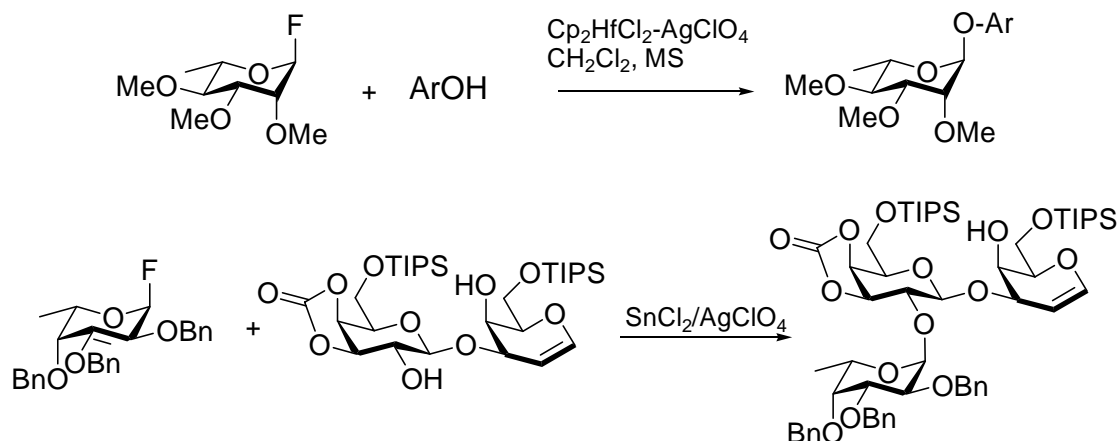

流程二十七、 α -L-岩藻糖及其糖基質之 Koenigs-Konrr 糖質化反應

而在 1901 年時由 Koenigs 及 Konrr 兩位化學家進一步改良應用在糖質化反應上，^[43]Koenigs-Konrr 反應主要是以糖鹵化物予體與糖受體 (glycosyl acceptors) 使用銀化合物此類路易士酸當作糖質化反應之前驅物 (promoter) 而進行糖質化反應。其反應機制可分為兩種程序；非均相程序 (heterogeneous process) 為一雙分子程序 (bimolecular process) 是以不溶銀化合物鹽類 (insoluble silver [I] salts) 對位於糖予體立體活性中心碳上的鹵化基進行固定立體位向鍵結，同時糖受體從反向攻擊 (inversion) 立體活性中心碳而得到 1,2-逆式 (1,2-*trans*) 糖體產物 (流程二十八)。

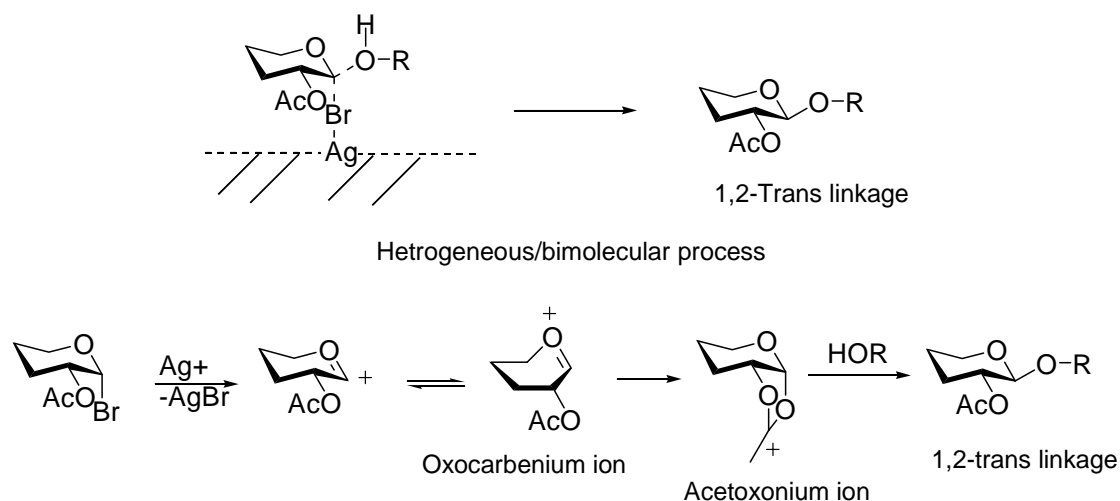

流程二十八、Koenigs-Konrr 反應之 1,2 逆式糖質化反應機

制

而均相程序(homogeneous process)為一單分子程序(unimolecular process)是以可溶銀(soluble silver [I])對位於糖予體立體活性中心碳上的鹵化基進行共價鍵結，當鹵化物離去後形成帶正電氧化糖體離子(oxocarbenium ion)中間體，糖予體 2-OAc 基氧原子上的成對電子在對帶正電氧化糖體離子中間體鍵結形成另一穩定態具有鄰基效應的脂化類糖中間體，糖受體再對立體活性中心碳反向攻擊而得到 1,2-逆式糖體產物。

1975 年 Lemieux 開發了鹵化醣予體催化(halide catalytic)之 1,2-順式鍵結醣質化反應合成產物(流程二十九)。^[44]經修飾成 2-OBn 溴化物醣予體(disarmed)，經由路易士酸前驅物活化醣予體上的溴化原子而形成溴化帶正電氧化醣體離子鹽類中間體(containing ion pair intermediated, CIP)，因醣予體 2-OBn 不具有鄰基效應，受活化溴化帶正電氧化醣體離子鹽類中間體，會先經過構型轉換成六環船型(6-Ring boat form)中間體，再與醣受體進行醣質化反應後，而得到 1,2-順式醣質化產物，Lemieux 所開發的鹵化醣予體催化 1,2-順式鍵結醣質化反應，直到今日已有 25 年之久，其普遍應用性非常高。

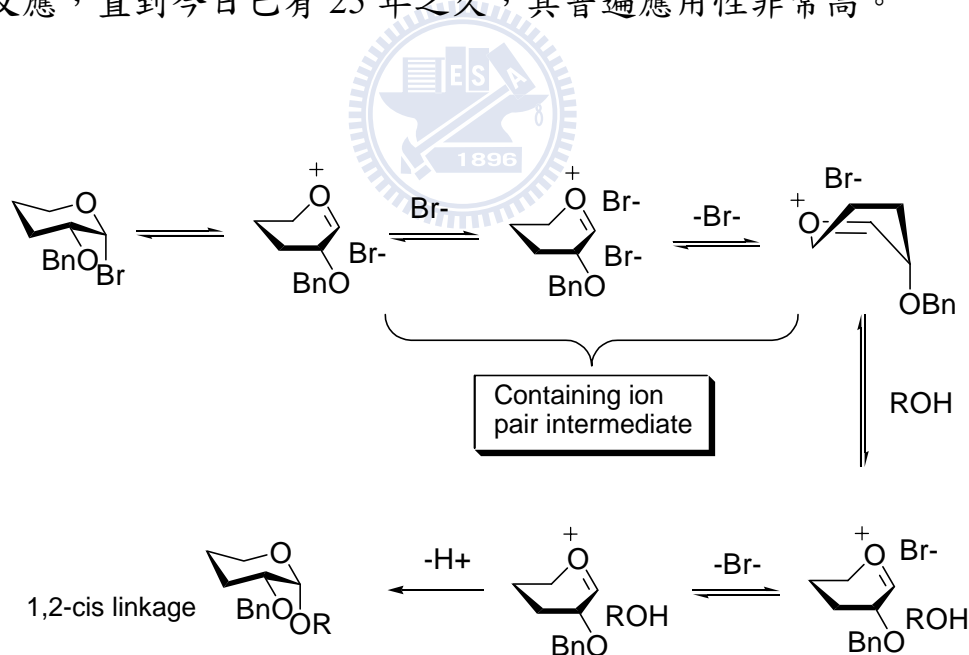

流程二十九、鹵化醣予體之 1,2-順式醣質化反應機制

在 1989 年 Keisuke 等研究團隊也以氟化類似岩藻糖予體與芳香醇化合糖受體使用高效率的 $\text{Cp}_2\text{HfCl}_2\text{-AgOCl}_4$ 前驅物進行糖質體糖質化反應合成 (流程二十七)。^[45] 由其實驗結果可瞭解；(1) 其類似岩藻糖於低溫下、(2) 使用高效率前驅物。此兩條件下可獲得 α -類似岩藻糖基質產物。

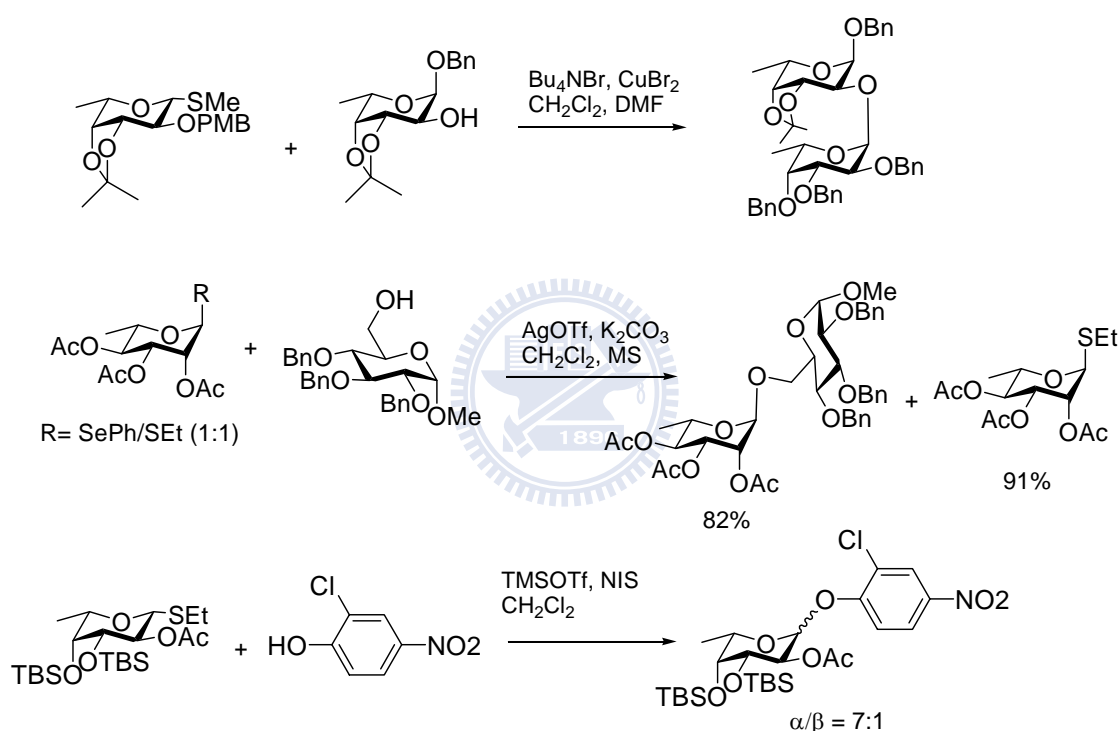

流程三十、 α -L-岩藻糖及其糖基質之硫化物糖予體糖質化反應

硫化物糖予體 (thioglycosyl donor) 合成方法,^[46] 也普遍應用在 α -L-岩藻糖及其類似糖體的糖質化反應上(流程三十)。其合成策略可分兩程序機制, 進而控制糖質產物上糖受體的 1,2-順式、1,2-逆式鍵

結(1,2-cis、1,2-trans linkages) 位向(流程三十一) 2-順式鍵結醣質化反應合成產物可經修飾成 2-OBn 硫化物醣予體 (armed), 再經由親電

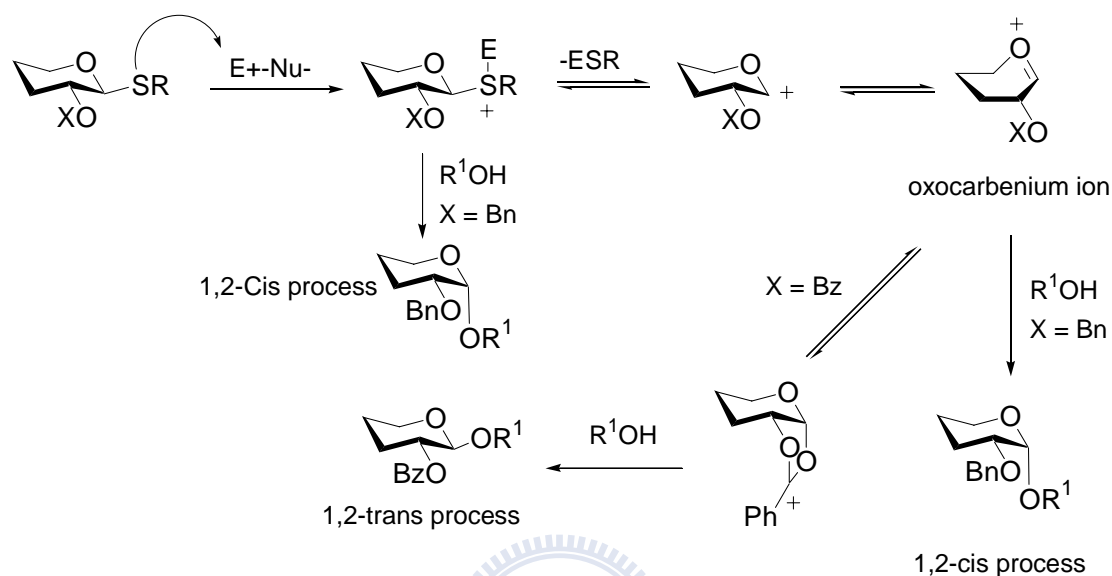

流程三十一、硫化物醣予體之醣質化反應機制

子基前驅物活化醣予體上的硫化原子進而離去形成帶正電氧化醣體離子中間體，因醣予體 2-OBn 不具有鄰基效應因此在受活化硫化物未脫離醣予體前，醣受體則在同時間進行反向攻擊醣予體活性立體中心碳的雙分子反應機制，而得到 1,2-順式醣質化產物。1,2-逆式鍵結醣質化反應合成產物可經修飾成 2-OBz 硫化物醣予體(Disarmed)，再經由親電子基前驅物活化醣予體上的硫化原子進而離去形成帶正電氧化醣體離子中間體，因醣予體 2-OBz 具有鄰基效應，因此在醣予體 2-OBz 基氧原子上的成對電子再對帶正電氧化醣體離子中間體鍵

結形成另一穩定態具有鄰基效應的脂化類糖中間體，糖受體再對立體活性中心碳反向攻擊而得到 1,2-逆式糖質化產物。

1977 年 Sinaý 為第一位將絡化物糖予體(Imidate donor)應用於糖質化合成反應上的德國化學家，^[47]而在 1986 年 Schmidt 這位德國化學家則將其方法改善(流程三十二)。^[48]其將糖體合成出三氯乙醯氮絡化物糖予體 (trichloroacetimidate donor)，另還應用於 Koenigs-Konrr 鹵化物糖予體合成上，而目前此合成方法通常也是以 armed、disarmed 進而控制 1,2-順式、逆式糖體產物，此方法使用不含重金屬試劑作糖質化反應前驅物，如； $\text{BF}_3 \cdot \text{Et}_2\text{O}$ 、TMSOTf 等此類較溫和路易斯酸試劑。

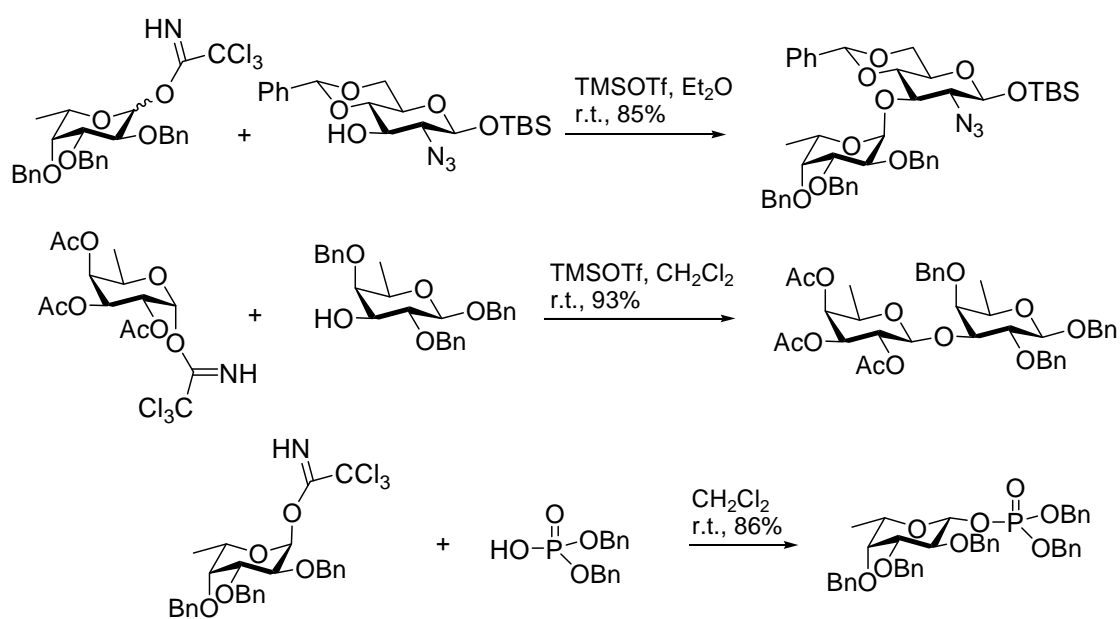

流程三十二、 α -L-岩藻糖之三氯乙醯氮絡化物糖予體糖質化反應

第五章 結果與討論

5.1 製備 α -L-岩藻糖基質醣質合成反應之探討

本實驗所採用醣質化合成法出自於 Schmidt 所發表過的三氯乙醯
氮絡化物醣予體合成法，^[48]將此法應用於 α -L-岩藻糖基質醣體的合成
上。將 L-岩藻糖經三個步驟合成修飾成的三氯乙醯氮絡化物醣予體
26 混合體後(流程三十三)，再與 *p*-nitrophenol 醣受體分別進行加入
0.05、0.5 與 1.0 莫耳量(mol equiv)TMSOTf 路易士酸前驅物於 -40°C 、
 -20°C 、 0°C 與 25°C 各種溫度條件下進行醣質合成反應，由(表十)實
驗結果得知等莫耳量 1.0 mol equiv TMSOTf 於 -20°C 溫度下可產生
 α -L-岩藻糖基質醣體唯一產物。

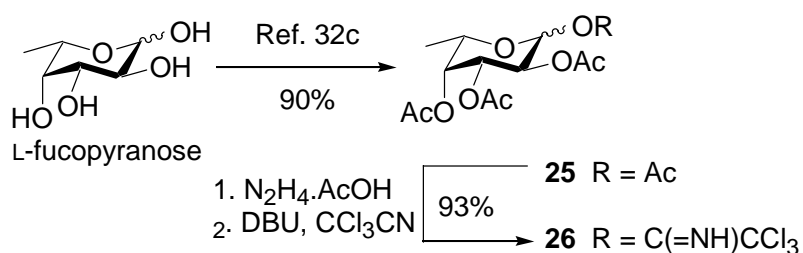

流程三十三、製備 per-O-acetyl L-fucopyranosyl imidate 26

表十、PNP 與 fucopyranosyl imidate 26 糖質合成反應條件

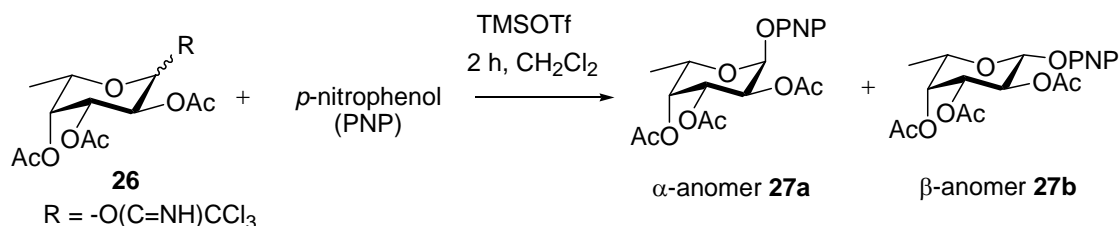

Entry	TMSOTf (mol equiv)	T(C)	27a ^a (%)	27b ^a (%)
1	0.05	-20	40	30
2	0.5	-20	22	30
3	1.0	-20	56	0
4	1.0	-40	54	0
5	1.0	0	26	26
6	1.0	25	22	22

a : Isolated yield.

我們亦針對一系列不同之芳香醇類糖受體使用等莫耳量 (1.0 mol equiv) TMSOTf 於 -20°C 件下進行糖質合成反應，生成以 1,2-順式 α -L-岩藻基質糖體產物 **38-44** (表十一)。但在 2,4-dinitrophenol、2-nitro-4-chlorophenol、2-nitrophenol 等具有 2-取代芳香醇化合物 (Aryl 2-substituent) 糖受體，卻無法在此條件下反應進一步獲得產物。我們推測解釋 2-取代芳香醇化合物，在酸性條件下芳香環上 1-醇取代官能基團，易與 2-硝酸取代 (2-Nitrophenol) 形成分子內氫鍵作用力 (intramolecular H-bonding) (圖九)，^[49] 而降低了本身親核能力，從實驗結果得知低溫條件下是完全無反應。

表十一、製備 L-fucopyranosides aryl-substrates

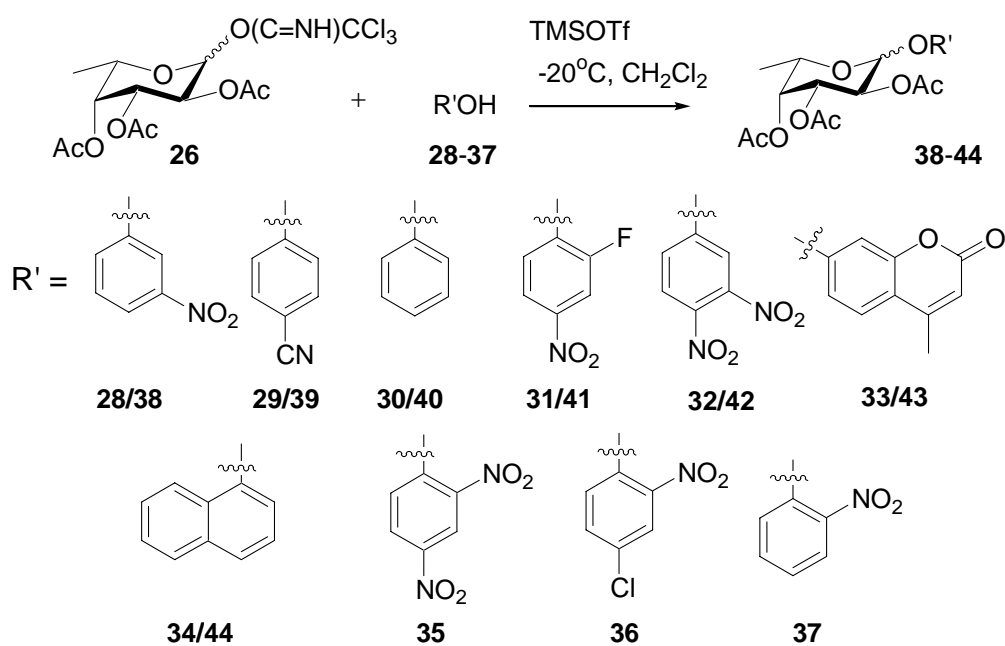

Entry	Acceptor (1.2 mol equiv)	Product ^a	Yield (%), α/β^b
1	28	38	53, α only
2	29	39	31, α only
3	30	40	75, α only
4	31	41	60, α only
5	32	42	35, α only
6	33	43	48, α only
7	34	44	82, 5/4
8	35	--	n.d.
9	36	--	n.d.
10	37	--	n.d.

a: Compound **26**, TMSOTf (1.0 mol equiv), 4Å MS, CH₂Cl₂, -20C, 0.5 to 2 h.

b: Isolated yield.

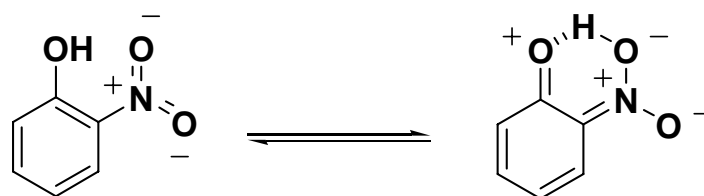

圖九、2-取代基芳香醇化合物分子間氫鍵作用力

5.2 PNP 與 per-*O*-acetyl glycosyl imidates 醣質合成反應

將修飾合成為乙醯保護基之葡萄糖(D-glucose)、葡萄糖胺(D-glucosamine)、半乳糖(D-galactose)、半乳糖胺(D-galactosamine)、甘露糖(D-mannose)與鼠李糖(L-rhamanose)等單醣製備成三氯乙醯氯絡化物醣予體後，以等莫耳量(1.0 mol equiv)TMSOTf於 -20°C 條件下進行醣質合成反應獲得醣體產物 **51-57**(表十二)。實驗結果發現醣予體 **45b**、**46b** 與 **47b** 進行醣質合成反應後可獲得 α -鍵結選擇性較佳的醣體主要產物，但是因為不穩定的 β -*O*-trichloroaceteimide離去基使得醣質合成反應產率極低。醣予體 **45**、**46** 與 **47** 進行醣質合成反應後則獲得 α -鍵結選擇性較佳與較高產率的醣體產物，而醣予體 **48**、**49** 與 **50** 進行醣質合成反應後獲得 α -鍵結醣體與高產率唯一產物。

表十二、 PNP 與 Per-*O*-acetyl glycosyl imidates 醣質合成反應

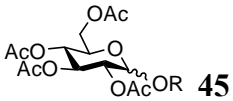
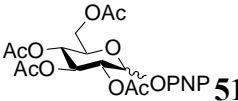
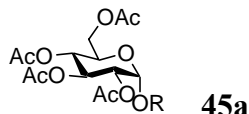
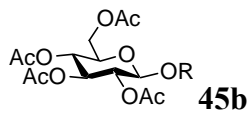
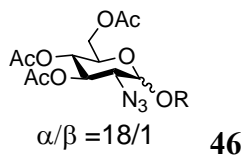
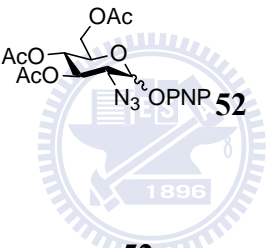
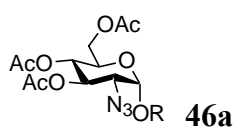
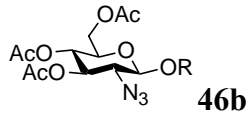
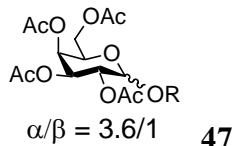
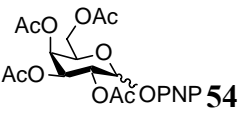
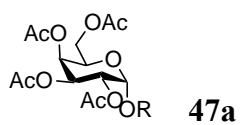
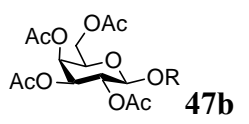
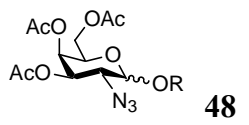
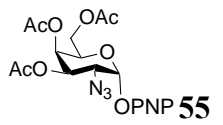
Entry	Glycosyl imidate R = -O(C=NH)CCl ₃	Product ^a	Yield (%), α/β^b	ref
1	 45	 51	52, 3.4/1	63, 64
2	 45a	51	50, 3.4/1	
3	 45b	51	20, 3.8/1	
4	 46 $\alpha/\beta = 18/1$	 52	49, 4.5/1	
5	 46a	52	50, 4.8/1	
6	 46b	52	15, 4.5/1	
7	 47 $\alpha/\beta = 3.6/1$	 54	60, 5.4/1	64
8	 47a	54	62, 5.0/1	
9	 47b	54	30, 5.6/1	
10	 48	 55	60, α only	

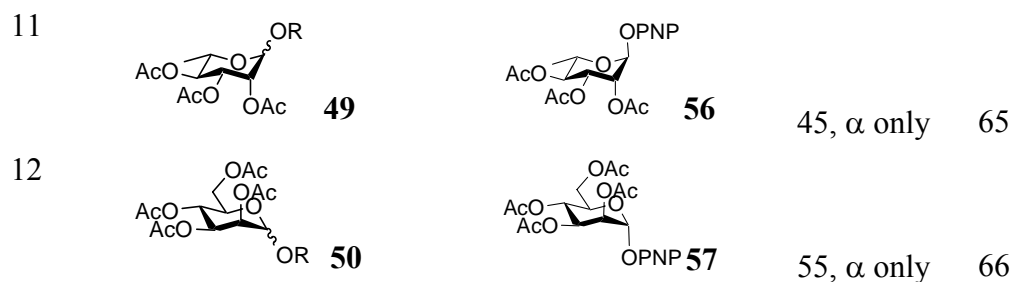

a: PNP(1.2 mol equiv), TMSOTf (1.0 mol equiv), CH₂Cl₂, 4 Å-MS, -20°C, 0.5 to 2 h.
 b: α : β Anomeric ratio was determined by HPLC analysis of crude anomeric mixture (Elution with 7:3 Hexane:EtOAc at 1.2 mL/min over Mightysil Si 60 250–4.6). c: Anomeric mixture **52** was deacetylated to give α -anomer **53** for NMR characterization.

5.3 4-MU α -T-antigen 之醣質合成反應與應用

製備合成出 4-MU α -T-antigen 加以驗證了我們所開發出的合成條件對 α -aryl glycosidic linkages 的應用性。近期 Kiso 發表文獻中也提及，^[36d]運用 Mitsunobu condensation 合成法將大量的 4-MU 與 4,6-*O*-di-(*t*-butylsilylidene)保護官能機的雙醣予體進行反應而獲得低產率與 α / β = 9/1 的雙醣體產物。

本實驗室運用等莫耳量(1.0 mol equiv) TMSOTf 將 4-MU **33** 與醣予體 **48** 於 -20°C 下進行醣質合成反應(流程三十四)，獲得 70% α -anomer of aryl glycoside **58** 單一產物，在過去發表文獻中 Lemieux 亦合成出產率 33% 與 α / β = 9/1 的醣體 **48** 化合物，NMR 光譜實驗 (α -anomer of **58**: ¹H, δ = 5.70, ³J_{1,2} = 3.6 Hz; ¹³C, δ = 97.4; β -anomer of **58**: H, δ = 5.02, ³J_{1,2} = 7.8 Hz; ¹³C, δ = 100.5) 亦驗證了結果。^[35a]

再進行去乙酰化反應 (deacetylation) 與 benzylidenation 反應後獲得單糖體 **59**，再與糖予體 **47** 使用催化量 (0.1 mol equiv) TMSOTf 於 -20°C 下進行糖質合成反應，獲得產率 75% 的 β -anomer of 4-MU T-antigen **60** 唯一雙糖體產物，再經過四個去保護基標準反應程序後獲得產率 40% 的 4-MU α -T-antigen **24**，本實驗合成法與過去已知合成條件相比較：(1) 縮短合成路徑，達到標的物所需時間減少、(2) 提高了 α -anomer of aryl glycoside 選擇性糖體產物、(3) 增加了最終糖體產物產率。

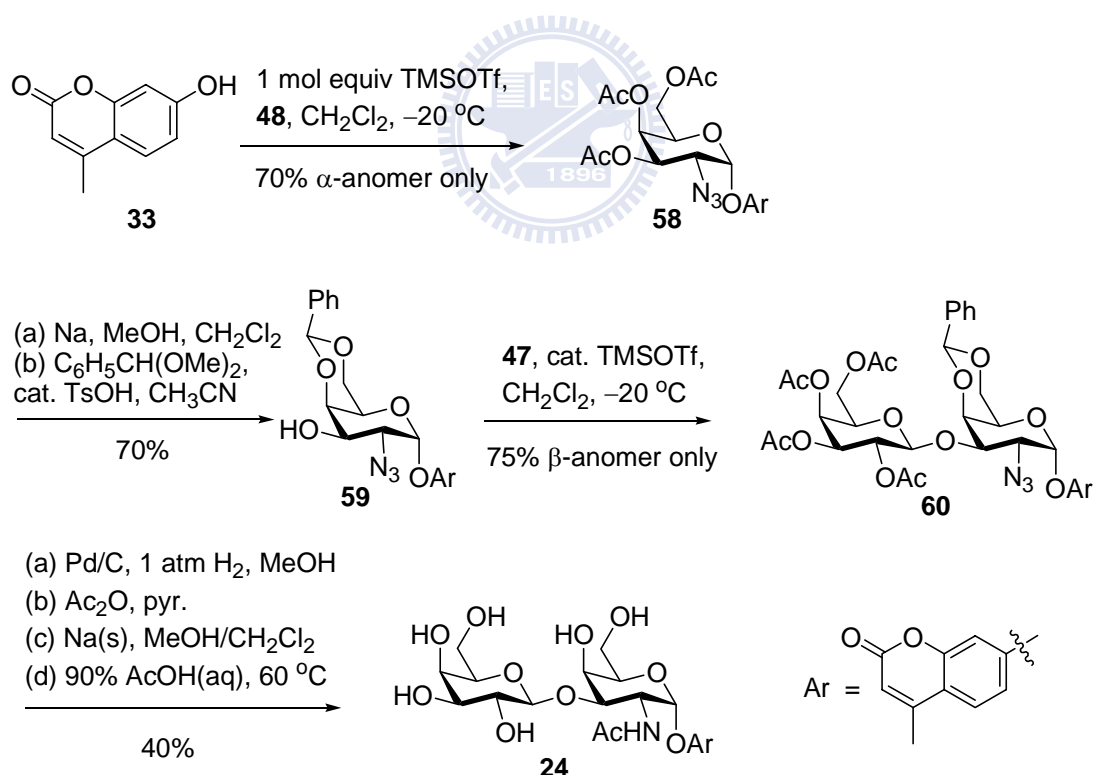

流程三十四、4-MU α -T-antigen 之糖質合成反應

5.4 反應機構推論

根據實驗結果我們推論 α -anomeric glycosylation(流程三十五)可能進行的醣質反應機構，在使用等莫耳量 (molar equiv) TMSOTf 活化 glycosyl imidate 醣予體形成 oxocarbenium ion 後，再與 triflate counter ion 形成 oxocarbenium triflate ion pair 中間體。若受到 C2-acetyl function 鄰基效應(neighboring-group participation)影響則 oxocarbenium 中間體進行平衡形成 acetoxonium ion 中間體，當 acetoxonium ion 中間體受到醣受體親核攻擊後則獲得 β -glycoside。然而親核力較弱的酚類(phenol)特別是在苯環上具拉電子基(electron-withdrawing group)的酚類親核能力更弱，其親核反應發生在 oxocarbenium triflate ion pair 中間體而形成 α -與 β -glycosyl oxonium 中間體混合物，當受到 anomeric effect 影響時形成 α -glycosyl oxonium 則更穩定於形成 β -glycosyl oxonium。另外，由醣予體 **26**、**47**、**48** 與醣予體 **45**、**46** 相互比較實驗結果，在進行醣質合成反應後醣予體 **26**、**47**、**48** 獲得高 α -selectivity，axially C-4 acetyl function 與 ring oxygen atom 具有 through-space electrostatic interaction 而提升更大穩定於 α -glycosyl oxonium。

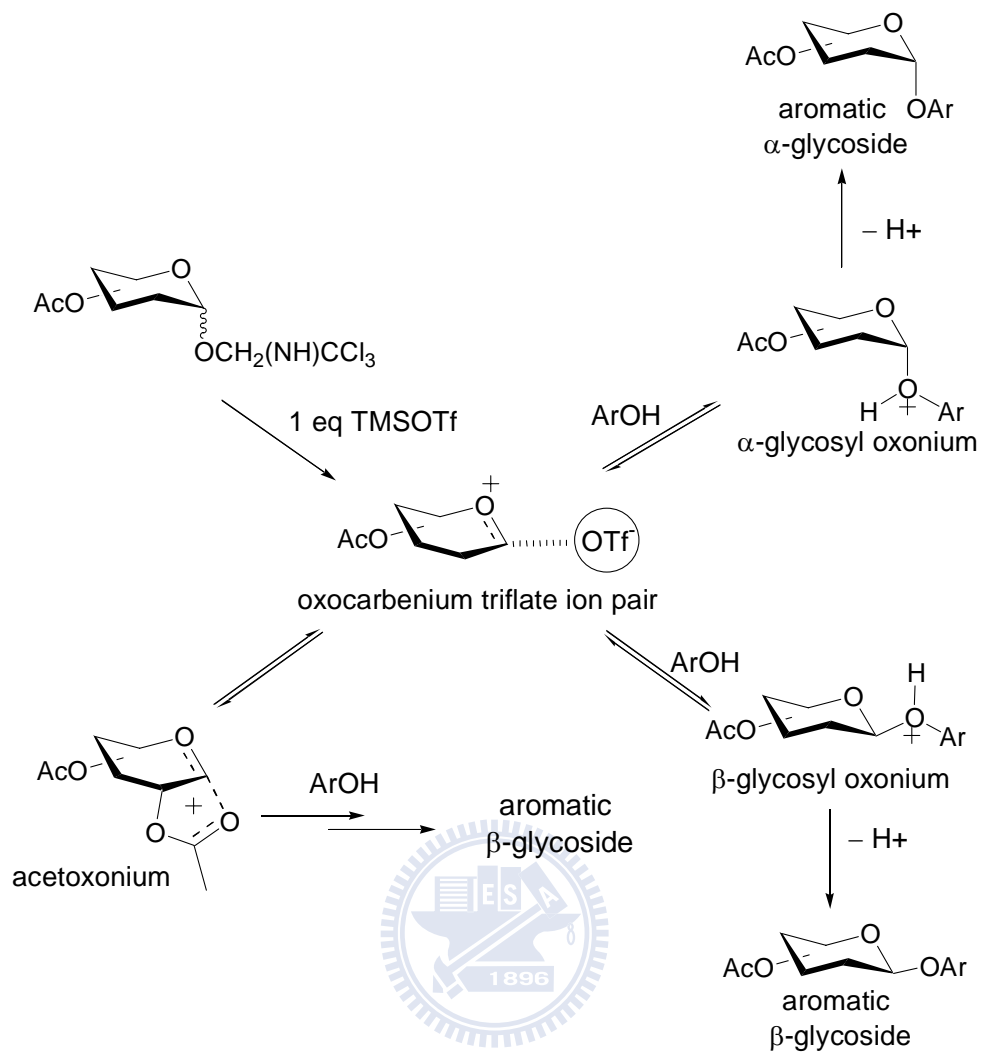

流程三十五、 α -selective aromatic 糖質合成反應機構推論

5.4 結論

1. 使用乙醯基所修飾的三氯乙醯氯絡化物醣予體合成法，因為標的物合成路徑縮短，可快速製備而減少損失價值昂貴的 L-岩藻糖。
2. 使用等莫耳量(molar equiv) TMSOTf 於低溫下進行醣質合成反應，合成出一系列的 α -aryl glycoside 醣體基質，在生物酵素動力學研究上其合成價值不容忽略。
3. 實驗結果得知將各種單醣予體使用等莫耳量(molar equiv)TMSOTf 於低溫下進行醣質合成反應， β -醣予體進行醣質反應後產生 α -selectivity 最佳但產率極低，而在 axially C4 acetyl function 與 ring oxygen 的 through-space electrostatic interaction 影響下也產生高 α -selectivity 的醣體主要產物。
4. 成功運用等莫耳量(molar equiv)TMSOTf 醣質反應合成法，製備出 cancer-related fluorogenic 4-MU α -T-antigen **24**，與過去已知條件相比較:獲得 α -selectivity 唯一醣體產物、縮短標的物合成所需路徑、提高標的物產率、合成所需藥劑較經濟，亦加以驗證了等莫耳量(molar equiv) TMSOTf 醣質反應合成法於 O-aryl α -glycopyranosides 的應用性。

第六章 實驗部份

6.1 Experimental

6.1.1 General experimental

Chemicals used in experiments were purchased as ACS reagent grade and used without further purification. Hexane and EtOAc for HPLC elution were purchased as HPLC reagent grade and degassed by ultrasonication before use. Molecular sieve MS-4A was activated by microwave irradiation and flame dried intermediately before use. ACS reagent grade CH_2Cl_2 were distilled over calcium hydride under N_2 . Amberlite IR-120 H^+ was washed sequentially with deionized H_2O and MeOH, followed by drying under *vacuo* for 18 h before use. Normal phase and reverse phase flash column chromatography were performed on silica gel 60 (70–230 mesh) and 75 μM RP-C18 silica gel respectively. ^1H and ^{13}C NMR spectra of the prepared compounds were recorded with either Bruker 300 MHz and 75 MHz or with Inova 500 MHz and 125 MHz spectroscopies. Chemical shift (δ ppm) was measured against TMS, generated from the residual CHCl_3 lock signal at δ 7.26 ppm against the residual proton signal of deuterated chloroform and the ^{13}C resonance signal is calibrated against the ^{13}C signal of deuterated chloroform. HPLC analysis was performed with gradient pump of Hitachi L-2130 and UV-detector L-2400.

6.1.2 General procedure

Procedure A:

To a solution of 2,3,4-*O*-triacetyl L-fucopyranosyl trichloroacetimidate **3**^[60] (100 mg, 0.23 mmol) in CH₂Cl₂ (2.0 mL), *p*-nitrophenol (PNP) or phenol **28-37** (1.2 mol equiv) and MS-4A (300 mg) were added. Upon further addition of TMSOTf (40 μL, 0.23 mmol), the mixture was stirred at -20 °C under N₂. Complete glycosylation was assessed by TLC and the reacting mixture was diluted with CH₂Cl₂ (10 mL). After filtration removal of MS-4A, the CH₂Cl₂ solution was washed with sat. NaHCO₃ (20 mL × 2), water (20 mL × 1), brine (20 mL × 1), dried over MgSO₄, filtered and concentrated for column chromatography over silica gel to furnish 2,3,4-*O*-triacetyl L-fucopyranoside substrates **27** and **38-44**.

Procedure B.

To a solution of per-*O*-acetyl glycopyranosyl trichloroacetimidate **45-50**^[61] (100 mg, 1.0 mol equiv) in CH₂Cl₂ (2.0 mL), *p*-nitrophenol (PNP) (1.2 mol equiv) and MS-4A (300 mg) were added at -20 °C. Upon addition of TMSOTf (1.0 mol equiv), the mixture was stirred at -20 °C under N₂ for 0.5-2 h and progress of reaction was monitored by TLC. Upon complete glycosylation, CH₂Cl₂ (10 mL) was added to the mixture, and the organic phase was washed with sat. NaHCO₃ (20 mL × 2), water (20 mL × 1), brine (20 mL × 1), dried over MgSO₄, filtered, and concentrated for column chromatography purification over silica gel.

Elution with EtOAc/hexane mixture afforded the respective α - and β -anomers of the titled *p*-nitrophenyl per-*O*-acetyl glycopyranosides **51**, **54–57**. Crude anomer mixture of glycoside **52** (50 mg, 0.11 mmol) was dissolved in MeOH (2.0 mL) at 0 °C, which was followed by the addition of a piece of freshly cut sodium (ca 20 mg). The mixture was stirred from 0 °C to rt for 2 h and then neutralized with IR-120 H⁺. After filtration removal of resin and removal of solvent by rotary evaporator, the crude deacetylated product was purified by column chromatography over silica gel with 1:20 v/v MeOH/CH₂Cl₂ elution to give α -anomer **53** as white amorphous solid (29.0 mg, 80%).

6.2 Phenyl 2,3,4-*O*-triacetyl-L-fucopyranoside **27**, **38–44**

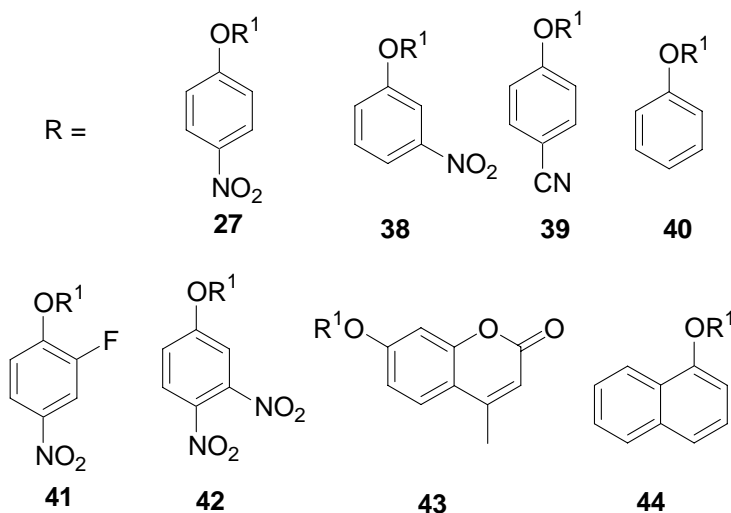
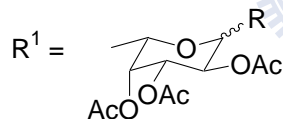

(*p*-Nitrophenyl) 2,3,4-tri-*O*-acetyl- α -L-fucopyranoside **27a** was prepared according to procedure A was obtained as white glassy solid. For compound **27a** (53.0 mg, 56%): ^1H NMR (300 MHz, CDCl_3): δ = 8.22–8.19 (m, 2H), 7.17–7.13 (m, 2H), 5.86 (d, J = 4.0 Hz, 1H), 5.58 (dd, J = 6.0, 12.0 Hz, 1H), 5.37 (ddd, J = 6.0, 6.0, 12.0 Hz, 2H), 4.29 (q, J = 7.0, 14.0 Hz, 1H), 2.19 (s, 3H), 2.05 (s, 3H), 2.01 (s, 3H), 1.21 (d, J = 7.0 Hz, 3H); ^{13}C NMR (75 MHz, CDCl_3): δ = 170.67, 170.65, 170.3, 161.3, 143.0, 126.1, 116.5, 94.9, 70.7, 67.8, 67.6, 66.3, 20.9, 20.9, 20.8, 16.0; HRMS–FAB: calcd for $\text{C}_{18}\text{H}_{21}\text{NO}_{10}$ requires 412.1244; found m/z = 412.1245 $[\text{M} + \text{H}]^+$.

(*m*-Nitrophenyl) 2,3,4-tri-*O*-acetyl- α -L-fucopyranoside **38** was prepared according to procedure A was obtained as colorless oil. For compound **38** (50.0 mg, 53%): ^1H NMR (300 MHz, CDCl_3): δ = 7.95–7.90 (m, 2H), 7.52–7.44 (m, 1H), 7.42–7.36 (m, 1H), 5.83 (d, J = 3.6 Hz, 1H), 5.57 (dd, J = 10.9, 3.3 Hz, 1H), 5.40–5.35 (m, 1H), 5.34–5.27 (m, 1H), 4.23 (q, J = 6.3 Hz, 1H), 2.21 (s, 3H), 2.08 (s, 3H), 2.04 (s, 3H), 1.14 (d, J = 6.5 Hz, 3H); ^{13}C NMR (75 MHz, CDCl_3): δ = 170.5, 170.4, 170.1, 156.9, 149.5, 130.3, 122.7, 117.6, 114.6, 111.6, 95.2, 70.7, 67.7, 67.6, 66.0, 20.8, 20.7, 20.6, 15.9; HRMS–FAB: calcd for $\text{C}_{18}\text{H}_{21}\text{NO}_{10}$ requires 412.1244; found m/z = 412.1246 $[\text{M} + \text{H}]^+$.

(*p*-Cyanophenyl) 2,3,4-tri-*O*-acetyl- α -L-fucopyranoside **39** was prepared according to procedure A was obtained as colorless oil. For compound **39** (28.0 mg, 31%): ^1H NMR (300 MHz, CDCl_3): δ = 7.63–7.59 (m, 2H), 7.16–7.11 (m, 3H), 5.81 (d, J = 3.6 Hz, 1H), 5.57 (dd, J = 3.3, 11.1 Hz, 1H), 5.36 (d, J = 3.3 Hz, 1H), 5.31 (dd, J = 3.3, 11.1 Hz, 1H), 4.21 (q, J = 6.0, 12.9 Hz, 1H), 2.18 (s, 3H), 2.01 (s, 3H), 1.98 (s, 3H), 1.17 (d, J = 6.0 Hz, 3H); ^{13}C NMR (75 MHz, CDCl_3): δ = 170.5, 170.4, 170.1, 159.6, 134.1, 117.0, 106.1, 94.6, 70.6, 67.7, 67.5, 66.0, 20.8, 20.74, 20.6, 15.9; HRMS–FAB: calcd for $\text{C}_{18}\text{H}_{22}\text{NO}_8$ requires 392.1345; found m/z = 392.1335 $[\text{M} + \text{H}]^+$.

(Phenyl) 2,3,4-tri-*O*-acetyl- α -L-fucopyranoside **40** was prepared according to procedure A was obtained as white glassy solid. For compound **40** (63.0 mg, 75%): ^1H NMR (300 MHz, CDCl_3): δ = 7.33–7.21 (m, 2H), 7.07–7.02 (m, 3H), 5.74 (d, J = 3.6 Hz, 1H), 5.61 (dd, J = 3.6, 11.1 Hz, 1H), 5.37 (d, J = 3.3 Hz, 1H), 5.30 (dd, J = 3.6, 11.1 Hz, 1H), 4.31 (q, J = 5.4, 12.6 Hz, 1H), 2.20 (s, 3H), 2.07 (s, 3H), 2.01 (s, 3H), 1.25 (d, J = 6.6 Hz, 3H); ^{13}C NMR (75 MHz, CDCl_3): δ = 170.6, 170.5, 170.2, 156.6, 129.6, 122.7, 116.5, 94.8, 71.0, 68.0, 67.9, 65.4, 20.8, 20.7, 20.7, 15.9; HRMS–FAB: calcd for $\text{C}_{18}\text{H}_{23}\text{NO}_8$ requires 367.1393; found m/z = 367.1393 $[\text{M} + \text{H}]^+$.

(2-Fluoro-4-nitrophenyl) 2,3,4-tri-*O*-acetyl- α -L-fucopyranoside **41** was prepared according to procedure A was obtained as colorless oil. For compound **41** (59.0 mg, 60%): ^1H NMR (300 MHz, CDCl_3): δ = 8.08–8.02 (m, 2H), 7.34–7.28 (m, 1H), 5.89 (d, J = 3.6 Hz, 1H), 5.60 (dd, J = 3.6, 10.8 Hz, 1H), 5.42 (d, J = 2.4 Hz, 1H), 5.33 (dd, J = 3.6, 10.8 Hz, 1H) 4.33 (q, J = 6.3, 12.6 Hz, 1H), 2.21 (s, 3H), 2.08 (s, 3H), 2.03 (s, 3H), 1.18 (d, J = 6.6 Hz, 3H); ^{13}C NMR (75 MHz, CDCl_3): δ = 171.0, 170.7, 170.3, 150.4, 150.2, 121.1, 117.6, 113.4, 113.1, 96.7, 70.8, 67.9, 67.8, 66.8, 21.1, 21.09, 21.00, 16.2; HRMS–FAB: calcd for $\text{C}_{18}\text{H}_{20}\text{FNO}_{10}$ requires 429.1071; found m/z = 429.1075 $[\text{M} + \text{H}]^+$.

(3,4-Dinitrophenyl) 2,3,4-tri-*O*-acetyl- α -L-fucopyranoside **42** was prepared according to procedure A was obtained as colorless oil. For compound **42** (37.0 mg, 35%): ^1H NMR (300 MHz, CDCl_3): δ = 8.05 (d, 1H), 7.47 (d, 1H), 7.37 (dd, 1H), 5.88 (d, J = 3.6 Hz, 1H, H-1), 5.54 (dd, J = 3.6, 11.1 Hz, 1H), 5.37–5.29 (m, 2H), 4.15 (q, J = 6.6, 11.1 Hz, 1H), 2.20 (s, 3H), 2.07 (s, 3H), 2.04 (s, 3H), 1.16 (d, J = 6.6 Hz, 3H); ^{13}C NMR (75 MHz, CDCl_3): δ = 170.7, 170.5, 170.4, 160.3, 145.6, 137.0, 119.4, 113.1, 95.9, 70.6, 67.7, 67.5, 67.2, 21.1, 21.0, 20.9, 16.2; HRMS–TOF: calcd for $\text{C}_{18}\text{H}_{20}\text{N}_2\text{O}_{12}\text{Na}$ requires 479.0914; found m/z = 479.0920 $[\text{M} + \text{Na}]^+$.

(4-Methylumbelliferyl) 2,3,4-tri-*O*-acetyl- α -L-fucopyranoside **43** was prepared according to procedure A was obtained as white glassy

solid. For compound **43** (50.0 mg, 48%): ^1H NMR (300 MHz, CDCl_3): δ = 7.55 (d, 1H), 7.06–6.99 (m, 2H), 6.19 (d, 1H), 5.81 (d, J = 3.6 Hz, 1H), 5.59 (dd, J = 3.6, 11.1 Hz, 1H), 5.37 (d, J = 5.4 Hz, 1H), 5.32 (dd, J = 3.6, 10.8 Hz, 1H), 4.22 (q, J = 7.0, 13.2 Hz, 1H), 2.41 (s, 3H), 2.20 (s, 3H), 2.10 (s, 3H), 2.03 (s, 3H), 1.14 (d, J = 6.3 Hz, 3H); ^{13}C NMR (75 MHz, CDCl_3): δ = 170.5, 170.4, 170.1, 161.0, 159.2, 155.0, 152.2, 125.8, 115.2, 113.4, 113.0, 104.3, 95.0, 70.7, 67.8, 67.6, 65.9, 20.79, 20.76, 20.6, 18.7, 15.9; HRMS–TOF: calcd for $\text{C}_{18}\text{H}_{21}\text{NO}_{10}$ requires 449.1448; found m/z = 449.1438 $[\text{M} + \text{H}]^+$.

(2-Naphthyl) 2,3,4-tri-*O*-acetyl-L-fucopyranoside **44** was prepared according to procedure A was obtained as white glassy solid (50.0 mg, 82%, α/β = 5/4). For α -anomer fucopyranoside **44**: ^1H NMR (300 MHz, CDCl_3): δ = 7.81–7.75 (m, 3H), 7.45–7.36 (m, 3H), 7.23–7.19 (m, 1H), 5.58 (dd, J = 8.1, 10.5 Hz, 1H), 5.35 (d, J = 3.3 Hz, 1H), 5.21–5.14 (m, 2H), 4.06 (q, J = 6.3, 12.6 Hz, 1H), 2.23 (s, 3H), 2.08 (s, 3H), 2.04 (s, 3H), 1.33 (d, J = 6.3 Hz, 3H); ^{13}C NMR (75 MHz, CDCl_3): δ = 171.1, 170.6, 169.9, 155.3, 134.9, 131.0, 130.0, 128.1, 127.5, 126.9, 125.0, 119.2, 111.6, 100.0, 71.6, 70.4, 69.9, 68.7, 21.2, 21.1, 21.0, 16.6; HRMS–EI: calcd for $\text{C}_{22}\text{H}_{24}\text{O}_8$ requires 416.1471; found m/z = 416.1467 $[\text{M}]^+$.

6.3 *p*-Nitrophenyl per-*O*-acetyl-glycopyranosides **51**, **54–57**

(*p*-Nitrophenyl) 2,3,4,6-tetra-*O*-acetyl- α -L-glucopyranoside **51a** was prepared according to procedure B was obtained as colorless oil. For compound **51a** (36.0 mg, 38%): ^1H NMR (300 MHz, CDCl_3): δ = 8.24–8.20 (m, 2H), 7.22–7.19 (m, 2H), 5.85 (d, J = 3.6 Hz, 1H), 5.72 (t, J = 9.9 Hz, 1H), 5.20 (t, J = 10.2 Hz, 1H), 5.09 (dd, J = 3.6, 10.2 Hz, 1H), 4.26 (dd, J = 4.5, 12.3 Hz, 1H), 4.05–4.00 (m, 2H), 2.07 (s, 3H), 2.06 (s, 3H), 2.04 (s, 3H), 2.03 (s, 3H); ^{13}C NMR (75 MHz, CDCl_3): δ = 170.3, 170.07, 170.03, 169.4, 143.0, 125.7, 116.4, 94.0, 69.9, 69.5, 68.5, 67.8, 61.2, 20.58, 20.54, 20.50, 20.4; HRMS–ES: calcd for $\text{C}_{20}\text{H}_{23}\text{NO}_{12}$ requires 470.1299; found m/z = 470.1308 [$\text{M} + \text{H}$] $^+$.

(*p*-Nitrophenyl) 2,3,4,6-tetra-*O*-acetyl- β -L-glucopyranoside **51b** was prepared according to procedure B was obtained as colorless oil. For compound **51b** (12.0 mg, 13%): ^1H NMR (300 MHz, CDCl_3): δ = 8.24–8.19 (m, 2H), 7.26–7.04 (m, 2H), 5.47–5.07 (m, 3H), 4.31–3.90 (m, 4H), 2.09 (s, 3H), 2.07 (s, 3H), 2.06 (s, 3H), 2.01 (s, 3H); ^{13}C NMR (75 MHz, CDCl_3): δ = 170.3, 170.1, 169.3, 169.1, 143.2, 125.7, 116.5, 97.9, 72.4, 72.3, 70.8, 67.9, 61.7, 20.6, 20.59, 20.55, 20.52.

(*p*-Nitrophenyl) 2-azido-2-deoxy- α -D-glucopyranoside **53** was prepared according to procedure B was obtained as colorless oil. For compound **53** (29.0 mg, 80%): ^1H NMR (300 MHz, CDCl_3): δ = 8.24 (dd,

2H), 7.31 (dd, 2H), 5.76 (d, $J = 3.6$ Hz, 1H), 4.05 (dd, $J = 8.4, 10.2$ Hz, 1H), 3.72–3.68 (m, 2H), 3.64–3.61 (m, 1H), 3.56–3.55 (m, 1H), 3.41–3.35 (m, 2H); ^{13}C NMR (75 MHz, CDCl_3): $\delta = 161.8, 143.1, 125.7, 116.9, 97.3, 74.4, 71.7, 70.4, 63.2, 61.0$; HRMS–ES: calcd for $\text{C}_{12}\text{H}_{14}\text{N}_4\text{O}_7\text{Na}$ requires 349.0760; found $m/z = 349.0760$ $[\text{M} + \text{Na}]^+$.

(*p*-Nitrophenyl) 2,3,4,6-tetra-*O*-acetyl- α -D-galactopyranoside **54a** was prepared according to procedure B was obtained as colorless oil.^[62] For compound **54a** (49.0 mg, 51%): ^1H NMR (300 MHz, CDCl_3): $\delta = 8.25$ – 8.19 (m, 2H), 7.20–7.15 (m, 2H), 5.89 (d, $J = 3.6$ Hz, 1H), 5.58–5.51 (m, 2H), 5.33 (dd, $J = 3.6, 10.2$ Hz, 1H), 5.27 (t, $J = 6.0$ Hz, 1H), 4.14–4.02 (m, 2H), 2.17 (s, 3H), 2.08 (s, 3H), 2.02 (s, 3H), 1.93 (s, 3H); ^{13}C NMR (75 MHz, CDCl_3): $\delta = 170.4, 170.3, 170.2, 170.1, 160.8, 143.0, 125.8, 116.5, 94.6, 67.7, 67.5, 67.3, 67.1, 61.3, 20.68, 20.63, 20.59, 20.54$.

(*p*-Nitrophenyl) 2,3,4,6-tetra-*O*-acetyl- β -D-galactopyranoside **54b** was prepared according to procedure B was obtained as colorless oil.^[62] For compound **54b** (8.0 mg, 9%): ^1H NMR (300 MHz, CDCl_3): $\delta = 8.24$ – 8.21 (m, 2H), 7.15–7.08 (m, 2H), 5.50 (d, $J = 3.6$ Hz, 1H), 5.20 (d, $J = 8.1$ Hz, 1H), 5.16 (dd, 1H), 4.23–4.11 (m, 4H), 2.20 (s, 3H, AcO), 2.08 (s, 6H, AcO), 1.94 (s, 3H, AcO).

(*p*-Nitrophenyl) 3,4,6-tetra-*O*-acetyl-2-azido-2-deoxy- α -D-

galactopyranoside **55** was prepared according to procedure B was obtained as colorless oil. For compound **55** (55.0 mg, 60%): ^1H NMR (300 MHz, CDCl_3): δ = 8.25–8.20 (m, 2H), 7.26–7.18 (m, 2H), 5.73 (d, J = 3.6 Hz, 1H), 5.58–5.51 (m, 2H), 5.26 (t, J = 6.6 Hz, 1H), 4.12–4.06 (m, 2H), 3.93 (dd, J = 3.6, 10.8 Hz, 1H), 2.19 (s, 3H), 2.15 (s, 3H), 1.94 (s, 3H); ^{13}C NMR (75 MHz, CDCl_3): δ = 170.5, 170.2, 170.1, 161.0, 143.7, 126.2, 117.2, 97.2, 68.6, 68.4, 67.4, 61.6, 57.5, 21.0, 20.97, 20.93; HRMS–ES: calcd for $\text{C}_{18}\text{H}_{20}\text{N}_4\text{O}_{10}$ requires 452.1179; found m/z = 452.1195 $[\text{M}]^+$.

(*p*-Nitrophenyl) 2,3,4-tri-*O*-acetyl- α -L-rhamnopyranoside **56** was prepared according to procedure B was obtained as colorless oil. For compound **56** (43.0 mg, 45%): ^1H NMR (300 MHz, CDCl_3): δ = 8.21–8.16 (m, 2H), 7.18–7.13 (m, 2H), 5.55 (d, J = 3.6 Hz, 1H), 5.54–5.41 (m, 2H), 5.18 (t, J = 9.9 Hz, 1H), 3.90–3.85 (m, 1H), 2.20 (s, 3H), 2.06 (s, 3H), 1.97 (s, 3H), 1.19 (d, J = 6.3 Hz, 3H); ^{13}C NMR (75 MHz, CDCl_3): δ = 170.0, 169.9, 169.7, 160.3, 142.8, 125.7, 116.2, 95.4, 70.4, 69.4, 69.1, 68.4, 20.7, 20.64, 20.60, 17.3; HRMS–ES: calcd for $\text{C}_{18}\text{H}_{21}\text{NO}_{10}$ requires 411.1165; found m/z = 411.1168 $[\text{M}]^+$.

(*p*-Nitrophenyl) 2,3,4,6-tetra-*O*-acetyl- α -D-mannopyranoside **57** was prepared according to procedure B was obtained as colorless oil. For compound **57** (52.0 mg, 55%): ^1H NMR (300 MHz, CDCl_3): δ = 8.25–8.19 (m, 2H), 7.25–7.17 (m, 2H), 5.62 (d, J = 3.6 Hz, 1H), 5.55 (dd,

$J = 3.3, 9.9$ Hz, 1H), 5.46 (dd, $J = 3.6, 9.9$ Hz, 1H), 5.38 (t, $J = 9.9$ Hz, 1H), 4.30 (dd, $J = 5.4, 12.0$ Hz, 1H), 4.12–3.97 (m, 2H), 2.24 (s, 3H), 2.04 (s, 3H), 2.03 (s, 3H), 1.99 (s, 3H); ^{13}C NMR (75 MHz, CDCl_3): $\delta = 170.3, 169.9, 169.6, 160.0, 143.0, 125.8, 116.4, 95.6, 69.7, 68.8, 68.4, 65.5, 61.8, 20.8, 20.7, 20.63, 20.60$; HRMS–ES: calcd for $\text{C}_{20}\text{H}_{23}\text{NO}_{12}$ requires 470.1299; found $m/z = 470.1301$ $[\text{M} + \text{H}]^+$.

6.4 Methylumbelliferyl 3,4,6-tri-*O*-acetyl-2-azido-2-deoxy- α -D-galactopyranoside **58**

To a mixture of per-*O*-acetyl-D-galactopyranosyl trichloroacetimidate **48** (600 mg, 1.26 mmol), 4-methylumbelliferone **33** (270 mg, 1.51 mmol), and MS-4Å (1.20 g) in CH_2Cl_2 (5.0 mL), TMSOTf (220 μL , 1.26 mmol) was added. Upon stirring at -20 °C for 8 h under N_2 , the reaction mixture was diluted with CH_2Cl_2 (10 mL). The resulting CH_2Cl_2 solution was washed with sat. NaHCO_3 (20 mL \times 2), water (20 mL \times 1), brine (20 mL \times 1), dried over MgSO_4 , filtered and then concentrated for column chromatography purification over silica gel. Elution with 1:6 v/v EtOAc/hexane mixture provided compound **58** as a yellowish oily liquor (430 mg, 70%): ^1H NMR (300 MHz, CDCl_3): $\delta = 7.56$ (d, 1H), 7.11 (s, 1H), 7.04 (d, 1H), 6.19 (s, 1H), 5.70 (d, $J = 3.6$ Hz, 1H), 5.57–5.41 (m, 2H), 4.30 (t, $J = 3.6$ Hz, 1H), 4.12–4.05 (m, 2H), 3.90 (dd, $J = 8.7, 10.8$ Hz, 1H), 2.47 (s, 3H), 2.19 (s, 3H), 2.11 (s, 3H), 1.94 (s, 3H); ^{13}C NMR (75 MHz, CDCl_3): $\delta = 170.7, 170.3, 170.2, 161.2, 159.0, 155.2, 152.7, 126.2, 115.9, 114.3, 113.5, 104.7, 97.4, 68.5, 68.2, 67.5,$

61.6, 57.5, 21.0, 20.98, 20.9, 19.0.

6.5 4-Methylumbelliferyl 2-azido-4,6-*O*-benzylidene-2-deoxy- α -D-galactopyranoside **59**

To a MeOH solution (2.0 mL) of **58** (100 mg, 0.20 mmol), a piece of freshly cut sodium was added and the mixture was stirred initially at 0 °C before being gradually brought up to room temperature. Upon complete deacetylation as assessed by TLC (ca 2 h), the reaction mixture was neutralized with IR-120 H⁺, which was subsequently removed by filtration. After removal of MeOH by rotary evaporator and drying under *vacuo* for couple of hours, the crude product was re-suspended in CH₃CN (2.0 mL), to which benzaldehyde dimethyl acetal (45 μ L, 0.3 mmol) and *p*-toluenesulfonic acid monohydrate (TsOH) (4.0 mg, 0.02 mmol) were added. After stirring at rt for 4 h, the mixture was diluted with CH₂Cl₂ (6.0 mL), and the resulting solution was washed with sat. NaHCO₃ (10 mL \times 2), water (10 mL \times 1), brine (10 mL \times 1), dried over MgSO₄, filtered and concentrated for column chromatography purification over silica gel. Elution with 1:1 v/v EtOAc/hexane mixture afforded compound **59** as white amorphous powder (68.0 mg, 70% over two steps): ¹H NMR (300 MHz, CDCl₃): δ = 7.56–7.51 (m, 3H, ArH), 7.41–7.38 (m, 3H, ArH), 7.11–7.05 (m, 2H, ArH), 6.19 (s, 1H, C=CH), 5.76 (d, *J* = 3.6 Hz, 1H, H-1), 5.62 (s, 1H), 4.42–4.39 (m, 2H, H-4, H-5), 4.28 (d, *J* = 12.6 Hz, 1H, H-6), 4.09 (d, *J* = 12.9 Hz, 1H, H-6'), 3.85–3.81 (m, 2H, H-2, H-3), 2.41 (s, 3H, CH₃); ¹³C NMR (75 MHz, CDCl₃): δ =

161.3, 159.3, 155.2, 152.7, 137.4, 129.8, 128.7, 126.6, 126.2, 115.7, 113.6, 113.4, 104.7, 101.6, 97.8, 75.5, 69.3, 67.8, 64.3, 60.5, 53.8, 19.1; HRMS-ES: calcd for C₂₃H₂₁N₃O₇ requires 452.1458; found *m/z* = 452.1452 [M + H]⁺.

6.6 4-Methylumbelliferyl 2-azido-4,6-di-*O*-benzylidene-2-deoxy-3-(2',3',4',6'-tetra-*O*-acetyl-β-D-galactopyranosyl)-α-D-galactopyranoside **60**

To a mixture of per-*O*-acetyl D-galactosyl trichloroacetimidate **47** (108.0 mg, 0.22 mmol), (4-MU) 2-azido-4,6-*O*-benzylidene-2-deoxy-α-D-galactopyranoside **59** (50 mg, 0.11 mmol) and MS-4A (300 mg) in CH₂Cl₂ (2.0 mL), TMSOTf (4.0 μL, 0.022 mmol) was added and the mixture was stirred at -20 °C for 2 h. The reaction mixture was then diluted with CH₂Cl₂ (6.0 mL), which was washed with sat. NaHCO₃ (10 mL × 2), water (10 mL × 1), brine (10 mL × 1), dried over MgSO₄, filtered and concentrated for column chromatography purification over silica gel. Elution with 1:1 v/v EtOAc/hexane elution afforded the titled compound **60** as white amorphous powder (65.0 mg, 75%): ¹H NMR (300 MHz, CDCl₃): δ = 7.57–7.54 (m, 3H), 7.40–7.38 (m, 3H), 7.10–7.07 (m, 2H), 6.19 (s, 1H), 5.80 (d, *J* = 3.6 Hz, 1H), 5.60 (s, 1H), 5.44–5.30 (m, 2H), 5.10 (dd, *J* = 3.0, 10.2 Hz, 1H), 4.91 (d, *J* = 7.8 Hz, 1H), 4.50 (br, 1H), 4.35–3.99 (m, 7H), 3.79 (br, 1H), 2.41 (s, 3H), 2.16 (s, 3H), 2.09 (s, 3H), 2.03 (s, 3H), 1.97 (s, 3H); ¹³C NMR (75 MHz, CDCl₃): δ = 170.7, 170.6, 170.50, 169.8, 161.2, 159.3, 155.3, 152.5, 137.7, 129.4, 128.6,

126.4, 126.3, 115.8, 113.5, 113.3, 105.0, 102.9, 101.0, 98.0, 76.2, 75.8, 71.4, 71.3, 69.3, 69.0, 67.3, 64.6, 61.7, 58.8, 21.15, 21.10, 20.97, 20.90, 19.0; HRMS-ES: calcd for C₃₇H₃₉N₃O₁₆ requires 781.2330; found *m/z* = 781.2299 [M]⁺.

6.7 4-Methylumbelliferyl (4-MU) 2-acetamido-2-deoxy-3-(β-D-galactopyranosyl)-α-D-galactopyranoside 24

A mixture of **60** (36.0 mg, 0.046 mmol) and 5% Pd/C (36.0 mg) in MeOH (2.0 mL) was stirred at rt under 1 atm H₂ for 2 h. The reaction mixture was then filtered through celite and the filtrate was concentrated by rotary evaporator. The crude residue was re-suspended in a mixture of pyridine (1.0 mL) and Ac₂O (1.0 mL), and then stirred at rt for 1 h. Excess solvent and reagent were removed by rotary evaporator, and the residue was dissolved in MeOH (2.0 mL), to which a piece of freshly cut sodium (ca 20 mg) was added. The resulting mixture was stirred for 2 h from 0 °C to rt and followed by neutralization with IR-120 H⁺ resin. After filtration removal of resin, MeOH was reduced by rotary evaporator. The crude residue was then re-suspended in 90% aqueous acetic acid (1.0 mL) and stirring at 60 °C for 1 h. Upon complete deacetalation as assessed by TLC, the solution was concentrated with rotary evaporator for column chromatography purification over reversed phase RP-C18 silica gel with MeOH/H₂O mixture elution (gradient from 25% to 30% MeOH) to afford the 4-MU α-T-antigen **24** (10 mg, 40% over four steps) as white glassy solid: ¹H NMR (300 MHz, CD₃OD): δ = 7.79 (d, 1H),

7.26–7.20 (m, 2H), 6.26 (d, 1H), 5.73 (d, $J = 3.6$ Hz, 1H), 4.71 (dd, $J = 3.6, 11.1$ Hz, 1H), 4.61 (d, $J = 6.9$ Hz, 1H), 4.33 (d, $J = 2.4$ Hz, 1H), 4.25 (dd, $J = 3.0, 11.1$ Hz, 1H), 3.99 (t, $J = 5.7, 11.1$ Hz, 1H), 3.93 (d, $J = 3.0$ Hz, 1H) 3.83–3.79 (m, 3H), 3.74–3.70 (m, 2H), 3.60–3.56 (m, 2H), 2.50 (d, 3H), 2.06 (s, 3H); ^{13}C NMR (75 MHz, CD_3OD): $\delta = 174.2, 163.2, 161.4, 156.0, 155.4, 127.3, 116.2, 115.0, 112.9, 106.4, 105.5, 98.3, 78.4, 76.8, 74.7, 73.5, 72.5, 71.4, 70.3, 69.7, 62.6, 62.4, 22.7, 18.6$; HRMS–ES: calcd for $\text{C}_{24}\text{H}_{31}\text{NO}_{13}\text{Na}$ requires 564.1693; found $m/z = 564.1689$ [$\text{M} + \text{Na}$] $^+$.



參考文獻

- [1] (a) Seeberger, P. H. *Chem. Soc. Rev.* **2008**, *37*, 19-28 and references cited therein. (b) Lee, J.-C.; W.-A. Greenberg, C.-H. Wong, *Nature Protocols* **2006**, *1*, 3143-3152. (c) Y. Wang, X.-S. Ye, L.-H. Zhang, *Org. Biomol. Chem.* **2007**, *5*, 2189-2200. (d) S. Valerio, A. Pastore, M. Adinolfi, A. Iadonisi, *J. Org. Chem.* **2008**, *73*, 4497-4503.
- [2] (a) R. R. Schmidt, A. Toepfer, *Tetrahedron Letters* **1991**, *32*, 3353. (b) W. Günther, H. Kunz, *Carbohydr. Res.* **1992**, *228*, 217-241. (c) C. Unverzagt, *Chem. Eur. J.* **2003**, *9*, 1369-1376. (d) V. Y. Dudkin, D. Crich, *Tetrahedron Lett.* **2003**, *44*, 1787-1789. (e) E. Attolino, A. J. Fairbanks, *Tetrahedron Lett.* **2007**, *48*, 3061-3064. (f) V. K. Srivastava, C. Schuerch, *J. Org. Chem.* **1982**, *46*, 1121-1126. (g) Adel A.-H. Abdel-Rahman, S. Jonke, El. S. H. El-Ashry, R. R. Schmidt, *Angew. Chem., Int. Ed.* **2002**, *41*, 2972-2974; *Angew. Chem.* **2002** *116*, 3100-3103. (h) D. Crich, S. Sun, *J. Org. Chem.* **1996**, *21*, 4506-4507. (i) B. Sun, B. Srinivasan, X.-F. Huang, *Chem. Eur. J.* **2008**, *14*, 7072-7081. (j) R. Weingart, R. R. Schmidt, *Tetrahedron Lett.* **2000**, *41*, 8753-8758. (k) K.-S. Kim, J. H. Kim, Y.-Jon Lee, Y.-Jun Lee, J. Park, *J. Am. Chem. Soc.*, **2001**, *123*, 8477-8481. (l) S. Tanaka, M. Takashina, H. Tokimoto, Y. Fujimoto, K. Tanaka, K. Fukase, *Synlett* **2005**, 2325-2328. (m) T. Tsuda, R. Arihara, S. Sato, M. Koshihara, S. Nakamura, S. Hashimoto, *Tetrahedron* **2005**, *61*, 10719-10733.

- [3] (a) Dwek, R. A. *Chem. Rev.* **1996**, *96*, 683. (b) Bertozzi, C. R.; Kiessling, L. L. *Science* **2001**, *291*, 2357. (c) Fraser-Reid, B. O.; Tatsuta, K. in *Glycoscience: Chemistry and Chemical Biology*, Thiem, J. Ed., Springer, **2001**, I-III.
- [4] (a) Burton, D. R. *Proc. Natl. Acad. Sci. USA.* **1997**, *94*, 10018. (b) Ruprecht, R. M.; Hofmann-Lehmann, R.; Smith-Franklin, B. A.; Rasmussen, R. A.; Liska, V.; Vlasak, J.; Xu, W.; Baba, T. W.; Chenine, A. L.; Cavacini, L. A.; Posner, M. R.; Katinger, H.; Stigler, G.; Bernacky, B. J.; Rizvi, T. A.; Schmidt, R.; Hill, L. R.; Keeling, M. E.; Montefiori, D. C.; McClure, H. M. *Transfus. Clin. Biol.* **2001**, *8*, 350. (c) Mascola, J. R. *Vaccine* **2002**, *20*, 1922 .
- [5] (a) Scanlan, C. N.; Pantophlet, R.; Wormald, M. R.; Saphire, E. O.; Stanfield, R.; Wilson, I. A.; Katinger, H.; Dwek, R. A.; Rudd, P. M.; Burton, D. R. *J. Virol.* **2002**, *76*, 7306. (b) Sanders, R. W.; Venturi, M.; Schiffner, L.; Kalyanaraman, R.; Katinger, H.; Lloyd, K. O.; Kwong, P. D.; Moore, J. P. *J. Virol.* **2002**, *76*, 7293.
- [6] Lee, H. -K.; Scanlan, C. N.; Huang, C. -Y.; Chang, A. Y.; Calarese, D. A.; Dwek, R. A.; Rudd, P. M.; Burton, D. R.; Wilson, I. A.; Wong, C. H. *Angew. Chem., Int. Ed.* **2004**, *43*, 1000.
- [7] (a) Paulsen, H.; Lebuhn, R.; Lockhoff, O. *Carbohydr. Res.* **1982**, *103*, C7. (b) Paulsen, H.; Lebuhn, R.; Lockhoff, O. *Carbohydr. Res.* **1984**, *130*, 85.
- [8] (a) Boons, G. J.; Zhu, T. *Synlett.* **1997**, 809. (b) Ley, S. V.; Priepke, H. W. M. *Angew. Chem., Int. Ed.* **1994**, *33*, 2292. (c) Yamada, H.; Harada, T.; Takahashi, T. *J. Am. Chem. Soc.* **1994**, *116*, 7919.
- [9] Mootoo, D. R.; Konradsson, P.; Udodong, U. E.; Fraser-Raid, B. *J. Am. Chem. Soc.* **1988**, *110*, 5583. (b) Fraser-Raid, B.; Wu, Z.; Udodong, U. E.; Ottosson, H. *J. Org. Chem.* **1990**, *55*, 6068.

- [10] Ye, X. -S.; Wong, C. -H. *J. Org. Chem.* **2000**, *65*, 2410.
- [11] (a) Mong, K. -K. T.; Wong, C. -H. *Angew. Chem., Int. Ed.* **2002**, *41*, 4087. (b) Mong, K. -K. T.; Huang, C. -Y.; Wong, C. -H. *J. Org. Chem.* **2003**, *68*, 2135.
- [12] Douglas, N. L.; Ley, S. V.; Lücking, U.; Warriner, S. L. *J. Chem. Soc., Perkin Trans.* **1998**, *1*, 51.
- [13] Zhang, Z.; Ollmann, I. R.; Ye, X. -S.; Wischnat, R.; Baasov, T.; Wong, C. -H. *J. Am. Chem. Soc.* **1999**, *121*, 734.
- [14] (a) Hashihayata, T.; Ikegai, K.; Takeuchi, K.; Jona, H.; Mukaiyama, T. *Bull. Chem. Soc. Jpn.* **2003**, *76*, 1829. (b) Yamada, H.; Harada, T.; Takahashi, T. *J. Am. Chem. Soc.* **1994**, *116*, 7919. (c) Tanaka, H.; Adachi, M.; Takahashi, T. *Tetrahedron Lett.* **2004**, *45*, 1433.
- [15] Danishefsky, S. J.; McClure, K. F.; Randolph, J. T.; Ruggeri, R. R. *B. Science* **1993**, *260*, 1307.
- [16] Nguyen, H. M.; Poole, J. L.; Gin, D. Y. *Angew. Chem., Int. Ed.* **2001**, *40*, 414.
- [17] Yamago, S.; Yamada, T.; Hara, O.; Ito, H.; Mino, Y.; Yoshida, J. *Org. Lett.* **2001**, *3*, 3867.
- [18] Crich, D.; Sun, S. *J. Am. Chem. Soc.* **1998**, *120*, 435.
- [19] Huang, X.; Huang, L.; Wang, H.; Ye, X. -X. *Angew. Chem., Int. Ed.* **2001**, *116*, 5221.
- [20] Ohnishi, Y.; Ando, H.; Kawai, T.; Nakahara, Y.; Ito, Y. *Carbohydr. Res.* **2000**, *328*, 263.
- [21] Codee, J. D. C.; Krock, L.; Castagner, B.; Seeberger, P. H. *Chem. Eur. J.* **2003**, *9*, 1369-1376.
- [22] Baek, J. Y.; Choi, T. J.; Jeon, B. H.; Kim, K. S. *Angew. Chem., Int. Ed.* **2006**, *45*, 7436.
- [23] Crich, D.; Smith, M.; Yao, Q.; Picione, J. *Synthesis* **2001**, *2*, 323.

- [24] Li, Z.; Gildersleeve, J. C. *J. Am. Chem. Soc.* **2006**, *128*, 11612.
- [25] (a) Becker, D. J.; Lowe, J. B. *Glycobiology* **2003**, *13*, 41R. (b) Hopper, L. V.; Gordon, J. I. *Glycobiology* **2001**, *11*, 1R.
- [26] Henrissat, B. *Biochem. J.* **1991**, *280*, 309.
- [27] (a) Aminoff, D.; Furukawa, K. *J. Biol. Chem.* **1970**, *7*, 1659. (b) Sano, M.; Hayakawa, K.; Kato, I. *J. Biol. Chem.* **1992**, *267*, 1522. (c) Butter, T. D. *Biochem. J.* **1991**, *279*, 189. (d) Carlsen, R.; Pierce, J. G. *J. Biol. Chem.* **1972**, *247*, 23.
- [28] Vanhooren, P. T.; Vandamme, E. J. *J. Chem. Technol. Biotechnol.* **1999**, *74*, 479.
- [29] (a) Spassova, M. K.; Bommam, W. G.; Ragupathi, G.; Sukenick, G.; Danishefsky, S. J.; Livingston, P. O. *J. Org. Chem.* **2005**, *70*, 3383. (b) Ragupathi, G.; Koide, F.; Livingston, P. O.; Cho, Y. S.; Endo, A.; Wan, Q.; Spassova, M. K.; Keding, S. J.; Allen, J.; Ouerfelli, O.; Wilson, R. M.; Danishefsky, S. J. *J. Am. Chem. Soc.* **2006**, *128*, 2715.
- [30] (a) Stachulski, A. V.; Jenkins, G. N. *Nat. Prod. Rep.* **1998**, 173–186. (b) Rodriguez, M. J.; Snyder, N. J.; Zweifel, M. J.; Wilkie, S. C.; Stack, D. R.; Cooper, R. D.; Nicas, T. I. Mullen, D. A.; Butler, T. F.; Thompson, R. C. *J. Antibiot.* **1998**, *51*, 560–569. (c) Malabarba, A.; Nicas, T. I.; Thompson, R. C. *Med. Res. Rev.* **1997**, *17*, 69–137. (d) Smythe, C.; Cohen, P. *Eur. J. Biochem.* **1991**, *200*, 625–631.
- [31] (a) Troelsen, J. T.; Mitchelmore, C.; Spodsberg, N.; Jensen, A. M.; Norén, O.; Sjöström, H. *Biochem. J.* **1997**, *322*, 833–838. (b) Okayama, M.; Kimata, K.; Suzuki, K. *Biochem. J.* **1973**, *74*, 1069–1073. (c) Freeze, H. H.; Sampath, D.; Varki, A. *J. Biol.*

- Chem.* **1993**, 268, 1618–1627. (d) Fritz, T. A.; Lugemwa, F. N.; Sarkar, A. K.; Esko, J. D. *J. Biol. Chem.* **1994**, 269, 300–307.
- [32] (a) Capon, B.; Thomson, J. W. *Bioorg. Chem.* **1979**, 8, 147–173. (b) Vinetz, J. M.; Valenzuela, J. G.; Specht, C. A.; Aravind, L.; Langer, R. C.; Ribeiro, J. M. C.; Kaslow, D. C. *J. Biol. Chem.* **2000**, 275, 10331–10341. (c) Omero, C.; Horwitz, B. A.; Chet, I. J. *Microbiol. Methods* **2001**, 43, 165–169. (d) Howard, M. B.; Ekborg, N. A.; Taylor, L. E.; Weiner, R. M.; Hutcheson, S. W. J. *Bacteriol.* **2004**, 186, 297–1303. (e) Pritsch, K.; Raidl, S.; Marksteiner, E.; Blaschke, H.; Agerer, R.; Schloter, M.; Hartmann, A. J. *Microbiol. Methods* **2004**, 58, 233–241. (f) Michael A. *Am. Chem. J.* **1879**, 1, 306.
- [33] (a) Jensen, K. J. *J. Chem. Soc., Perkin Trans. 1* **2002**, 2219–2233. (b) Gervay-Hague, J.; Lam, S.-N. *Org. Lett.* **2003**, 5, 4219–4222.
- [34] (a) Helferich, B.; Schmitz-Hillebrecht, E. *Ber.* **1933**, 66B, 378–383. (b) Montgomery, E. M.; Richtmyer, N. K.; Hudson, C. S. *J. Am. Chem. Soc.* **1942**, 64, 690–694. (c) Smits, E.; Engberts, J. B.; Kellogg, R. M.; van Doren, H. A. *J. Chem. Soc., Perkin Trans. 1* **1996**, 2873–2877. (d) Hakamata, W.; Nishio, T.; Oku, T. *Carbohydr. Res.* **2000**, 324, 107–115. (e) Yamanoi, T.; Yamazaki, I. *Tetrahedron Lett.* **2001**, 42, 4009–4011. (f) Aich, U.; Loganathan, D. *Carbohydr. Res.* **2006**, 341, 19–28.
- [35] (a) Szweda, R.; Spohr, U.; Lemieux, R. U.; Schindler, D.; Bishop, D. F.; Desnick, R. J. *Can. J. Chem.* **1989**, 67, 1388–1391. (b) Matsumoto, T.; Katsuki, M.; Suzuki, K. *Chem. Lett.* **1989**, 437–440. (c) Yamaguchi, M.; Horiguchi, A.; Fukuda, A.; Minami,

- T. *J. Chem. Soc., Perkin Trans. 1* **1990**, 1079–1082. (d) Chiappe, C.; Lo-Moro, G.; Munforte, P. *Tetrahedron*, **1997**, *53*, 10471–10478. (e) Jensen, K.-J.; Meldal, M.; Bock, K. *J. Chem. Soc., Perkin Trans. 1* **1993**, 2119–2129. (f) Ganguli, A. R. S.; Coward, J. K. *Tetrahedron: Asymmetry* **2005**, *16*, 411–424.
- [36] (a) Gryniewicz, G. *Carbohydr. Res.* **1977**, *53*, C11–C12. (b) Garegg, P. J.; Iversen, T.; Norberg, T. *Carbohydr. Res.* **1979**, *73*, 313–314. (c) Roush, W. R.; Lin, X.-F. *J. Org. Chem.* **1991**, *56*, 5740–5742. (d) Imamura, A.; Ando, H.; Ishida, H.; Kiso, M. *Org. Lett.* **2005**, *7*, 4415–4418.
- [37] (a) Dowlut, M.; Hall, D.-G.; Hindsgaul, O. *J. Org. Chem.* **2005**, *70*, 9809–9813. (b) Tanaka, Y.; Takahashi, Y.; Shinose, M.; Omura, S.; Iwase, H.; Hotta, K. *Ferment. Bioeng.* **1998**, *85*, 381–387. (c) Ashida, H.; Yamamoto, K.; Murata, T.; Usui, T.; Kumagai, H. *Arch. Biochem. Biophys.* **2000**, *373*, 394–400. (d) Hung, P. Y. C.; Madej, M.; Koganty, R. R.; Longenecker, B. M. *Cancer Res.* **1990**, *50*, 4308. (e) Livingston, P. O.; Koganty, R.; Longenecker, B. M.; Lloyd, K. O.; Calves, M. *Vaccine Res.* **1992**, *1*, 99.
- [38] White, W. J.; Schray, K. J.; Legler, G.; Alhadeff, J. A. *Biochem. Biophys. Acta* **1987**, *912*, 132.
- [39] Mccarter, W. J.; Withers, S. G. *Curr. Opin. Struct. Biol.* **1994**, *4*, 885.
- [40] Johnson, S. W.; Alhadeff, J. A. *Comp. Biochem. Physiol.* **1991**, *99B*, 479.
- [41] (a) Fahrenheit, G.; Westphal, O. *Liebigs Ann. Chem.* **1968**, *720*, 177. (b) Fahrenheit, G.; Westphal, O. *Chem. Ber.* **1956**, *89*, 582. (c) Hakamata, W.; Nishio, T.; Oku, T. *Carbohydr. Res.* **2000**, *324*,

- [42] (a) Liptak, A.; Nanasi, P.; Neszmelyi, A.; Wagner, H. *Tetrahedron* **1980**, *36*, 1261. (b) Lemieux, R. U.; Driguez, H. *J. Am. Chem. Soc.* **1975**, *97*, 4069. (c) Nikrad, P. V.; Beierbeck, H.; Lemieux, R. U. *Can. J. Chem.* **1992**, *70*, 241. (d) Danishefsky, S. J.; Bilodeau, M. T. *Angew. Chem., Int. Ed.* **1996**, *35*, 1380.
- [43] Koenigs, W.; Knorr, E. *Ber. Dtsch. Chem. Ges.* **1901**, *34*, 957.
- [44] Lemieux, R. U.; Hendriks, K. B.; Stick, R. V.; James, K. *J. Am. Chem. Soc.* **1975**, *97*, 4056.
- [45] Matsumoto, T.; Katsuki, M.; Suzuki, K. *Chem. Lett.* **1989**, 437.
- [46] (a) Garegg, P. J. *Adv. Carbohydr. Chem. Biochem.* **1997**, *52*, 179. (b) Ludewig, M.; Thiem, J. *Synthesis* **1998**, 56. (c) Mesta, S.; Pinto, B. M. *J. Org. Chem.* **1993**, *58*, 3269.
- [47] Pougny, J. R.; Jacquinet, J. C.; Nassr, M.; Duchet, D.; Milat, M. L.; SInay, P. *J. Am. Chem. Soc.* **1977**, *99*, 6762.
- [48] (a) Schmidt, R. R. *Angew. Chem., Int. Ed.* **1986**, *25*, 212. (b) Schmidt, R. R.; Kinzy, W. *Adv. Carbonhydr. Chem. Biochem.* **1994**, *50*, 21. (c) Schmidt, R. R. in *Modern Methods in carbohydrate Synthesis*, Khan, S. H.; Oneill, R. A. Ed., Harwood Academic, Netherlands, 1996, p. 20. (d) Toptfer, A.; Kinzy, W.; Schmidt, R. R. *Lisbig's Ann. Chem.* **1994**, 449. (e) Schmidt, R. R.; Stumpp, M. *Lisbig's Ann. Chem.* **1984**, 680. (f) Jiang, Z. H.; Schmidt, R. R. *Lisbig's Ann. Chem.* **1992**, 975.
- [49] Anslyn, E. A.; Dougherty, D. A. in *Modern Physical Organic Chemistry*, Anslyn, E. A. Ed., Sausalito, California, 2004, p173.
- [50] D. Crich, S. Sun, *Tetrahedron* **1998**, *54*, 8321–8348.
- [51] C.-S. Chao, C.-W. Li, M.-C. Chen, S.-S. Chang, K.-K. T. Mong, **Submitted**.
- [52] Mukhopadhyay, B. *J. Org. Chem.* **2008**, *73*, 6924.

- [53] Irina A.; Ivanova, A. J.; Ross, M. A. J. F.; Andrei, V. N. *J. Chem. Soc., Perkin Trans. 1* **1999**, 1743.
- [54] Roy, S.; Roy, N. *J. Carbohydr. Chem.* **2003**, *22*, 521.
- [55] Ethan, D. G.-B.; Robert, V. S. *Org. Lett.* **2007**, *9*, 3797.
- [56] Gildersleeve, J.; Pascal, R. A.; Kahne, D. *J. Am. Chem. Soc.* **1998**, *120*, 5961.
- [57] Cumpstey, I.; Chayajarus, K.; Fairbanks, A. J.; Redgrave, A. J.; Seward, C. M. P. T. *Tetrahedron: Asymmetry* **2004**, *15*, 3207.
- [58] Crich, D.; Banerjee, A.; Wenju, L.; Qingjia, Y. *J. Carbohydr. Chem.* **2005**, *24*, 415.
- [59] Crich, D.; Sun, S. *J. Org. Chem.* **1997**, *62*, 1198.
- [60] Schmidt, R. R.; Wegmann, B.; Jung, K.-H. *Liebigs Ann. Chem.* **1991**, *2*, 121.
- [61] (a) Cook, B.; Bhakta, S.; Biegel, T.; Bowman, K. G.; Armstrong, J. I.; Hemmerich, S.; Bertozzi, C. R. *J. Am. Chem. Soc.* **2000**, *36*, 8612–8622. (b) Rele, S. M.; Iyer, S. S.; Baskaran, S.; Chaikof, E. L. *J. Org. Chem.* **2004**, *26*, 9159–9170. (c) Fuente, J. M. D.; Penades, S. *Tetrahedron Asymmetry*, **2002**, *13*, 1879–1888. (d) Grundler, G.; Schmidt, R. R. *Liebigs Ann. Chem.* **1984**, *11*, 1826–1847. (e) Nicolaou, K. C.; Pfefferkorn, J. A.; Roecker, A. J.; Cao, G.-Q.; Barluenga, S.; Mitchell, H. J. *J. Am. Chem. Soc.* **2000**, *122*, 9939–9953. (f) Carcabal, P.; Huenig, I.; Gamblin, D. P.; Liu, B.; Jockusch, R. A.; Kroemer, R. T.; Snoek, L. C.; Fairbanks, A. J.; Davis, B. G.; Simons, J. P. *J. Am. Chem. Soc.* **2006**, *128*, 1976–1981.
- [62] Kawano, S. I.; Tamaru, S. I.; Fujita, N.; Shinkai, S. *Chem. Eur. J.* **2004**, *2*, 343–351.
- [63] Blanc, M. *Carbohydr. Res.* **1978**, *67*, 305–323.

- [64] Kawano, S. I.; Tamaru, S. I.; Fujita, N.; Shinkai, S. *Chem. Eur. J.* **2004**, *2*, 343–351.
- [65] Onodera, E. A. *Carbohydr. Res.* **1968**, *7*, 27–35.
- [66] Onodera, E. A. *J. Org. Chem.* **1966**, *31*, 2403–2406.



附 錄



¹H NMR spectrum of tolyl 3-*O*-acetyl-6-*O*-benzyl-2-deoxy-2-(trichloroethoxy carbamyl)-1-thio-β-D-glucopyranoside **2**

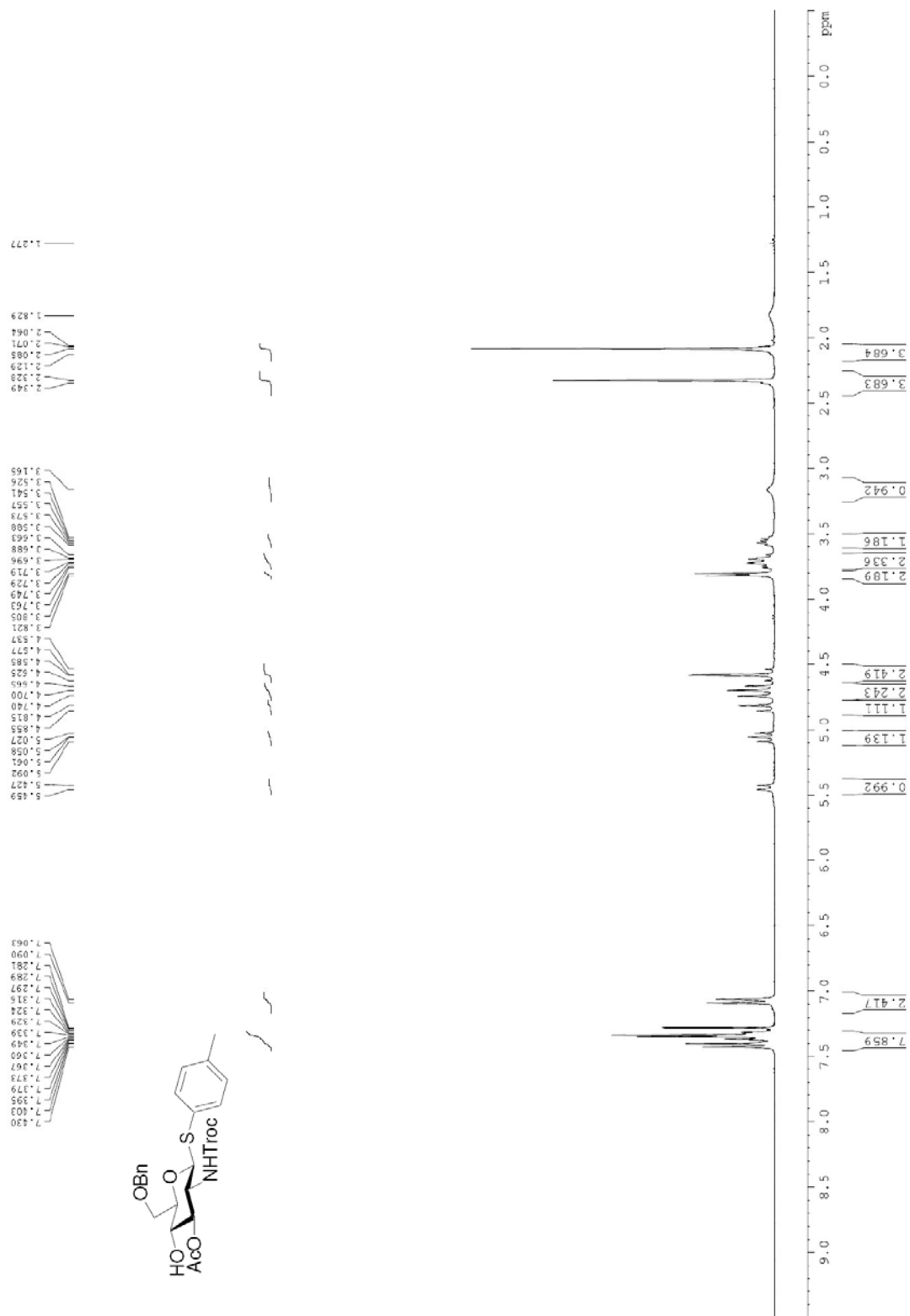

^{13}C NMR spectrum of tolyl 3-*O*-acetyl-6-*O*-benzyl-2-deoxy-2-(trichloroethoxy)carbonyl-1-thio- β -D-glucopyranoside **2**

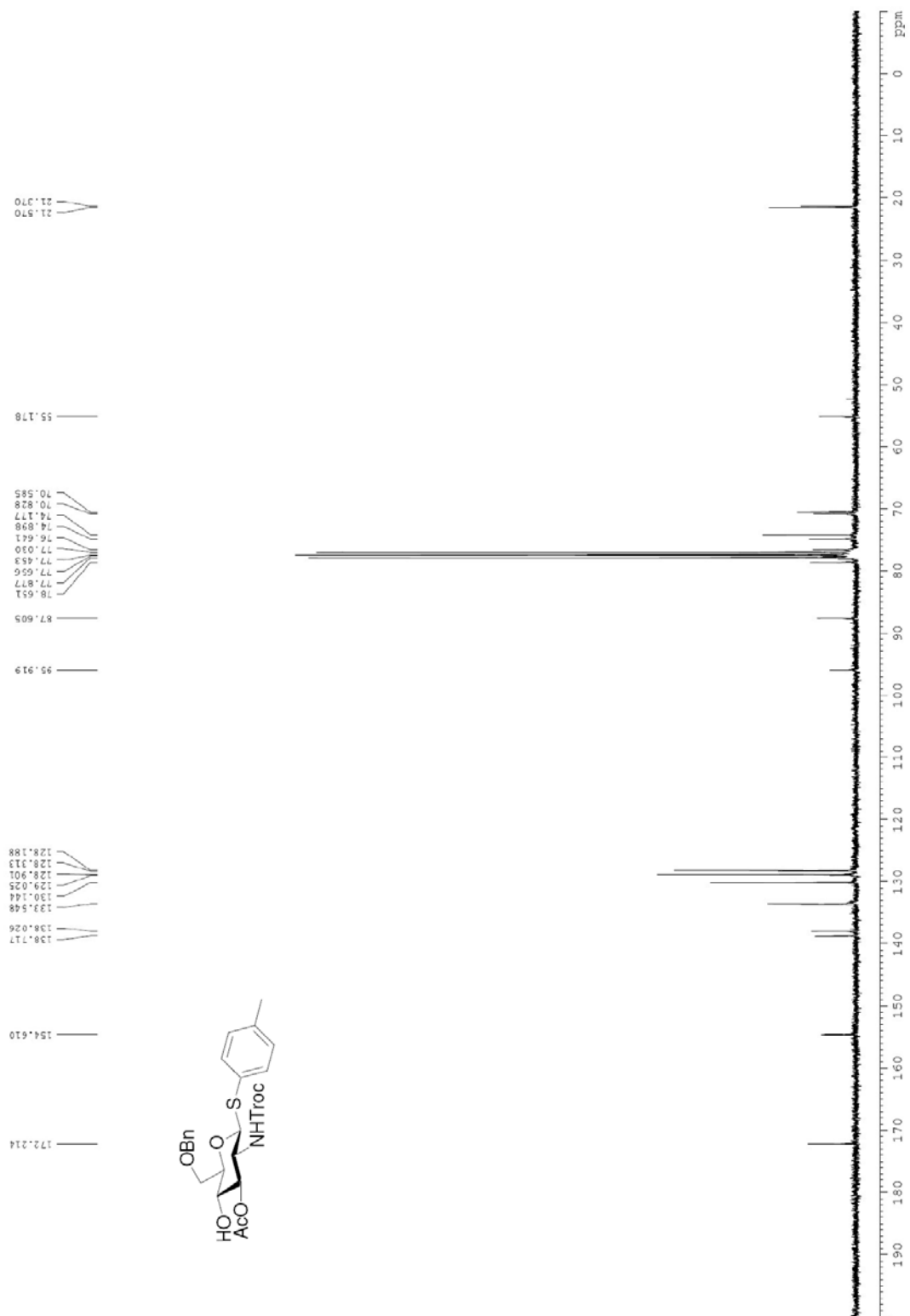

^1H NMR spectrum of tolyl 3-*O*-acetyl-6-*O*-benzyl-2-deoxy-4-*O*-(2-*O*-benzyl-4,6-*O*-benzylidene-3-*O*-*p*-methoxybenzyl- β -D-mannopyranosyl)-2-(trichloroethoxy carbonyl)-1-thio- β -D-glucopyranoside **3**

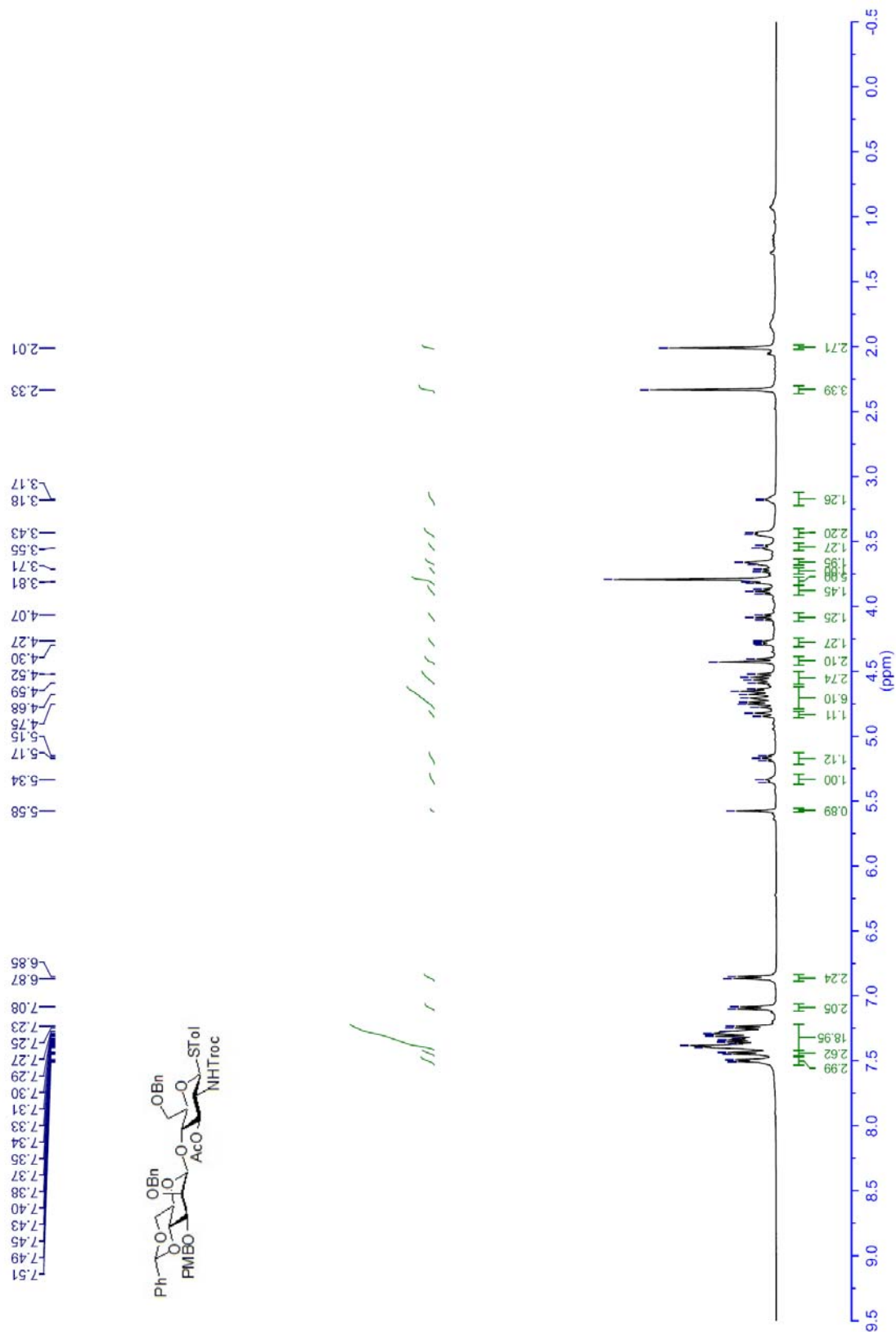

^{13}C NMR spectrum of tolyl 3-*O*-acetyl-6-*O*-benzyl-2-deoxy-4-*O*-(2-*O*-benzyl-4,6-*O*-benzylidene-3-*O*-*p*-methoxybenzyl- β -D-mannopyranosyl)-2-(trichloroethoxycarbonyl)-1-thio- β -D-glucopyranoside **3**

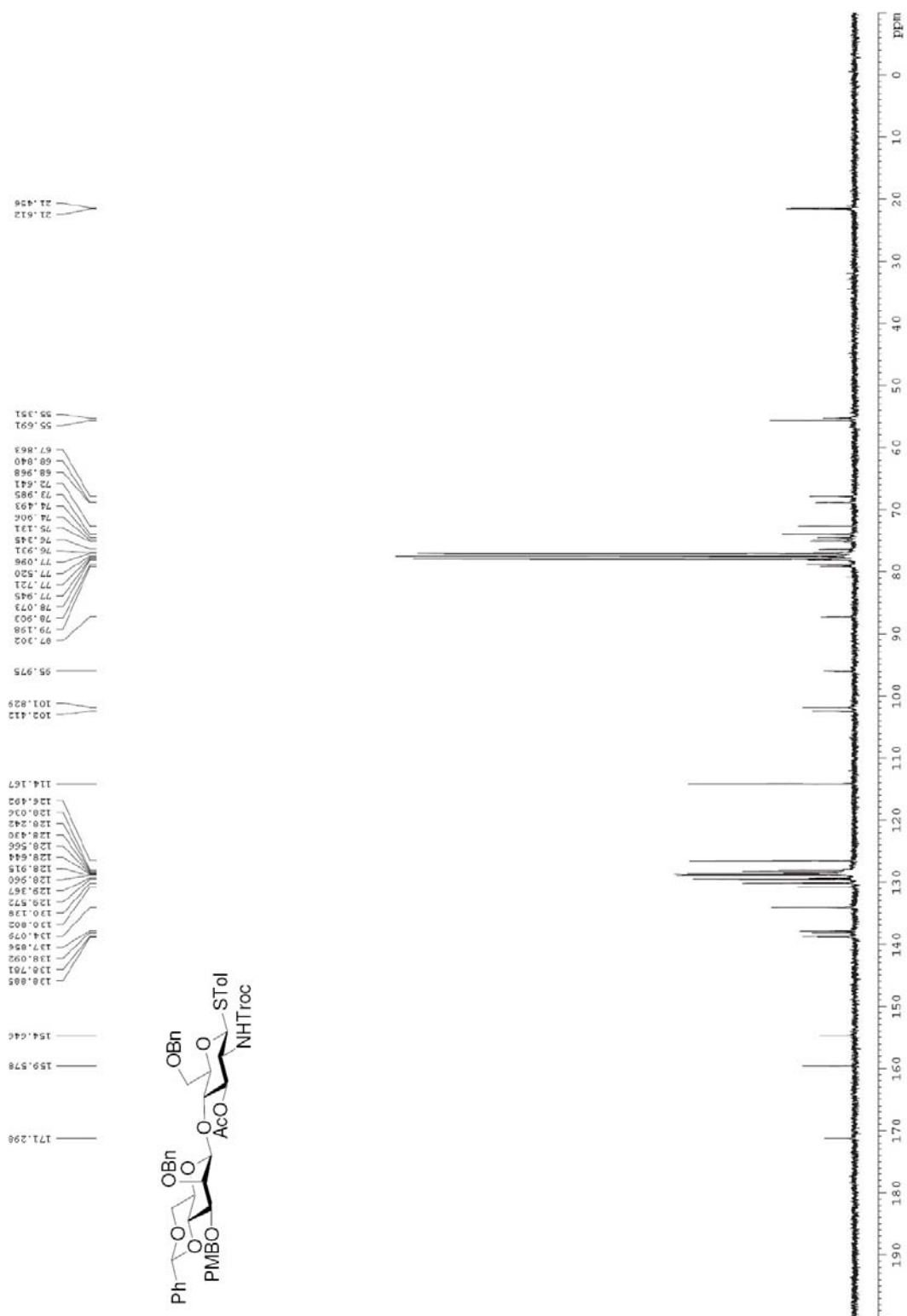

HMQC NMR spectrum of tolyl 3-*O*-acetyl-6-*O*-benzyl-2-deoxy-4-*O*-(2-*O*-benzyl-4,6-*O*-benzylidene-3-*O*-*p*-methoxybenzyl- β -D-mannopyranosyl)-2-(trichloroethyloxycarbonyl)-1-thio- β -D-glucopyranoside **3**

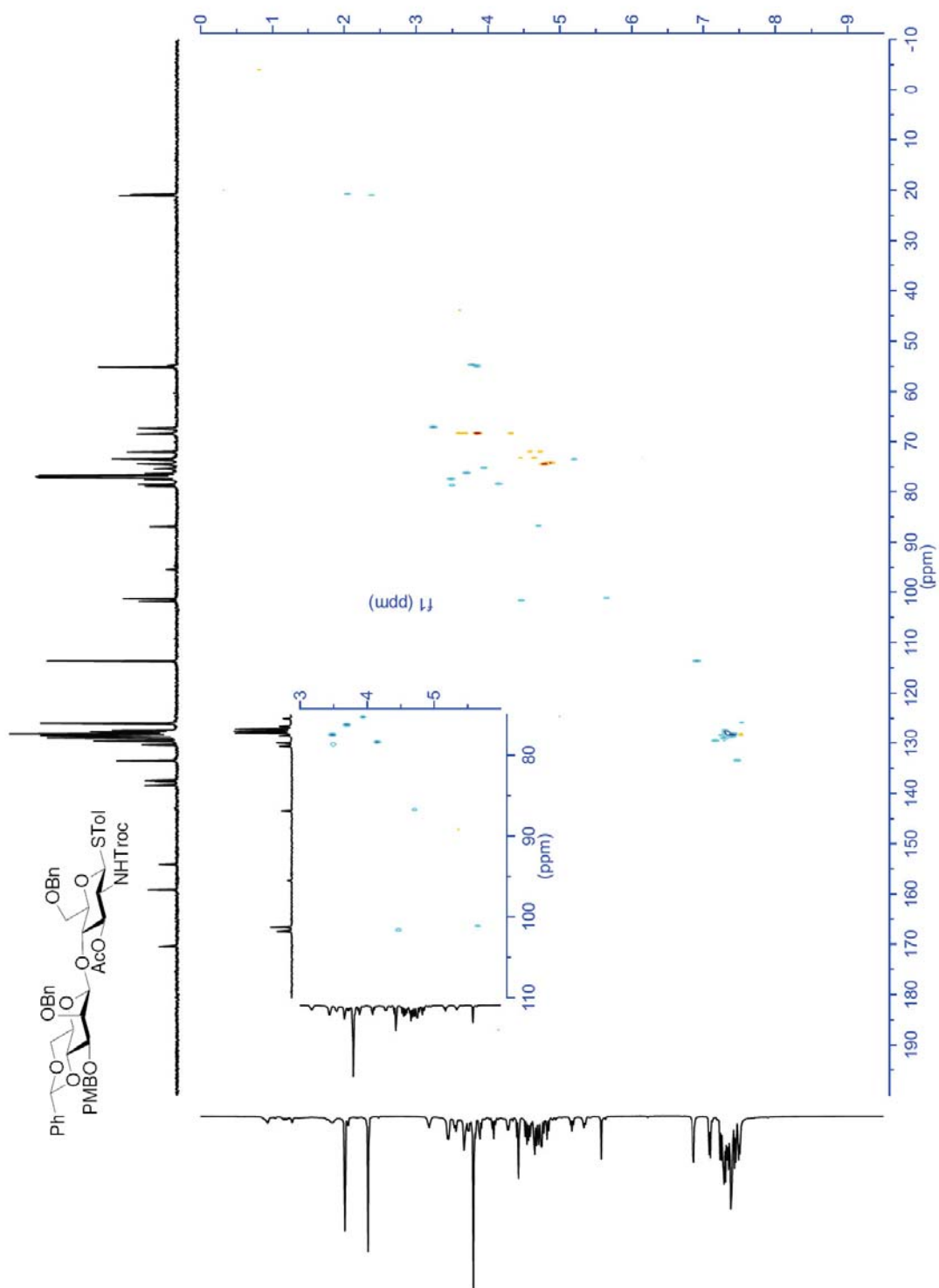

Gated decoupling ^{13}C NMR spectrum of tolyl 3-*O*-acetyl-6-*O*-benzyl-2-deoxy-4-*O*-(2-*O*-benzyl-4,6-*O*-benzylidene-3-*O*-*p*-methoxybenzyl- β -D-mannopyranosyl)-2-(trichloroethyloxycarbonyl)-1-thio- β -D-glucopyranoside **3**

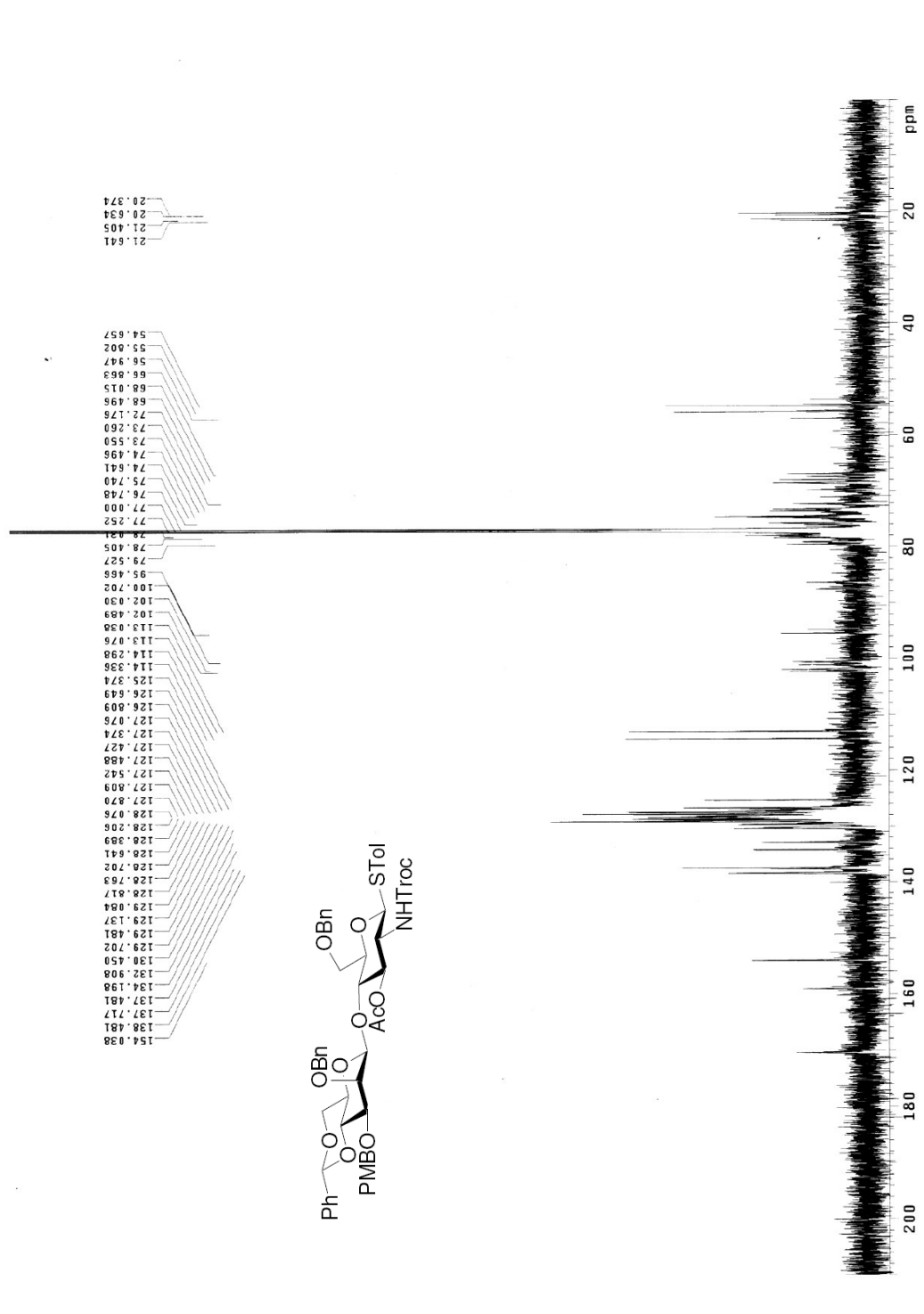

¹H NMR spectrum of tolyl 2-*O*-benzyl-4,6-*O*-benzylidene-3-*O*-*p*-methoxybenzyl-1-thio- α -D-mannopyranoside **4**

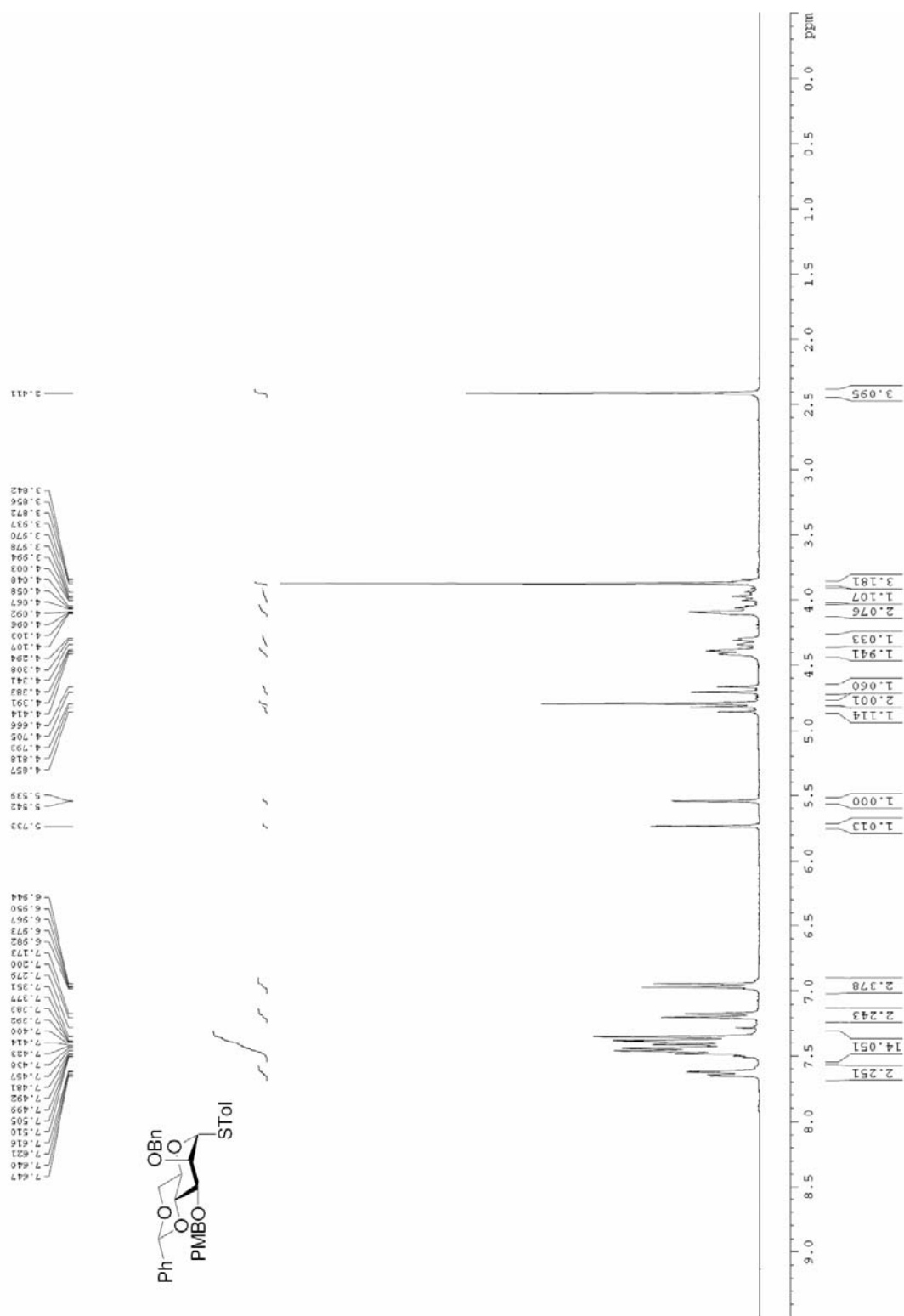

^{13}C NMR spectrum of tolyl 2-*O*-benzyl-4,6-*O*-benzylidene-3-*O*-*p*-methoxybenzyl-1-thio- α -D-mannopyranoside **4**

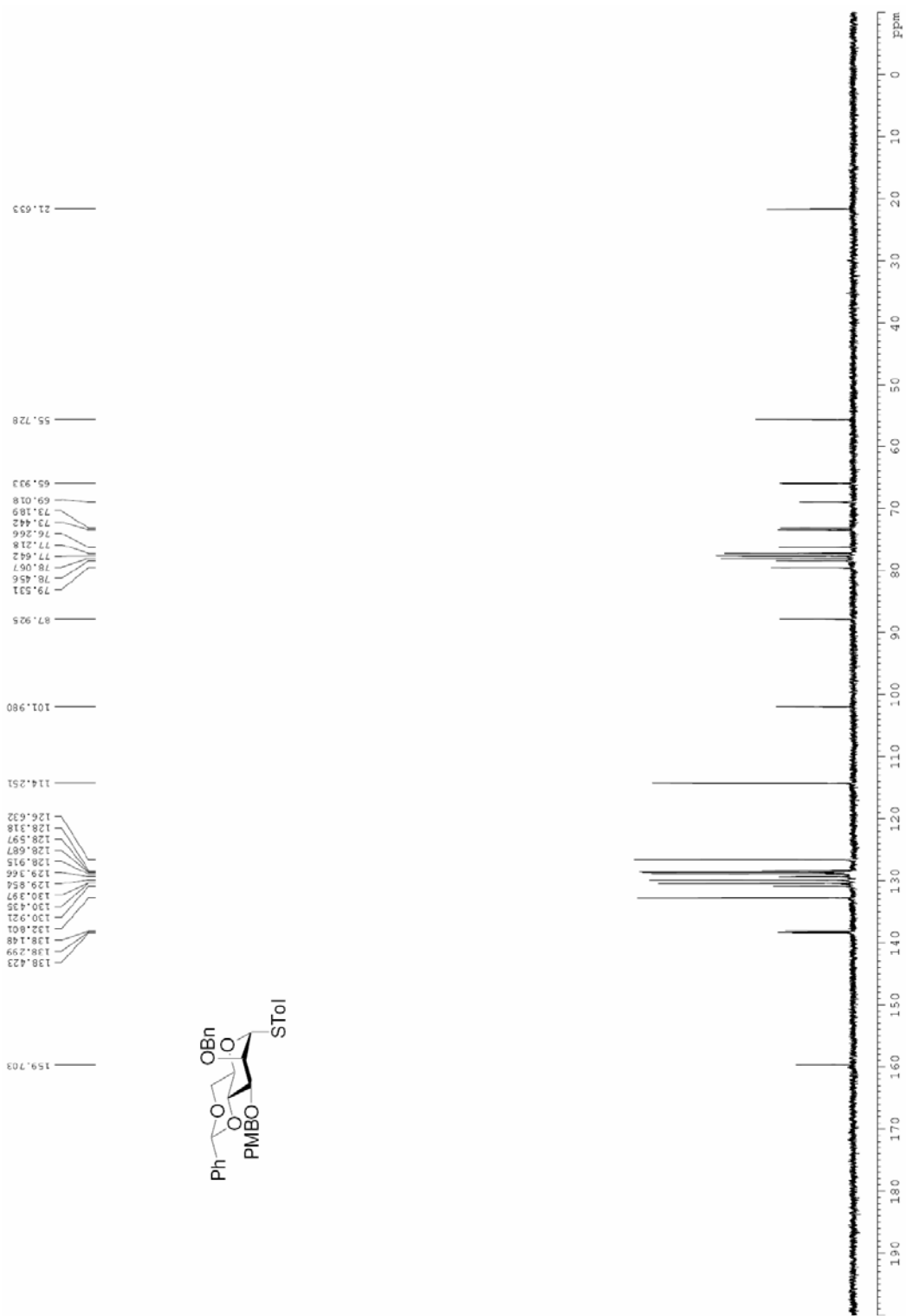

¹H NMR spectrum of 6-chlorohexyl 2-azido-3,6-di-O-benzyl-2-deoxy-β-D-glucopyranoside **5**

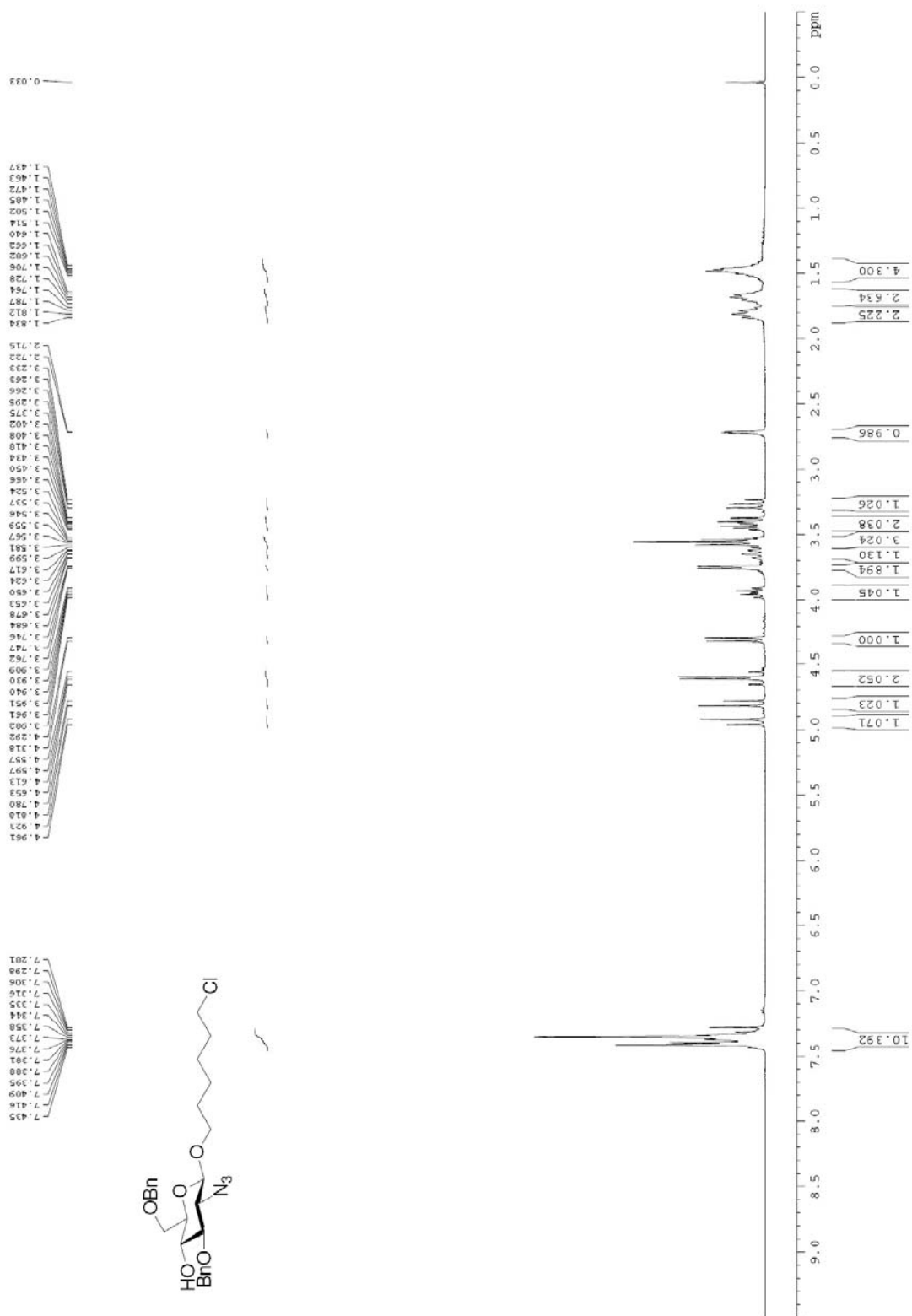

^{13}C NMR spectrum of 6-chlorohexyl 2-azido-3,6-di-*O*-benzyl-2-deoxy- β -D-glucopyranoside **5**

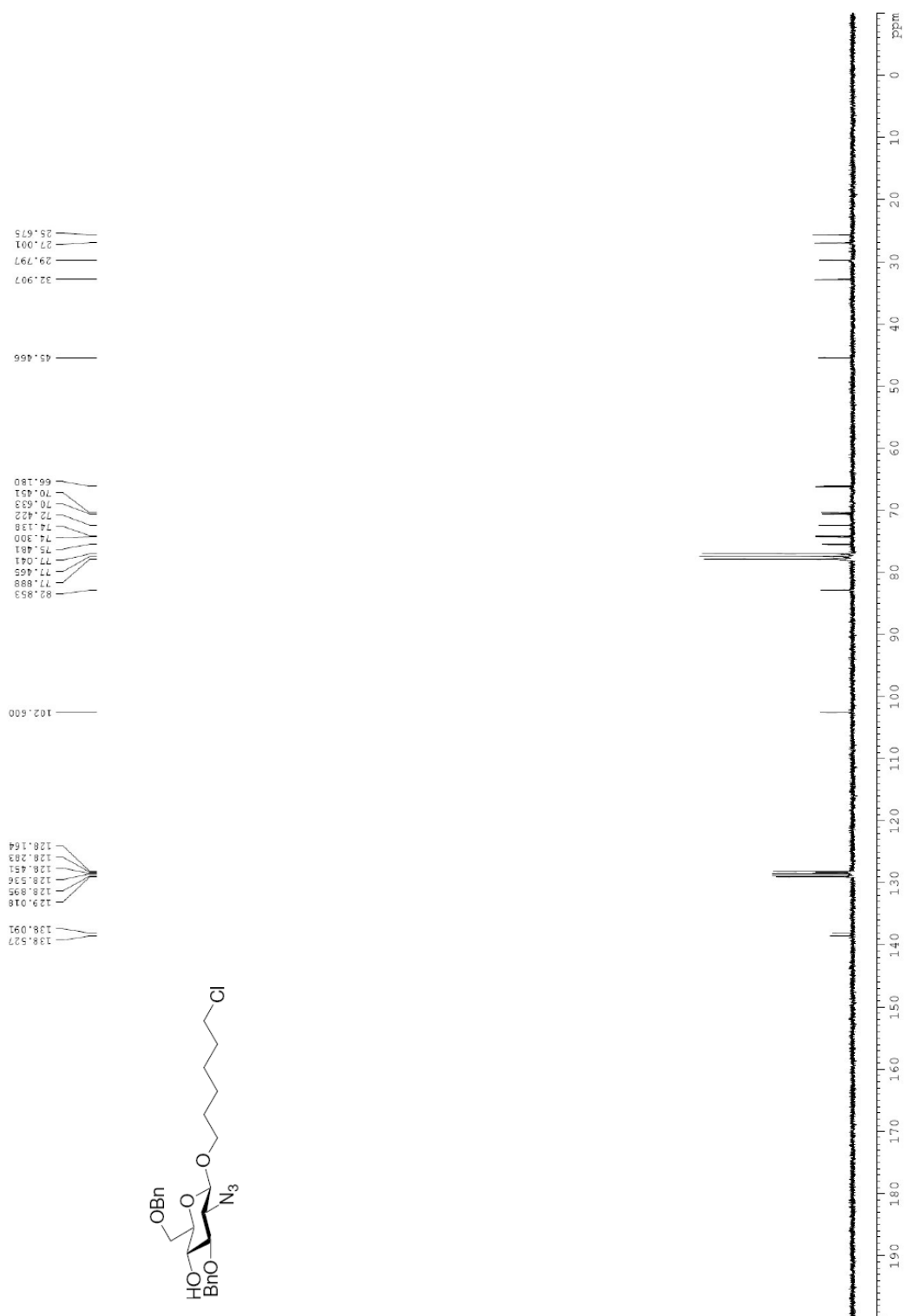

¹H NMR spectrum of 6-chlorohexyl 3,6-di-*O*-benzyl-2-azido-2-deoxy-4-*O*-[3-*O*-acetyl-6-*O*-benzyl-2-(trichloroethyloxycarbonyl)-4-*O*-(2-*O*-benzyl-4,6-*O*-benzylidene-3-*O*-*p*-methoxybenzyl-β-D-mannopyranosyl)-β-D-glucopyranosyl]-β-D-glucopyranoside **6**

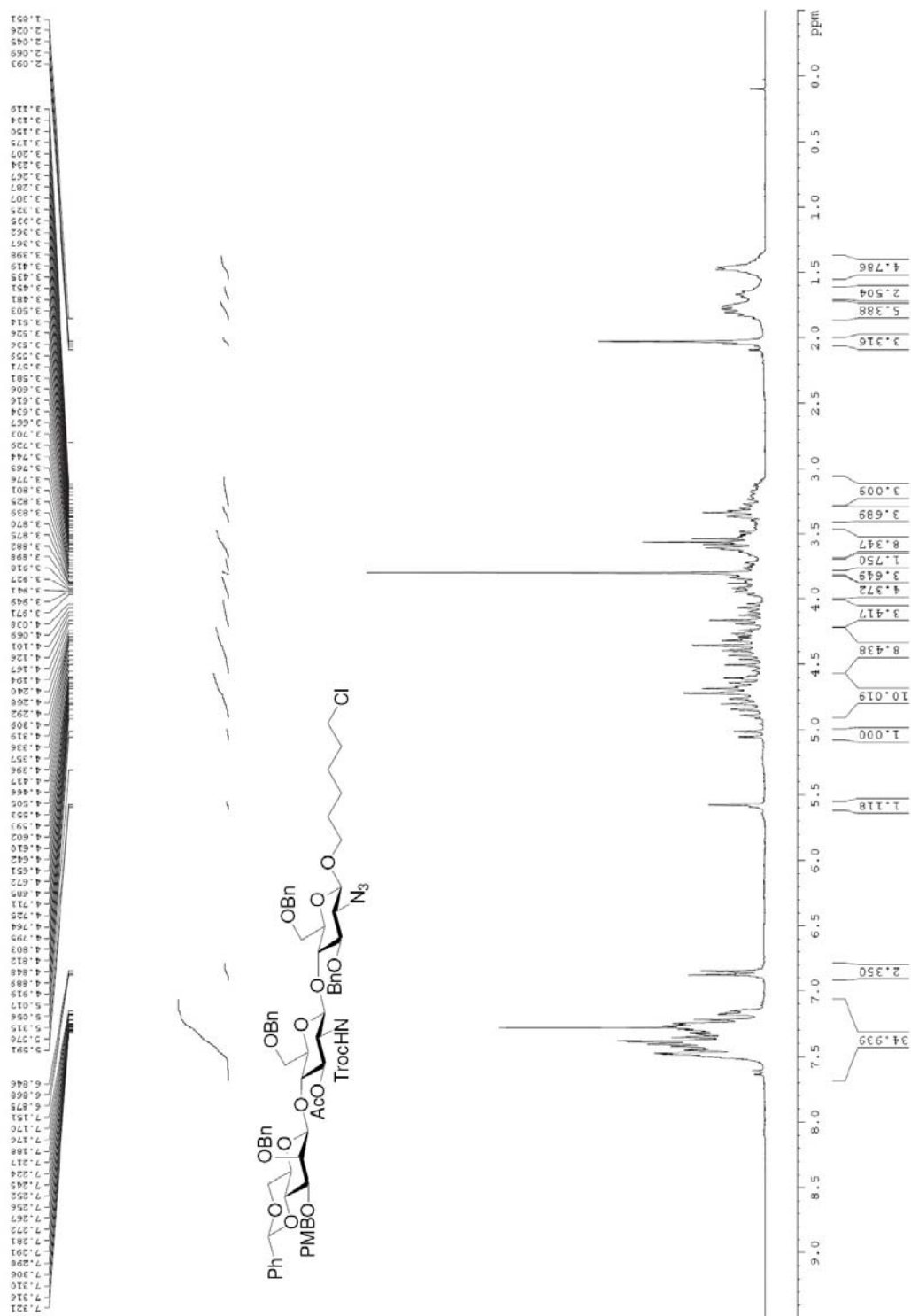

^1H NMR spectrum of tolyl 2,3-*O*-isopropylidene-1-thio- α -L-rhamnopyranoside **8**

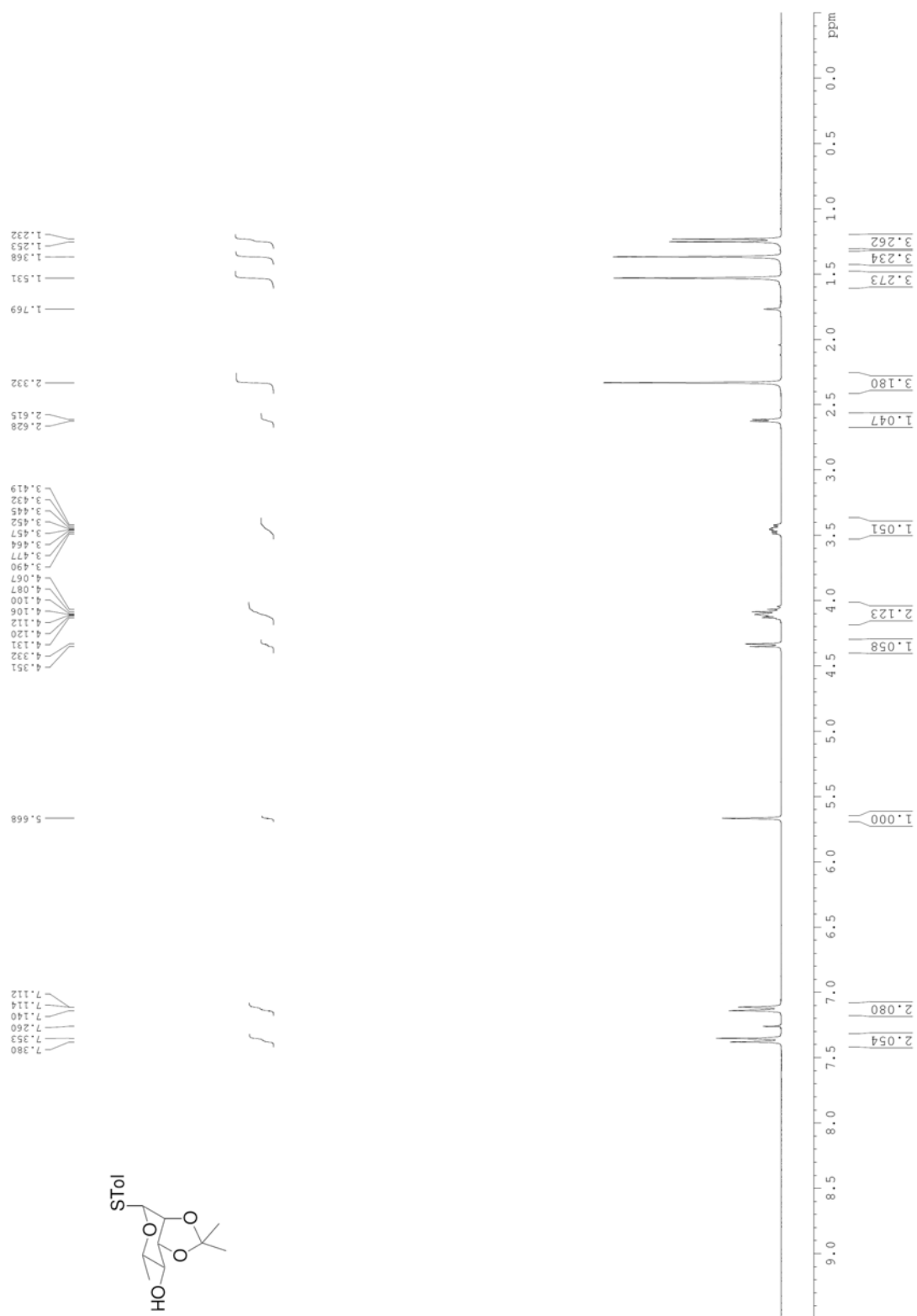

^{13}C NMR spectrum of tolyl 2,3-*O*-isopropylidene-1-thio- α -L-rhamnopyranoside **8**



^1H NMR spectrum of 3-chloropropyl 2-*O*-benzyl-4,6-*O*-benzylidene- β -D-galactopyranoside **9**

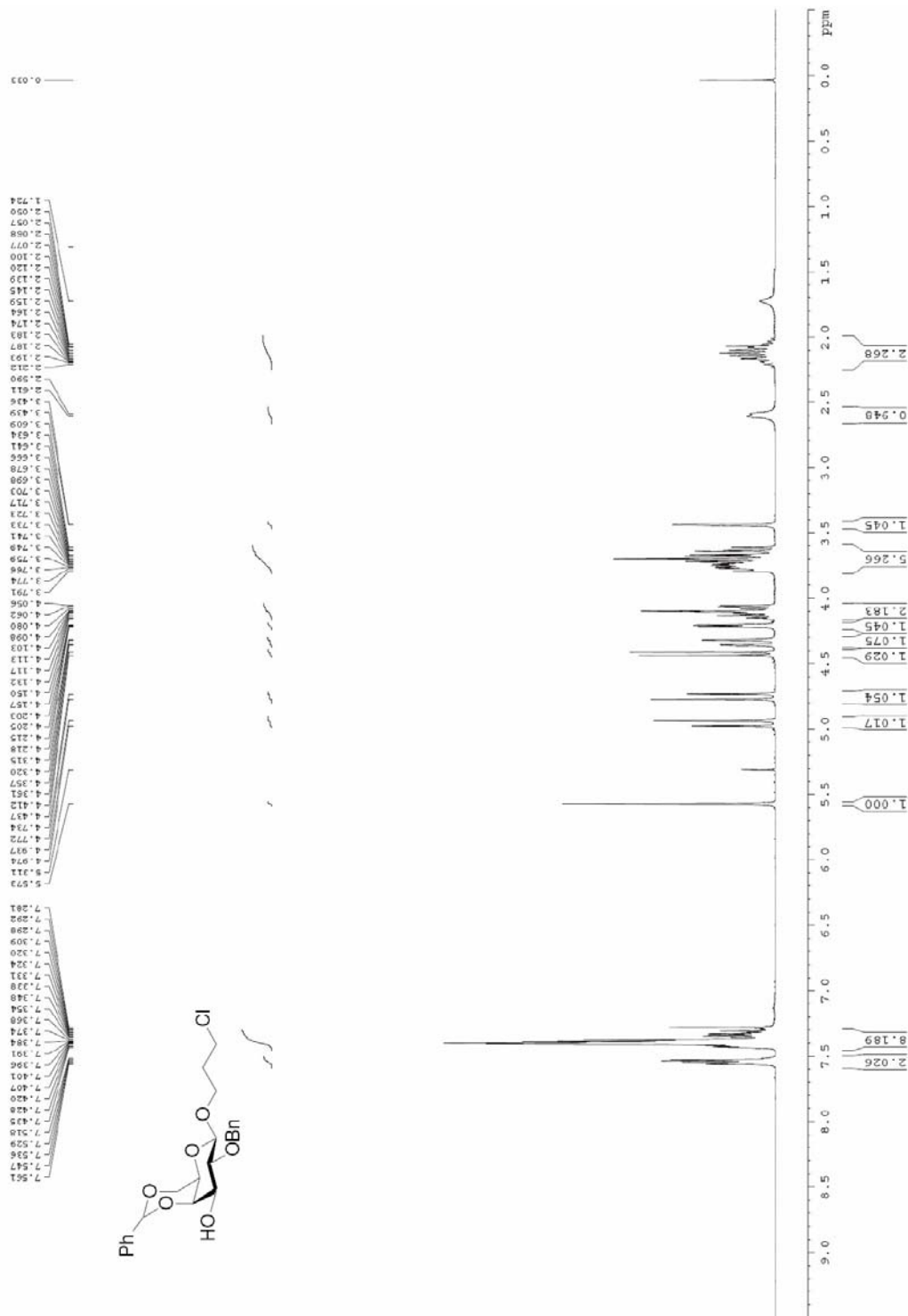

^{13}C NMR spectrum of 3-chloropropyl 2-*O*-benzyl-4,6-*O*-benzylidene- β -D-galactopyranoside **9**

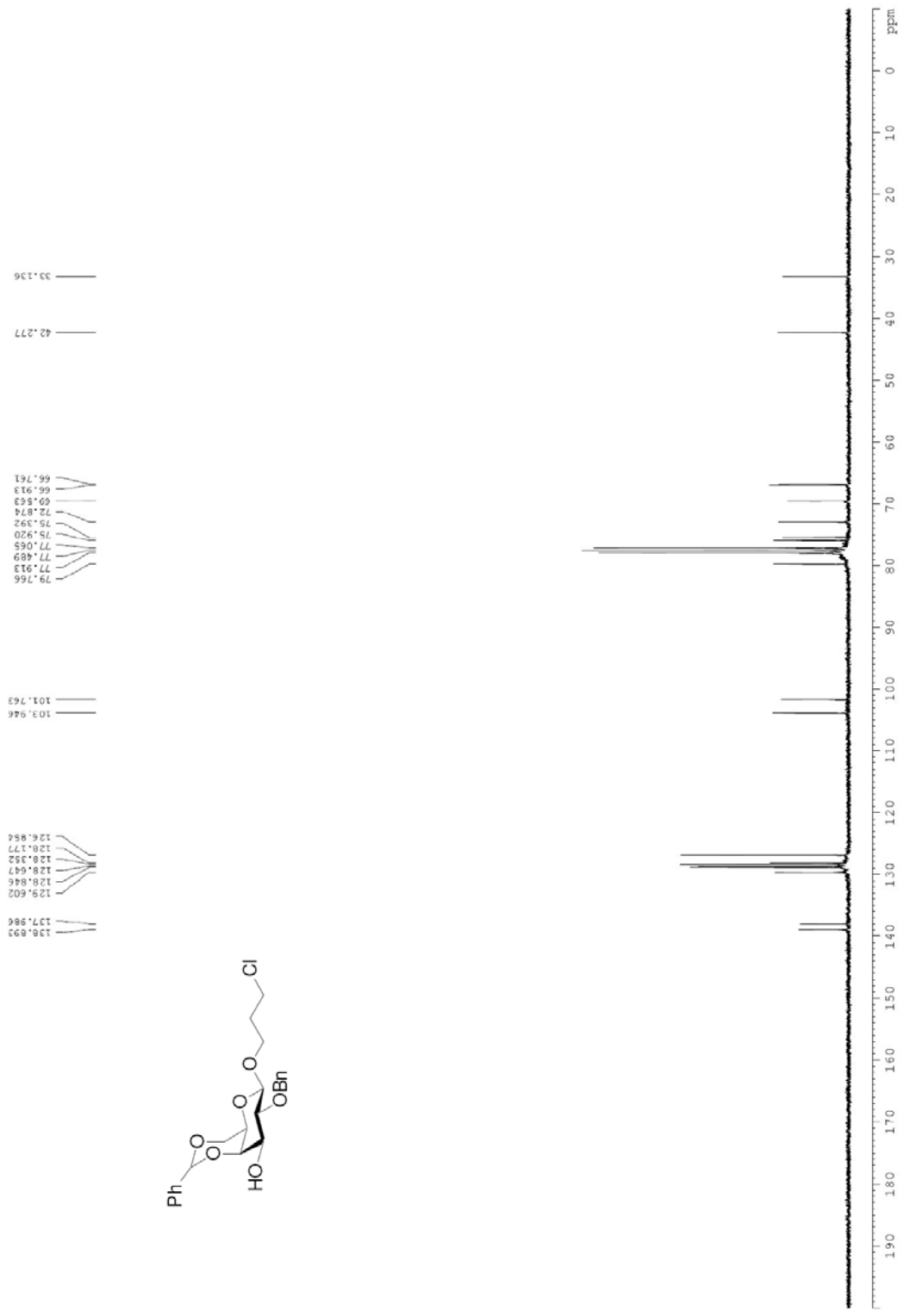

COSY NMR spectrum of 3-chloropropyl 2-*O*-benzyl-4,6-*O*-benzylidene- β -D-galactopyranoside **9**

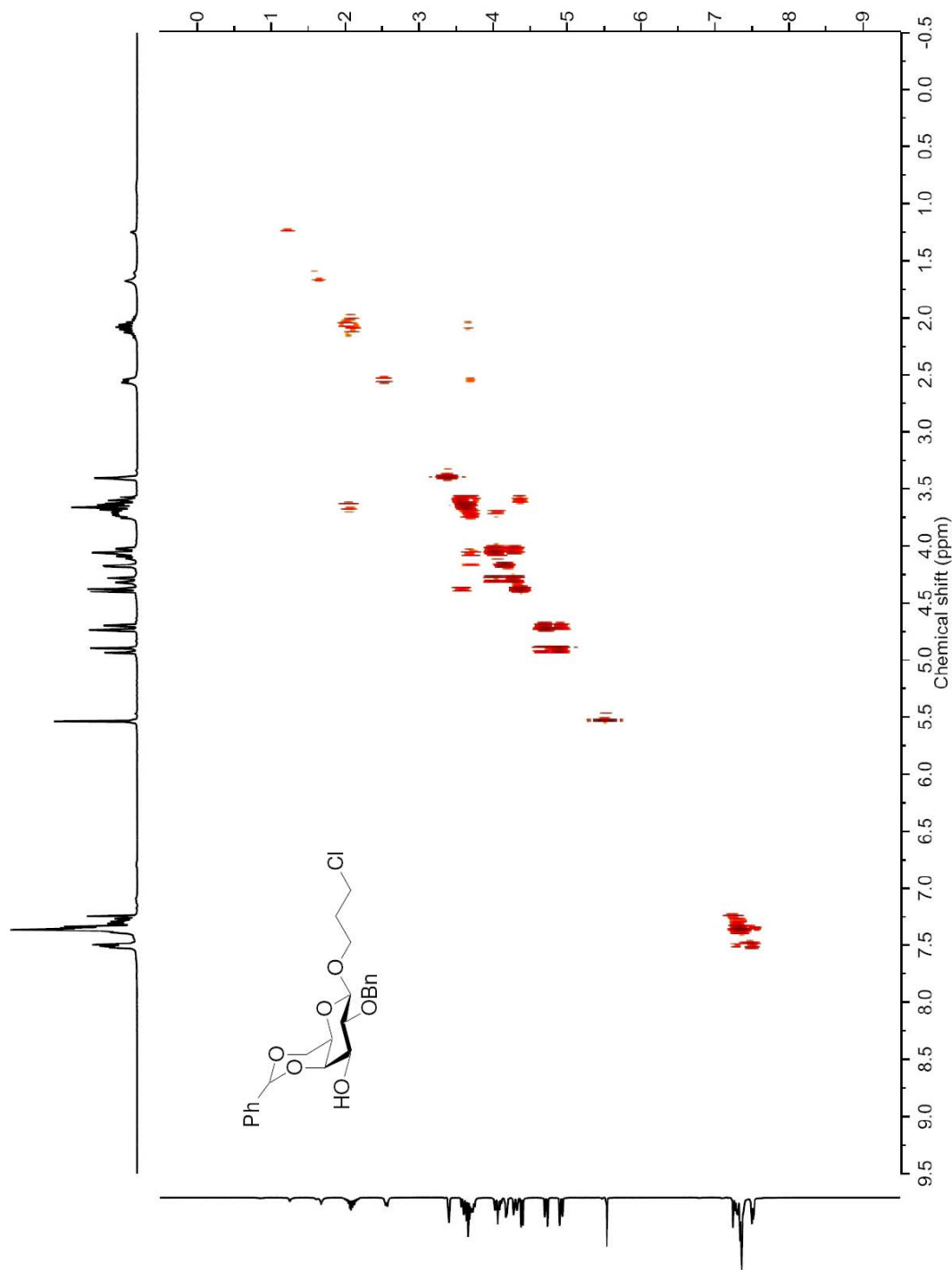

HMQC NMR spectrum of 3-chloropropyl 2-*O*-benzyl-4,6-*O*-benzylidene- β -D-galactopyranoside **9**

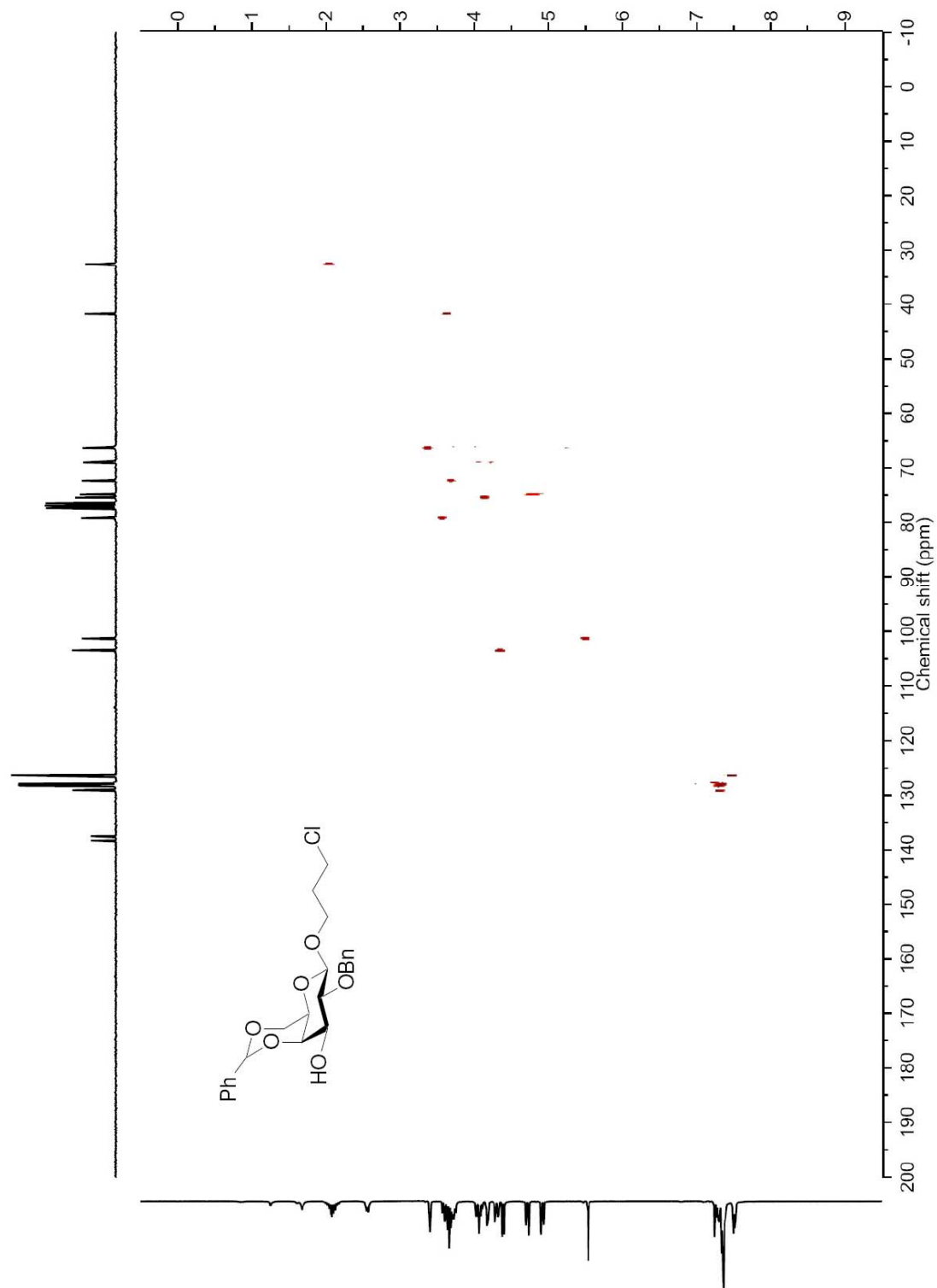

Non-decoupling ^{13}C NMR spectrum of 3-chloropropyl 2-*O*-benzyl-4,6-*O*-benzylidene- β -D-galactopyranoside **9**

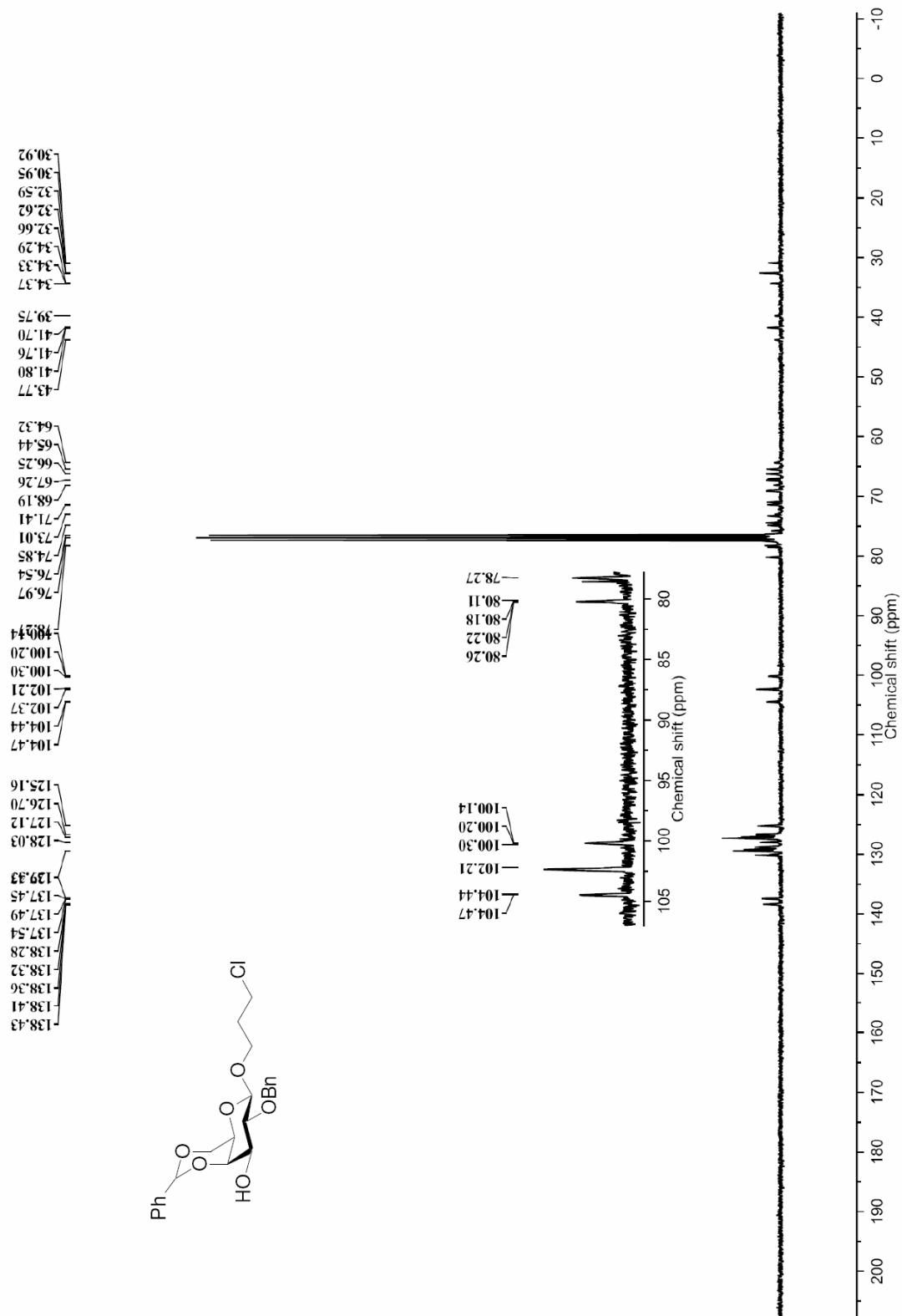

¹H NMR spectrum of (3-chloropropyl) 2-*O*-benzyl-4,6-*O*-benzylidene-3-*O*-[2,3-*O*-isopropylidene-4-*O*-(2,3-di-*O*-benzyl-4,6-*O*-benzylidene-β-D-mannopyranosyl)-α-L-rhamnopyranoside]-β-D-galactopyranoside **10**

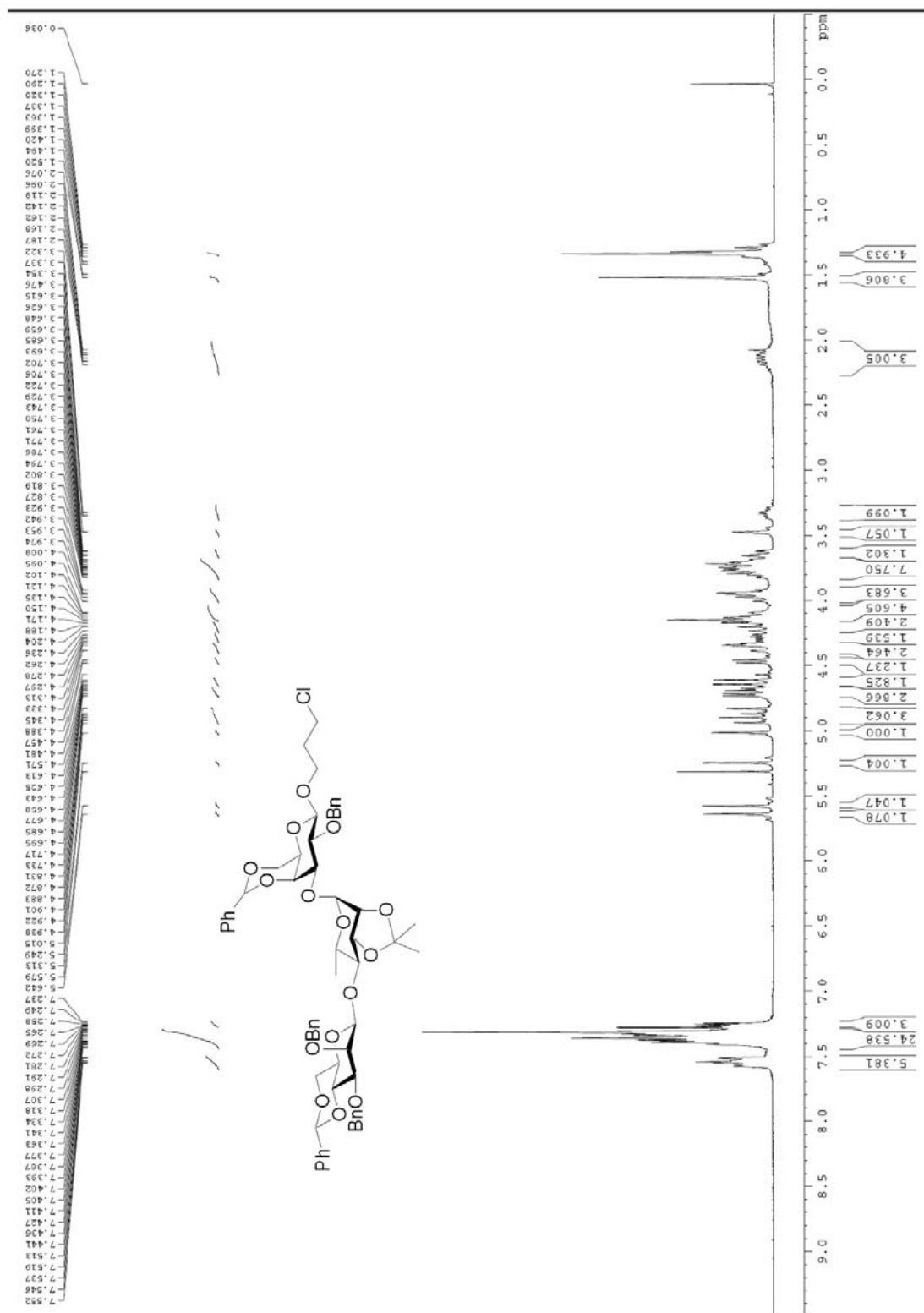

^{13}C NMR spectrum of (3-chloropropyl) 2-*O*-benzyl-4,6-*O*-benzylidene-3-*O*-[2,3-*O*-isopropylidene-4-*O*-(2,3-di-*O*-benzyl-4,6-*O*-benzylidene- β -D-mannopyranosyl)- α -L-rhamnopyranoside]- β -D-galactopyranoside **10**

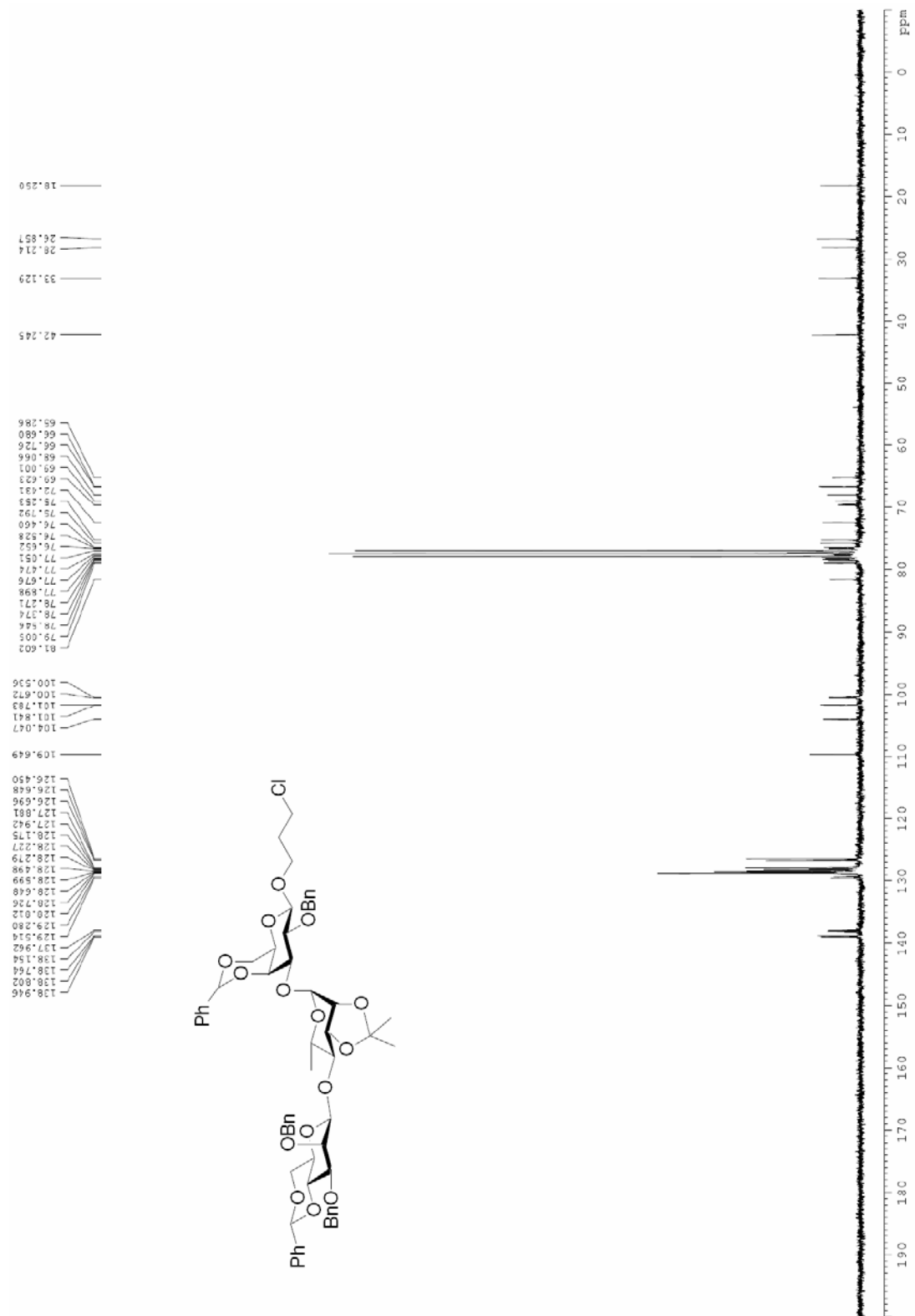

COSY NMR spectrum of (3-chloropropyl) 2-*O*-benzyl-4,6-*O*-benzylidene-3-*O*-[2,3-*O*-isopropylidene-4-*O*-(2,3-di-*O*-benzyl-4,6-*O*-benzylidene- β -D-mannopyranosyl)- α -L-rhamnopyranoside]- β -D-galactopyranoside **10**

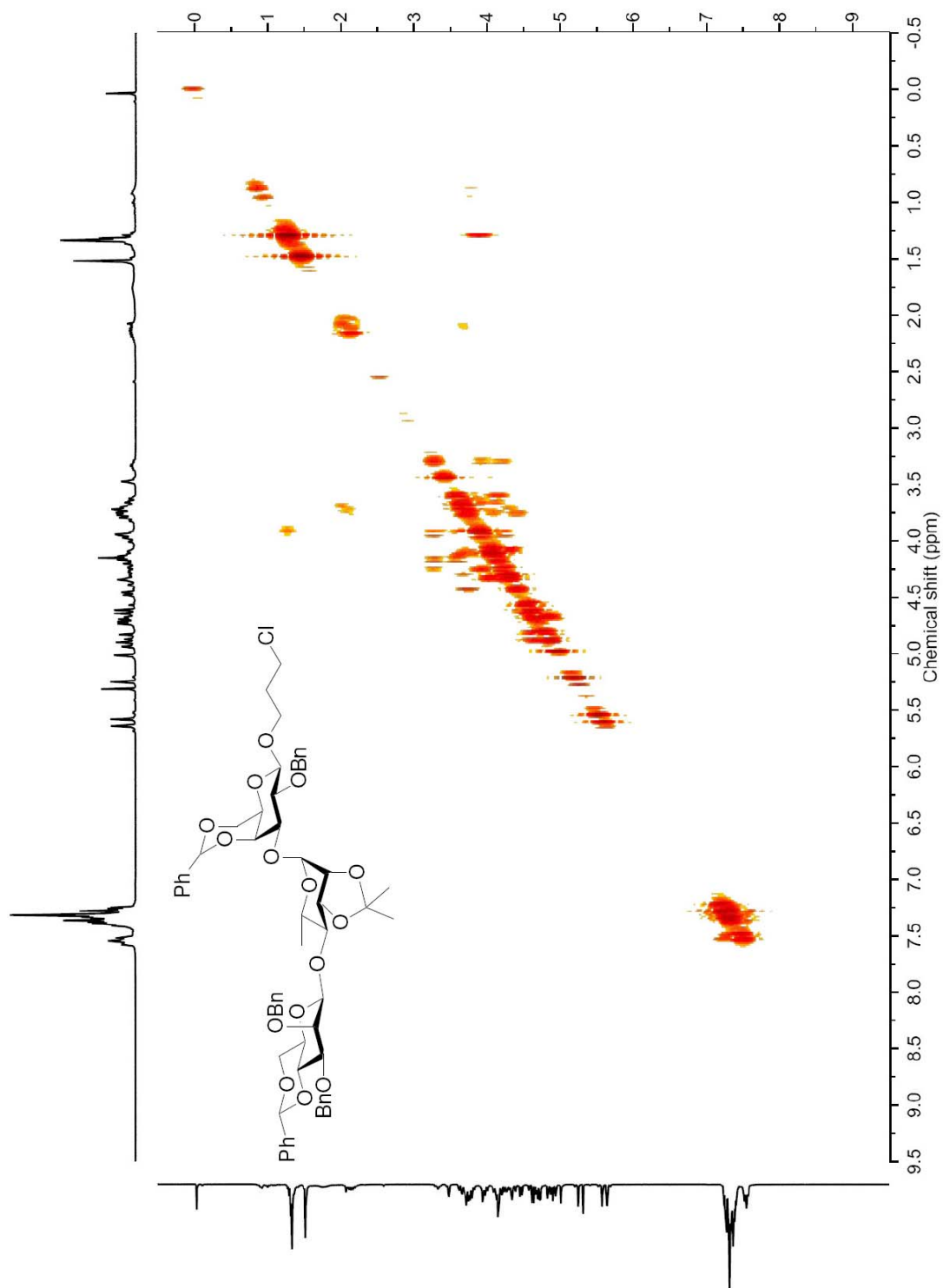

HMQC NMR spectrum of (3-chloropropyl) 2-*O*-benzyl-4,6-*O*-benzylidene-3-*O*-[2,3-*O*-isopropylidene-4-*O*-(2,3-di-*O*-benzyl-4,6-*O*-benzylidene- β -D-mannopyranosyl)- α -L-rhamnopyranoside]- β -D-galactopyranoside **10**

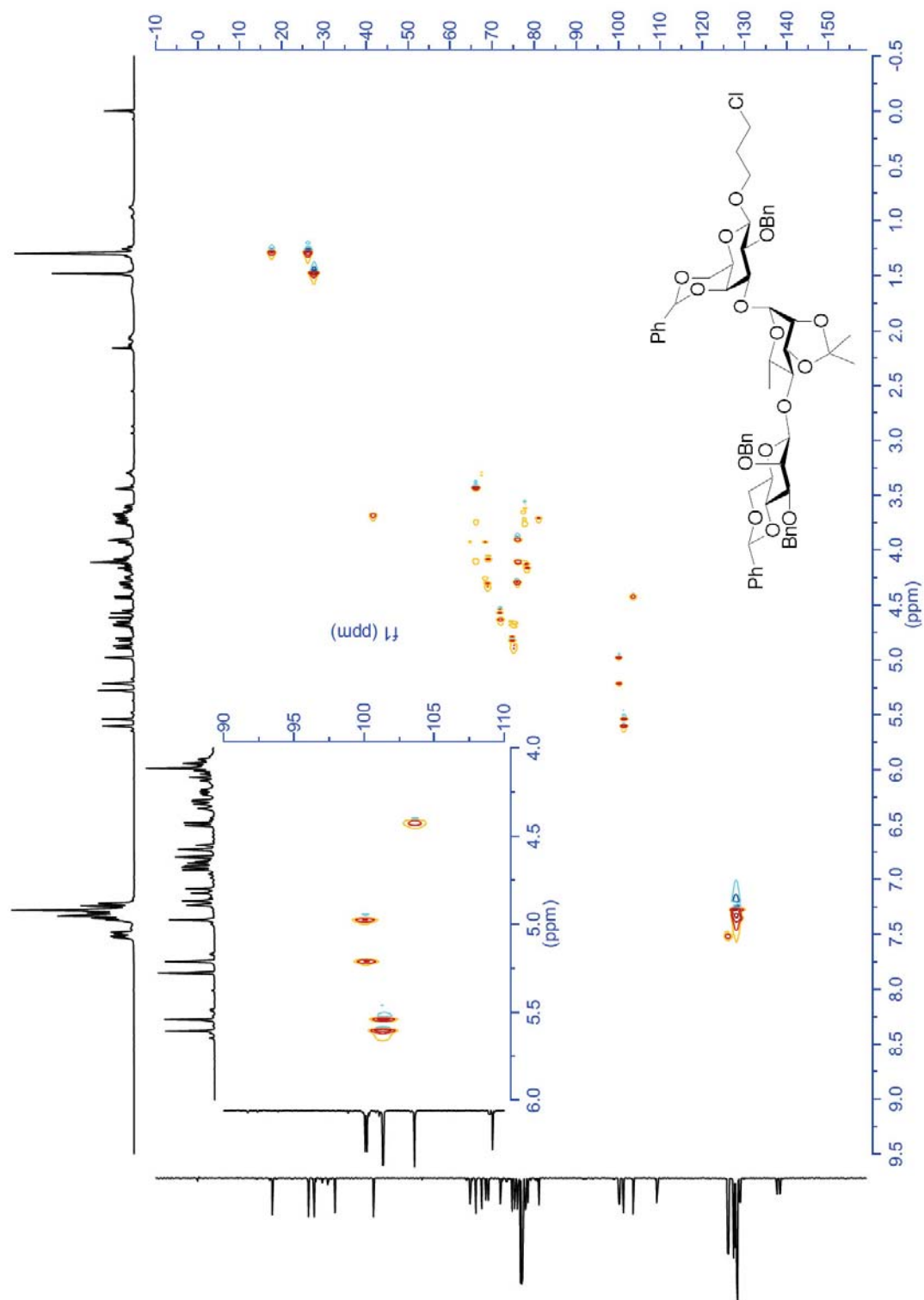

Gated decoupling C^{13} NMR spectrum of (3-chloropropyl) 2-*O*-benzyl-4,6-*O*-benzylidene-3-*O*-2,3-*O*-isopropylidene-4-*O*-(2,3-di-*O*-benzyl-4,6-*O*-benzylidene- β -D-mannopyranosyl)- α -L-rhamnopyranoside]- β -D-galactopyranoside **10**

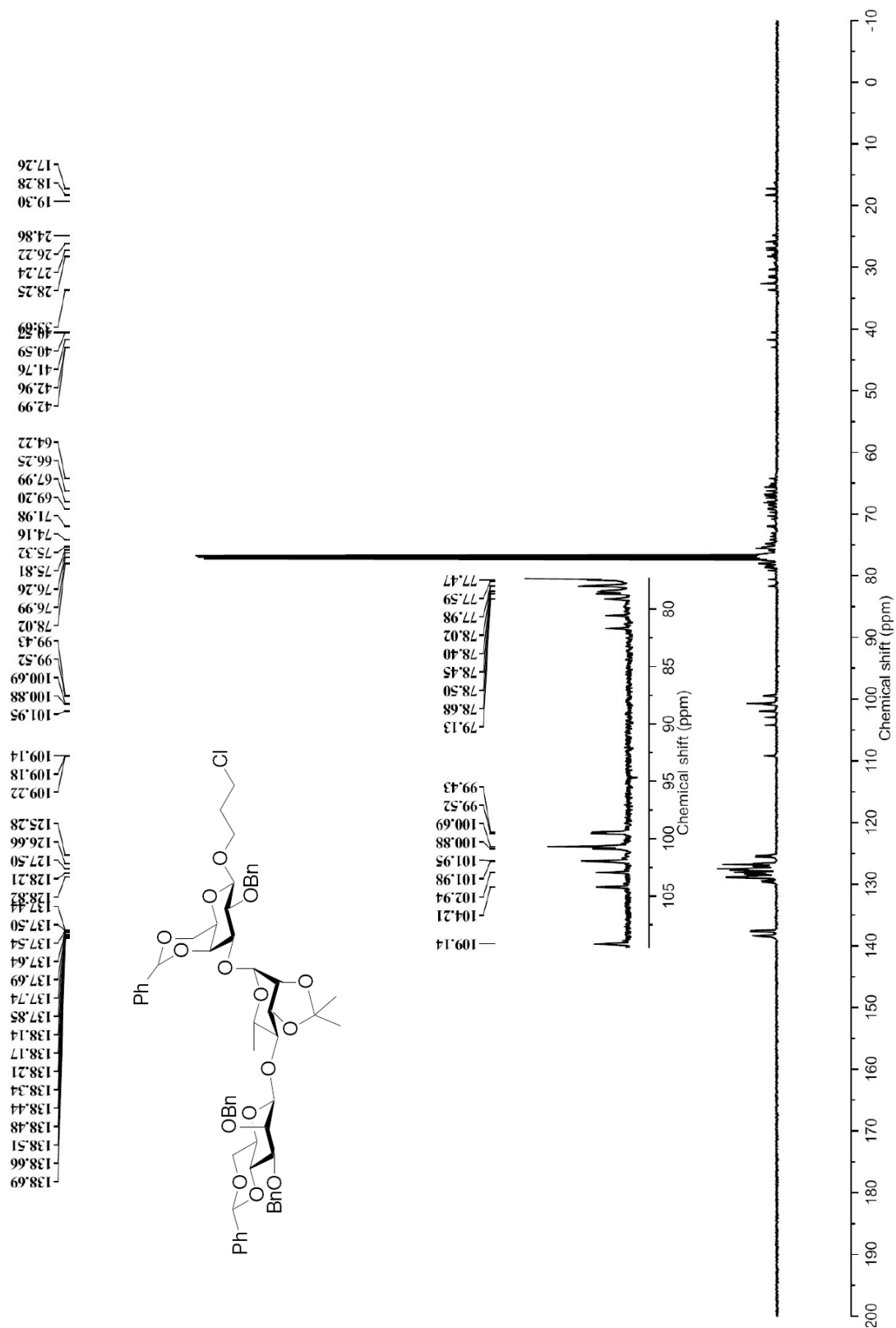

^1H NMR spectrum of 2,3-di-*O*-benzyl-4,6-*O*-benzylidene- α -D-mannopyranosyl trichloroacetimidate **11**

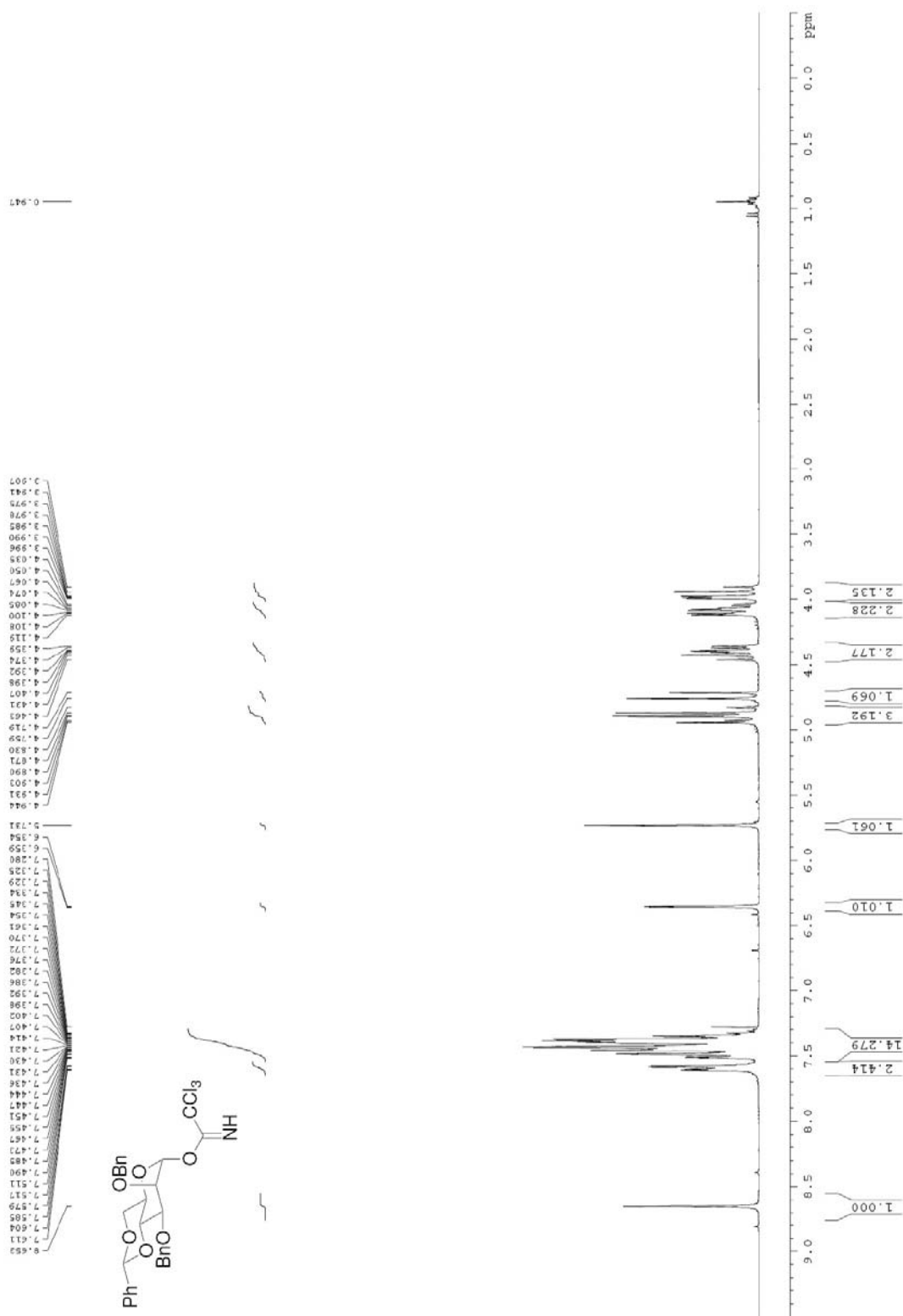

^{13}C NMR spectrum of 2,3-di-*O*-benzyl-4,6-*O*-benzylidene- α -D-mannopyranosyl trichloroacetimidate **11**

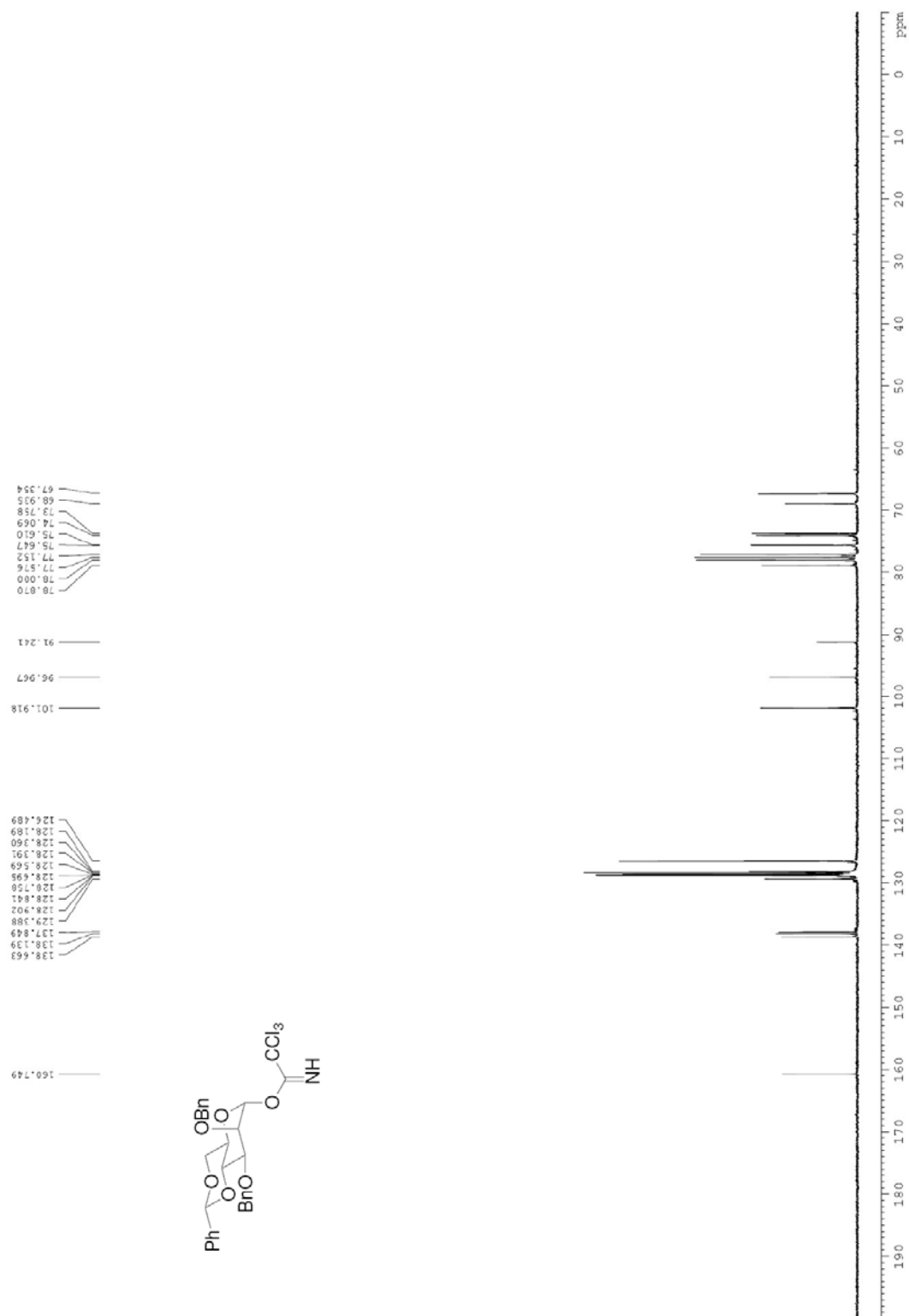

¹H NMR spectrum of (2,6-dimethylphenyl) 2-azido-3,6-di-*O*-benzyl-2-deoxy-1-thio-β-D-glucopyranoside **12**

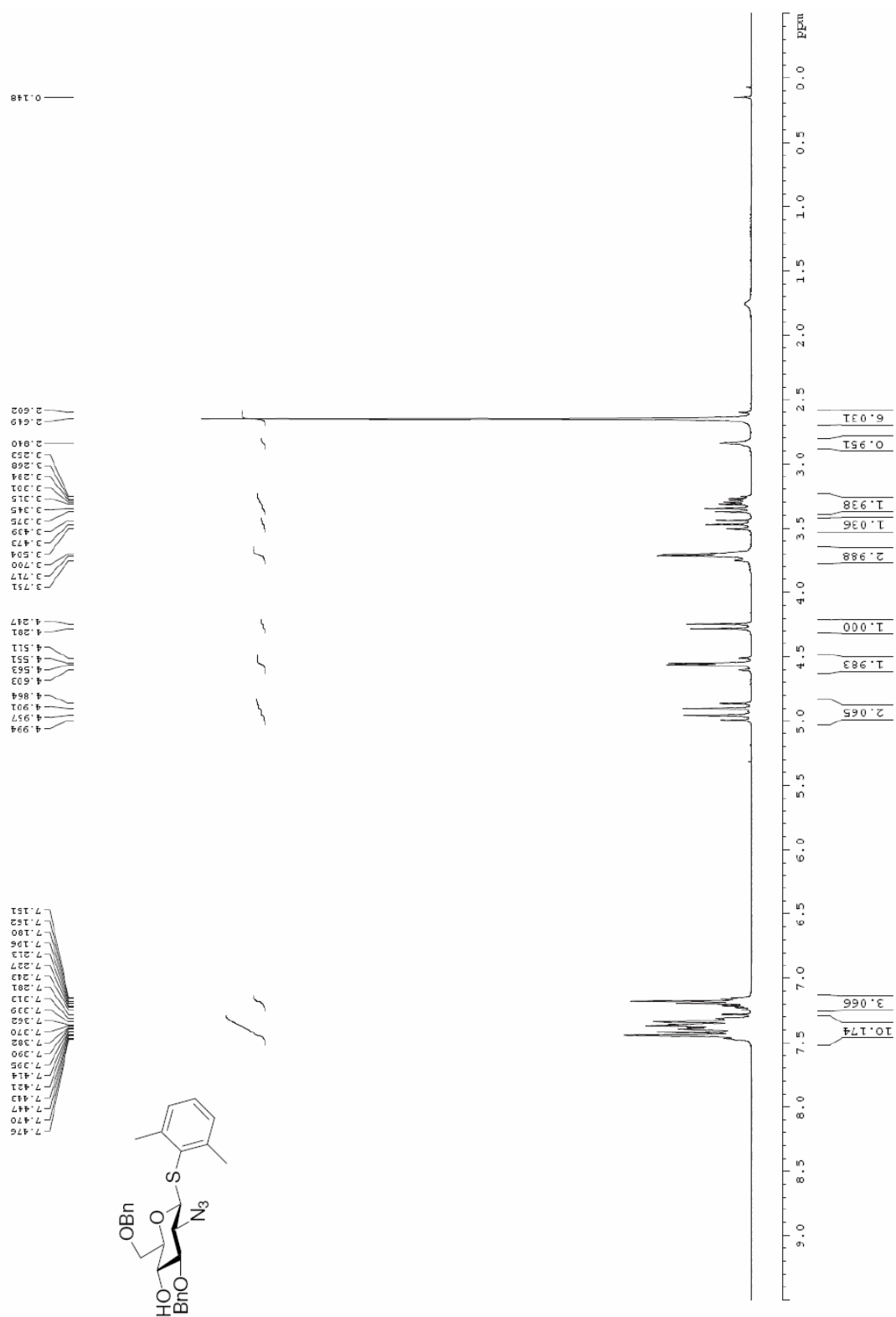

^{13}C NMR spectrum of (2,6-dimethylphenyl) 2-azido-3,6-di-*O*-benzyl-2-deoxy-1-thio- β -D-glucopyranoside **12**

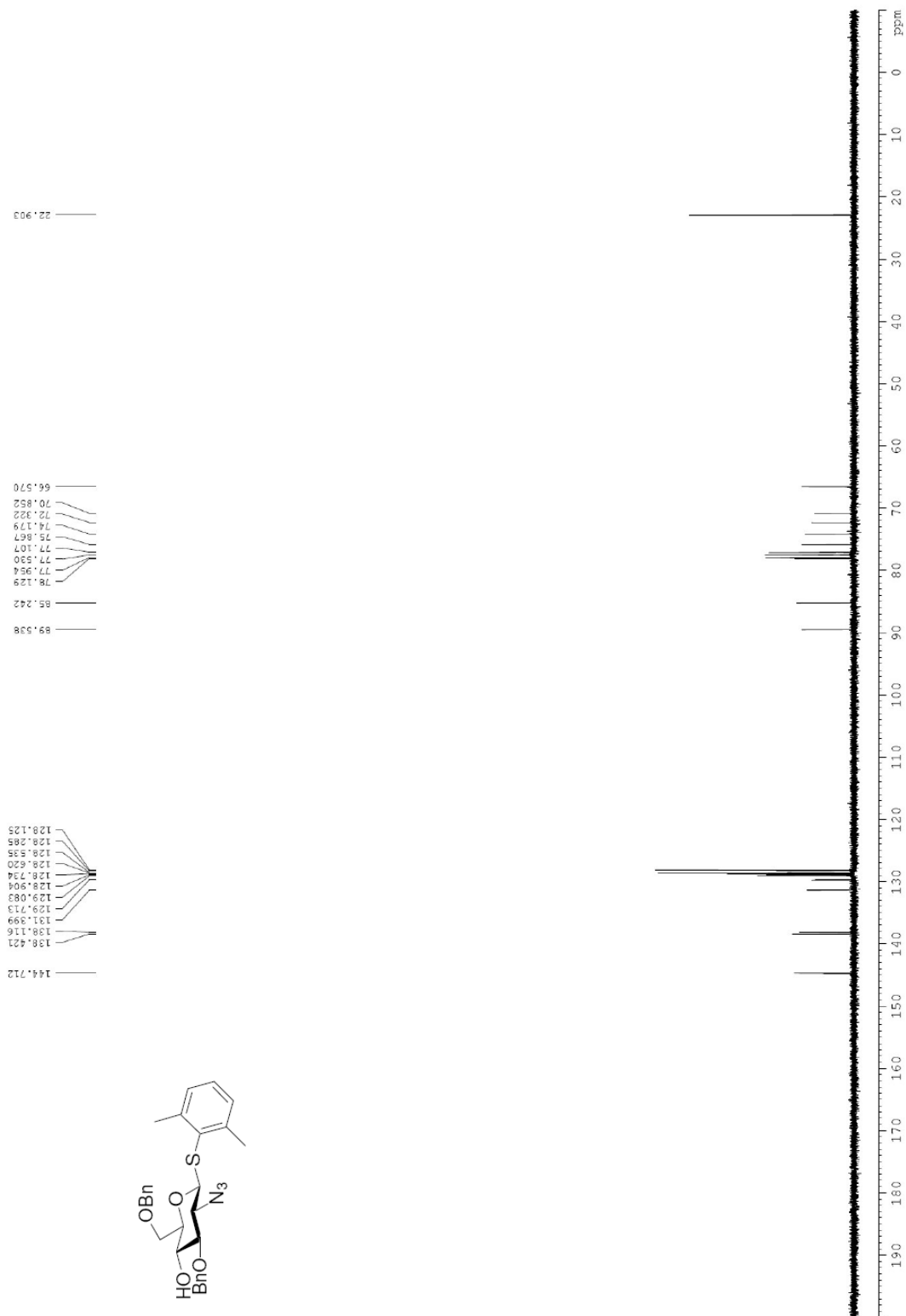

^1H NMR spectrum of (2,6-dimethylphenyl) 2-azido-3,6-di-*O*-benzyl-4-*O*-(2,3-di-*O*-benzyl-4,6-*O*-benzylidene-*D*-mannopyranosyl)-1-thio- β -*D*-glucopyranoside **13**

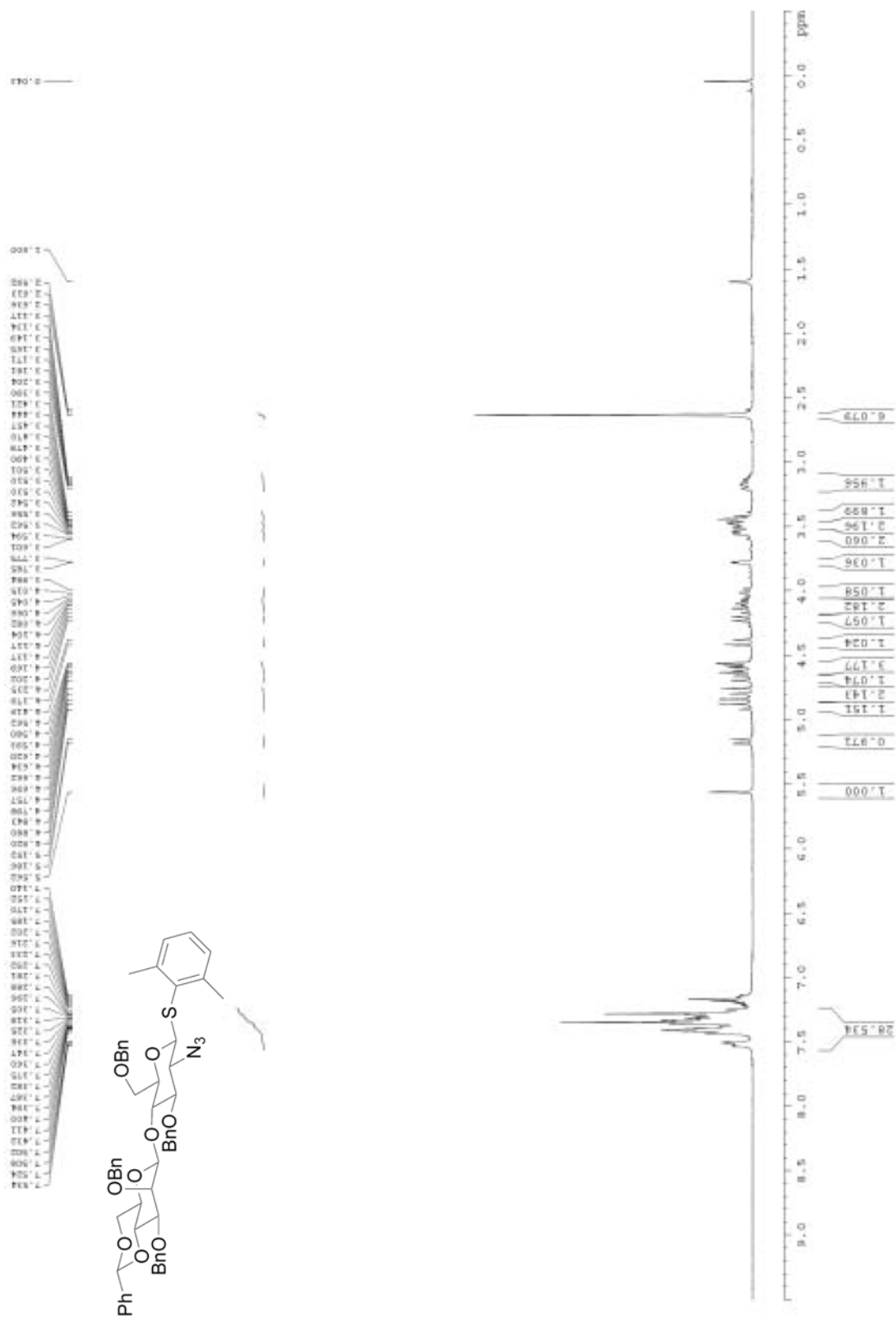

^{13}C NMR spectrum of (2,6-dimethylphenyl) 2-azido-3,6-di-*O*-benzyl-4-*O*-(2,3-di-*O*-benzyl-4,6-*O*-benzylidene-*D*-mannopyranosyl)-1-thio- β -*D*-glucopyranoside **13**

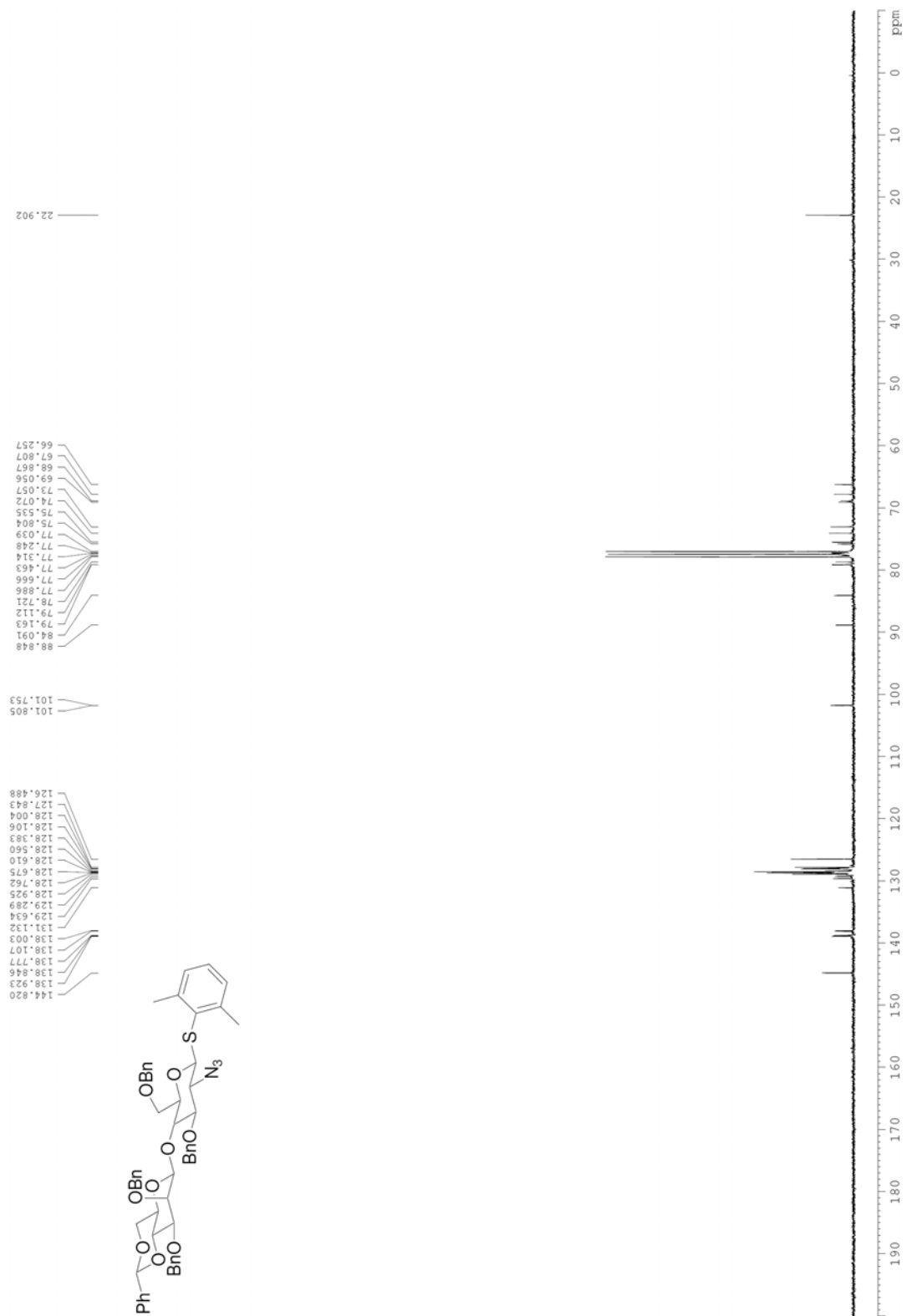

Non-decoupling ^{13}C NMR spectrum of (2,6-dimethylphenyl) 2-azido-3,6-di-*O*-benzyl-4-*O*-(2,3-di-*O*-benzyl-4,6-*O*-benzylidene-*D*-mannopyranosyl)-1-thio- β -*D*-glucopyranoside **13**

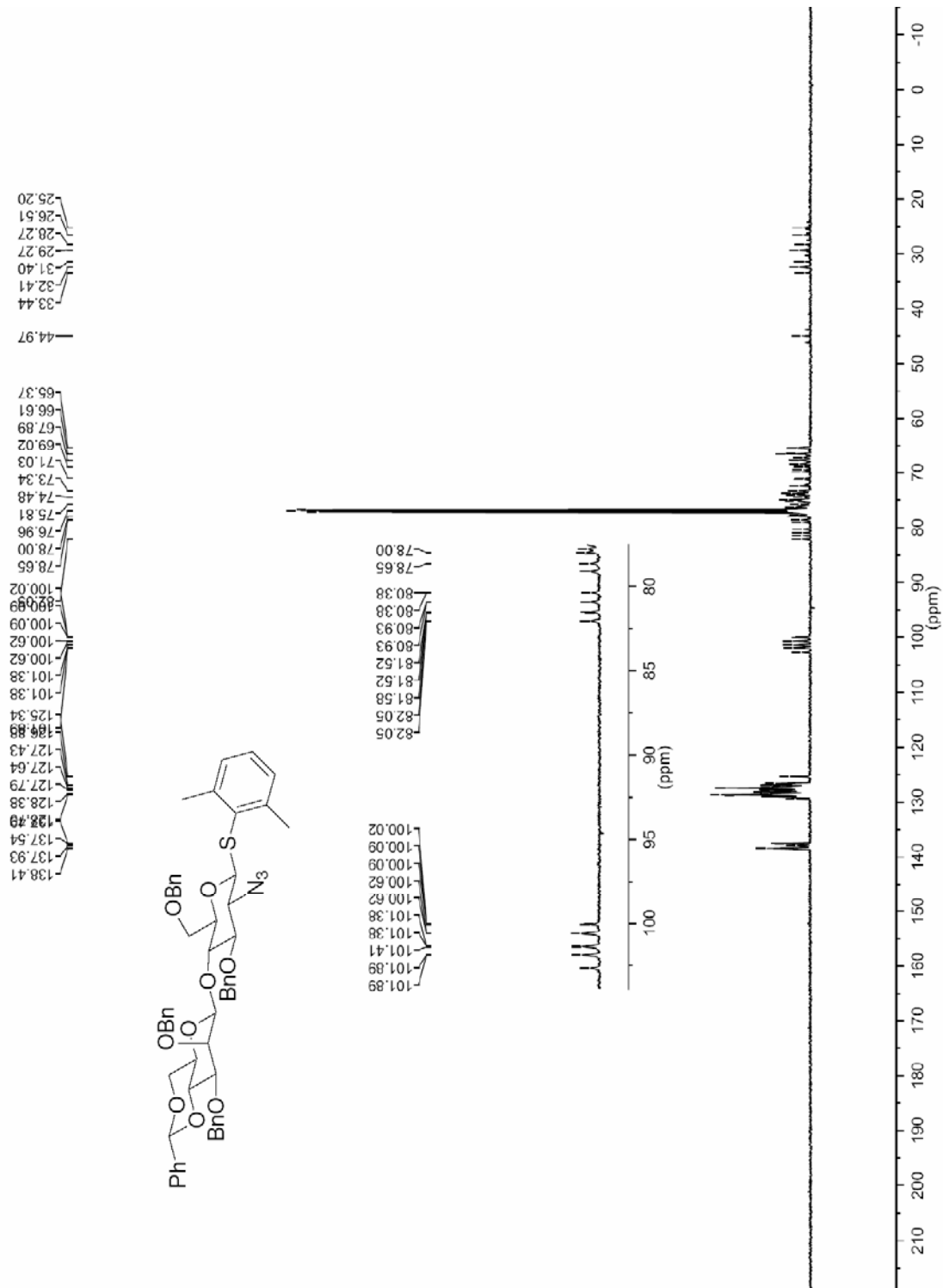

¹H NMR spectrum of (1-chlorohexyl) 2-azido-3,6-di-O-benzyl-2-deoxy-4-O-[2-azido-3,6-di-O-benzyl-4-O-(2,3-di-O-benzyl-4,6-O-benzylidene-β-D-mannopyranosyl)-β-D-glucopyranosyl]-β-D-glucopyranoside **14**

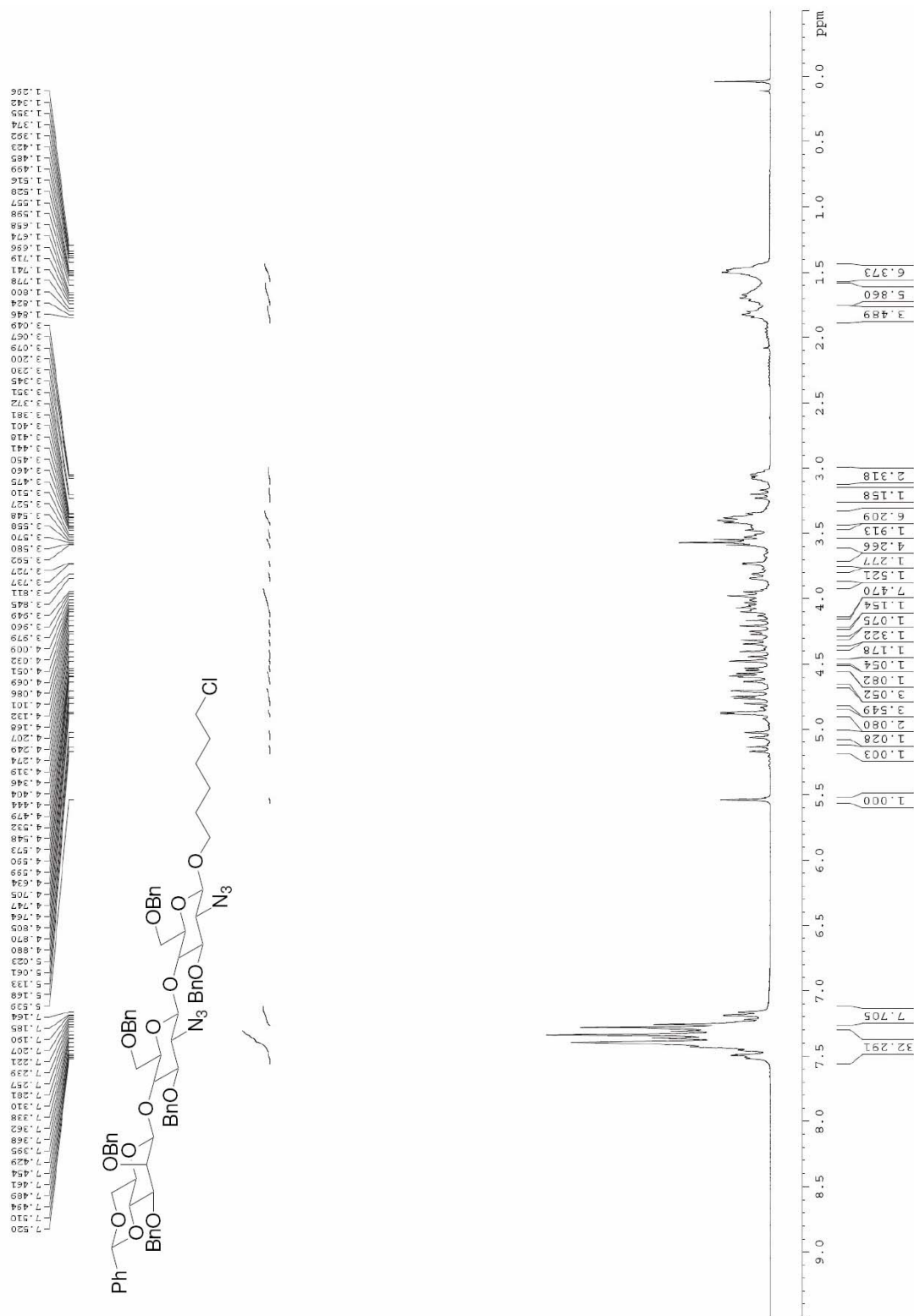

^{13}C NMR spectrum of (1-chlorohexyl) 2-azido-3,6-di-*O*-benzyl-2-deoxy-4-*O*-[2-azido-3,6-di-*O*-benzyl-4-*O*-(2,3-di-*O*-benzyl-4,6-*O*-benzylidene- β -D-mannopyranosyl)- β -D-glucopyranosyl]- β -D-glucopyranoside **14**

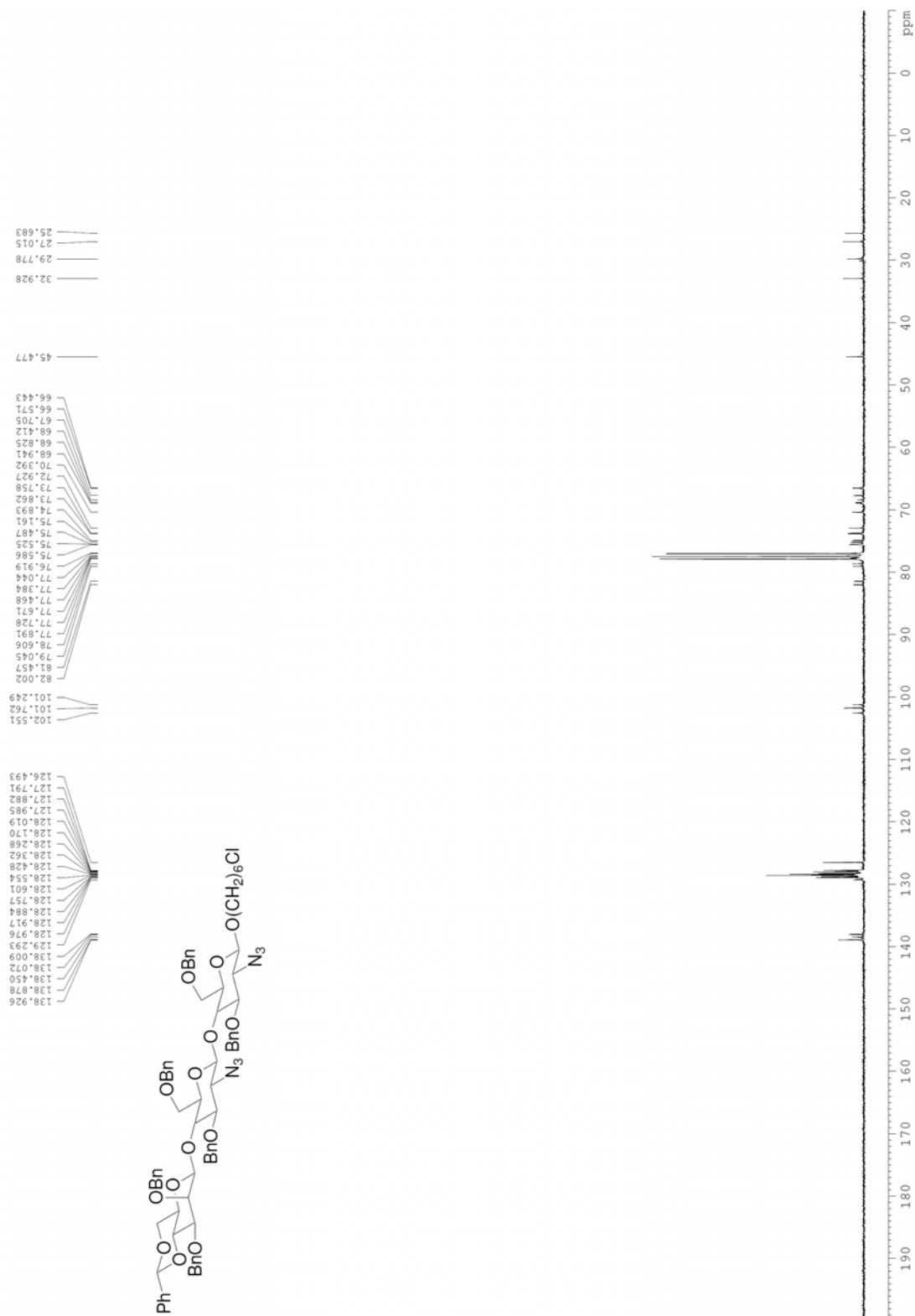

HMQC ^{13}C NMR spectrum of (1-chlorohexyl) 2-azido-3,6-di-*O*-benzyl-2-deoxy-4-*O*-[2-azido-3,6-di-*O*-benzyl-4-*O*-(2,3-di-*O*-benzyl-4,6-*O*-benzylidene- β -D-mannopyranosyl)- β -D-glucospyranosyl] - β -D-glucospyranoside **14**

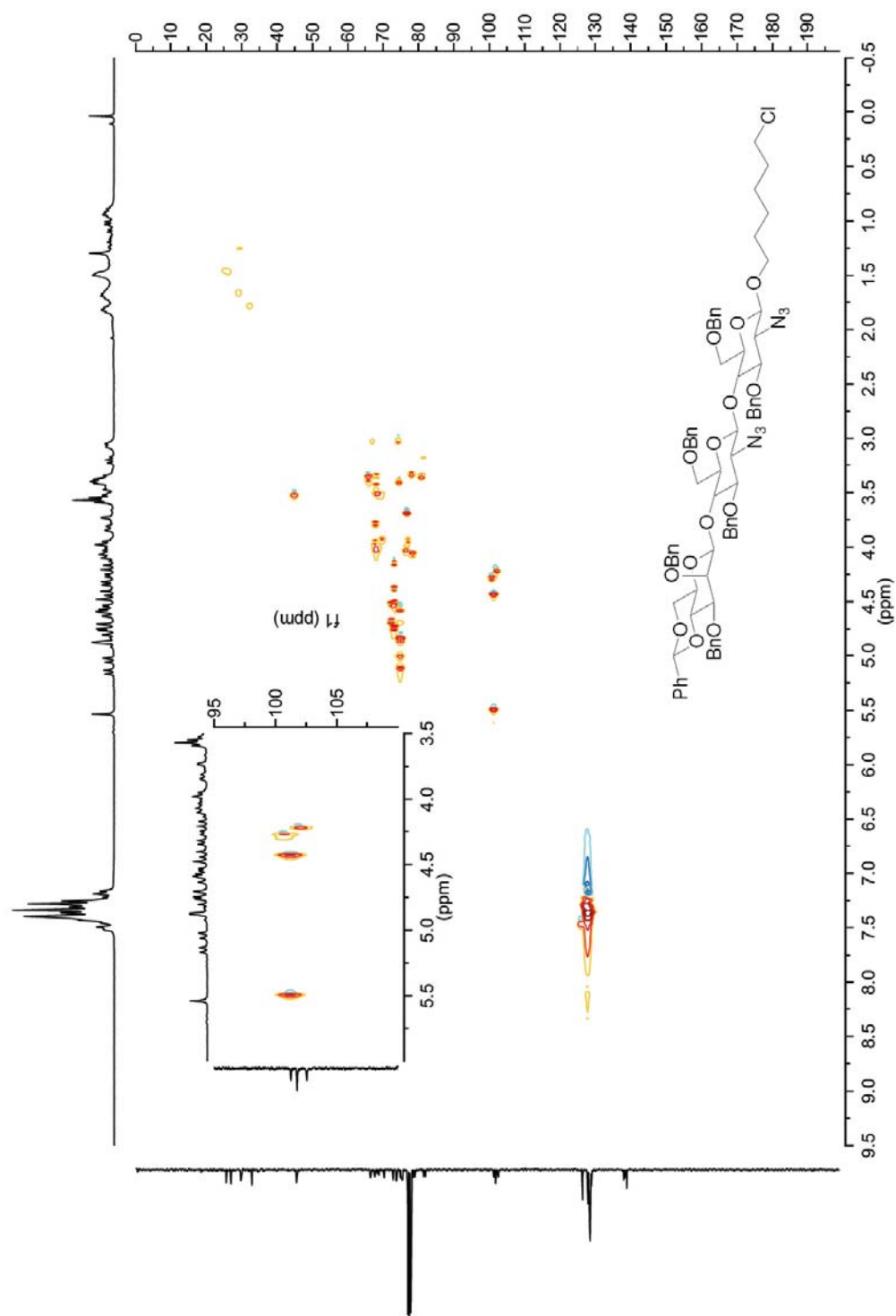

Non-decoupling ^{13}C NMR spectrum of (1-chlorohexyl) 2-azido-3,6-di-*O*-benzyl-2-deoxy-4-*O*-[2-azido-3,6-di-*O*-benzyl-4-*O*-(2,3-di-*O*-benzyl-4,6-*O*-benzylidene- β -D-mannopyranosyl)- β -D-glucospyranosyl] - β -D-glucospyranoside **14**

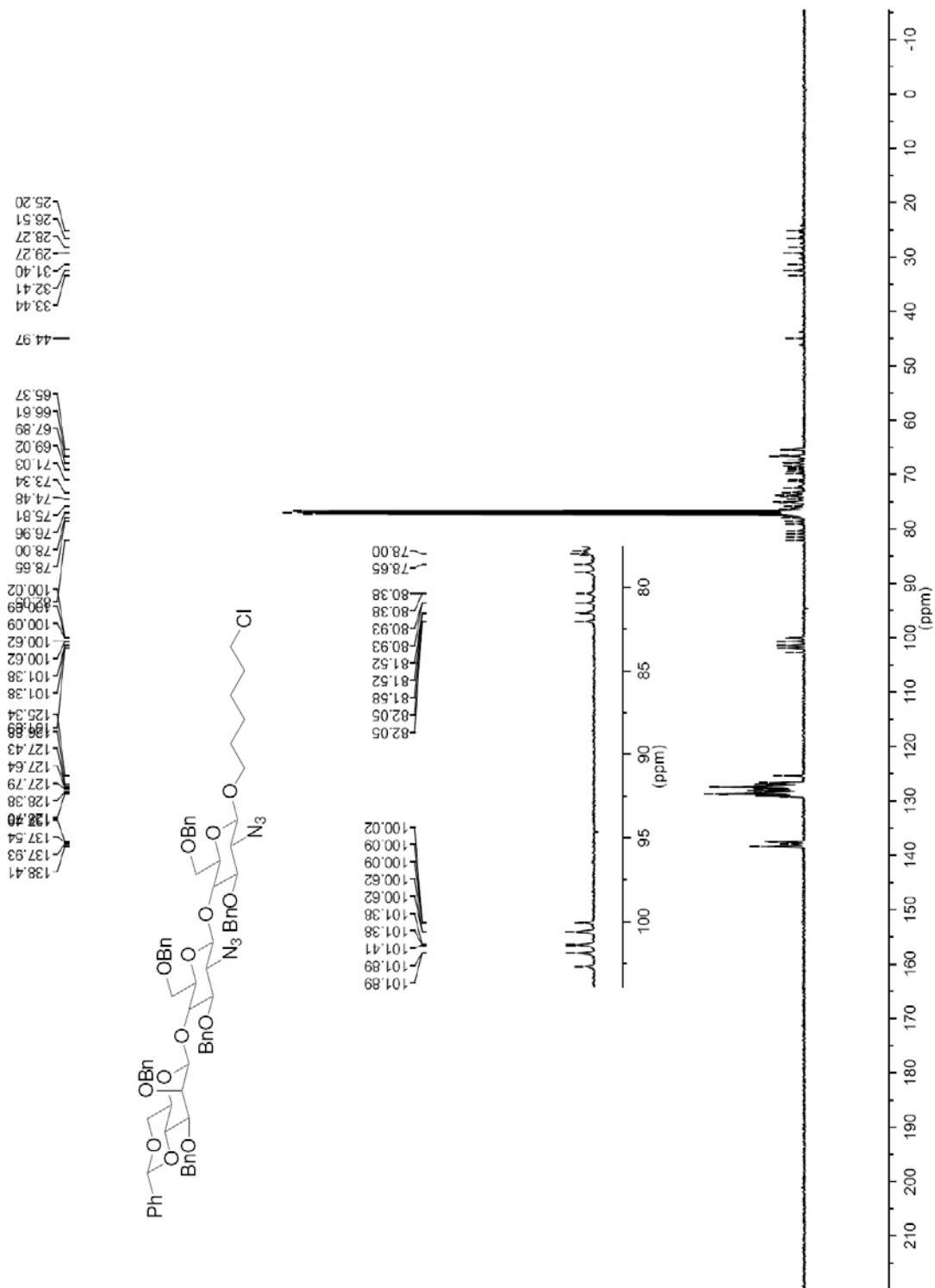

^1H NMR spectrum of (2,6-dimethylphenyl)-2,3-*O*-(isopropylidene)- α -L-rhamnopyranoside **15**

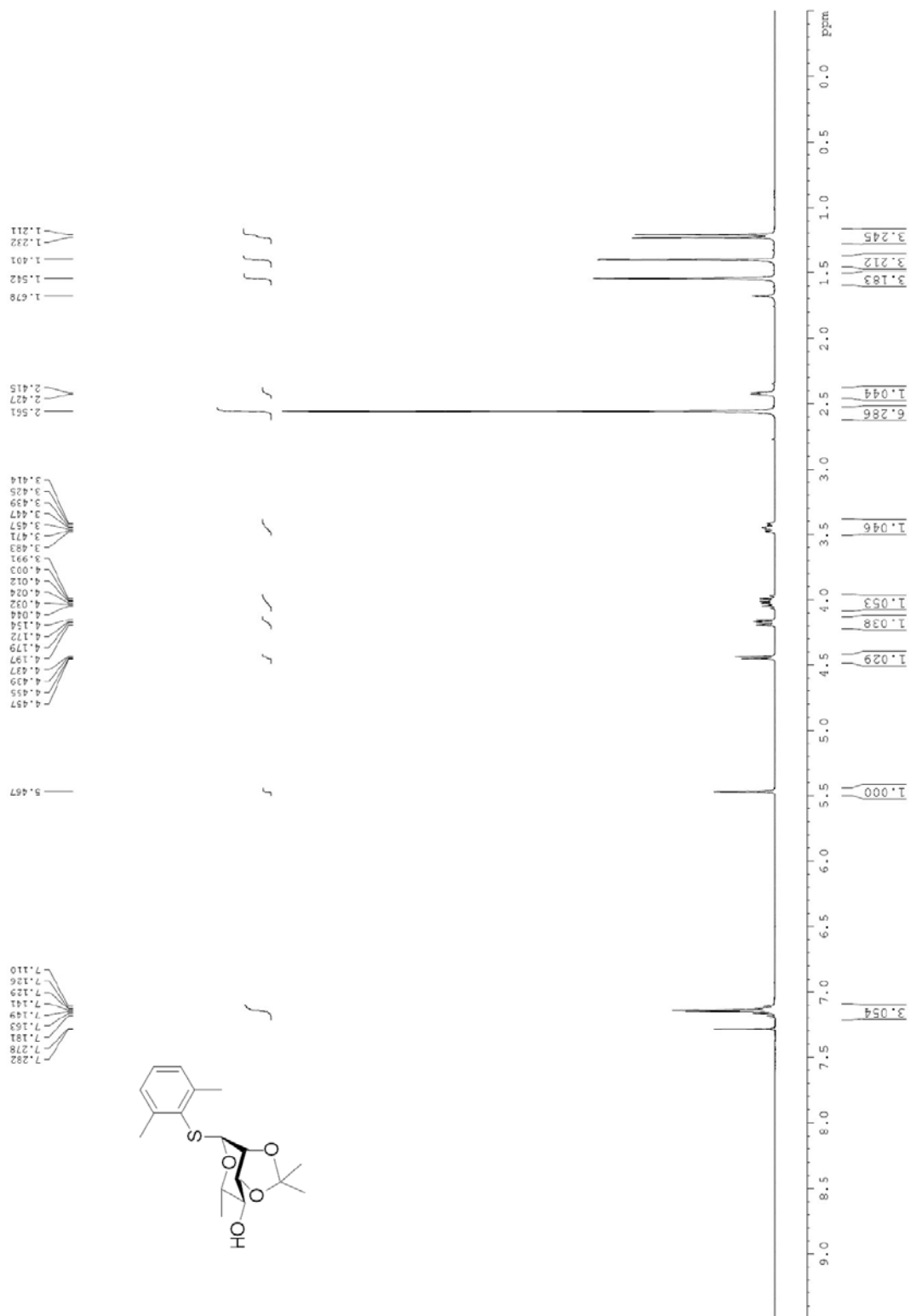

^{13}C NMR spectrum of (2,6-dimethylphenyl)-2,3-*O*-(isopropylidene)- α -L-rhamnopyranoside **15**

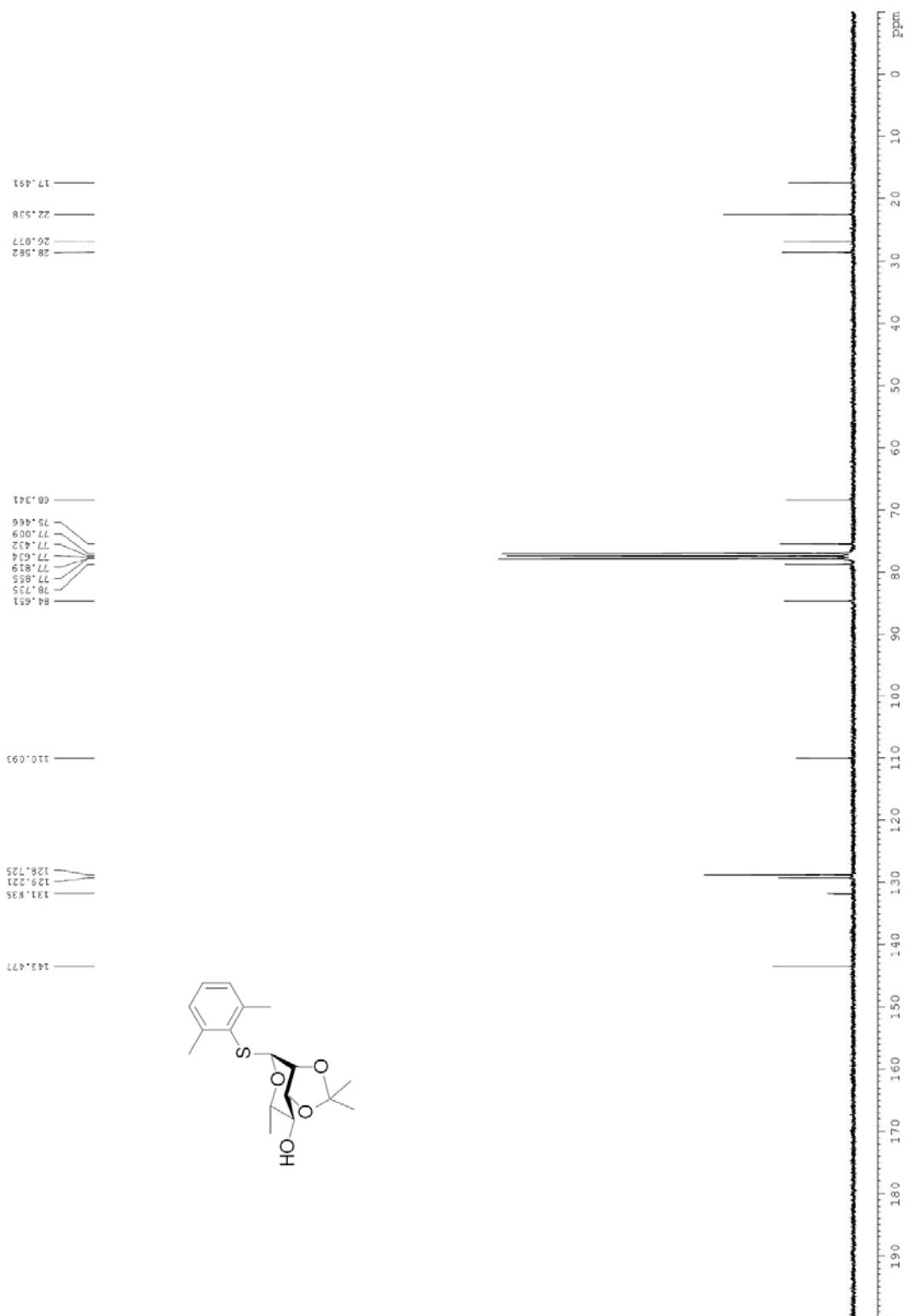

HMQC NMR spectrum of (2,6-di-methylphenyl)-2,3-*O*-(isopropylidene)- α -L-rhamnopyranoside **15**

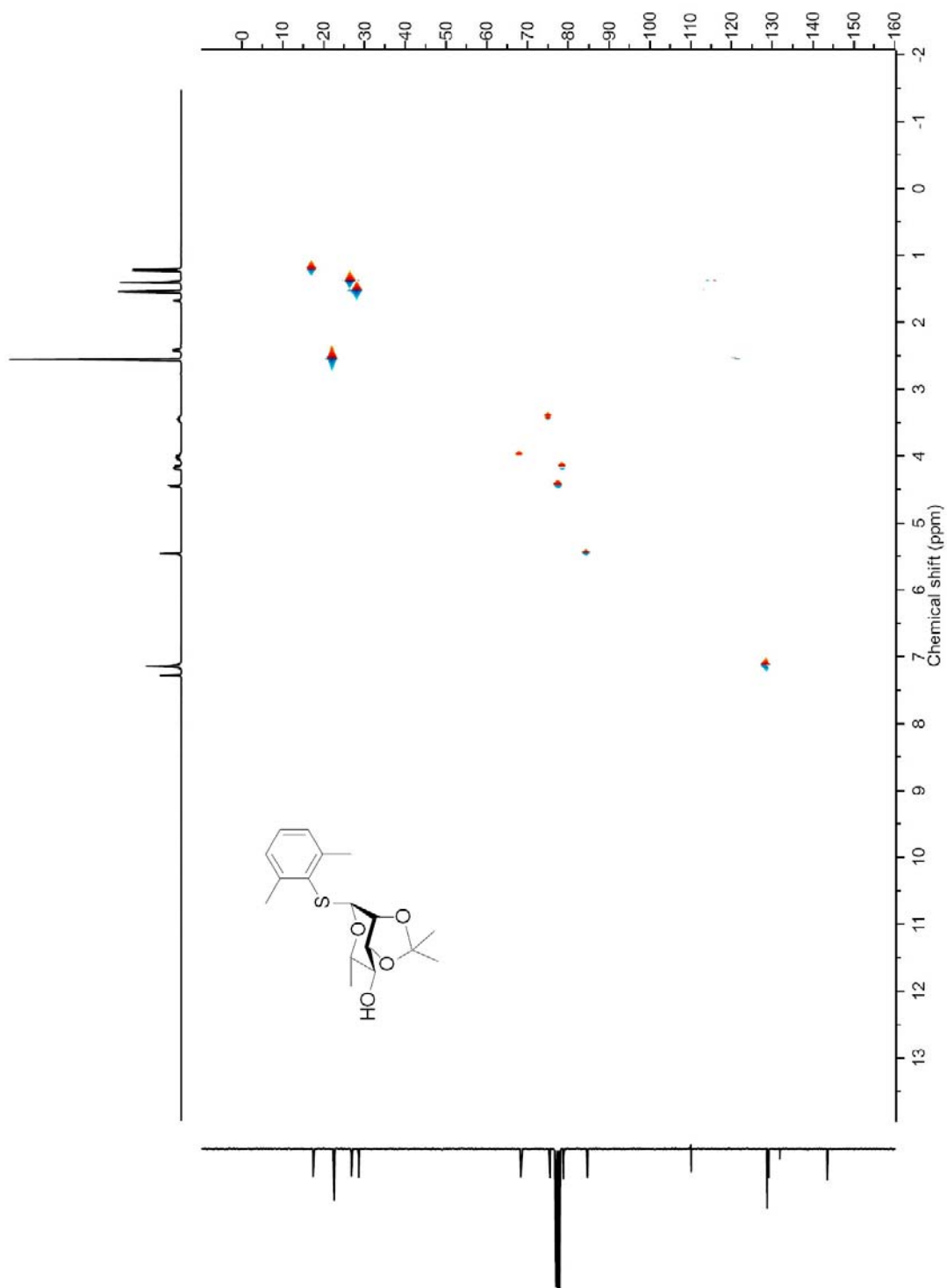

Gated decoupling ^{13}C NMR spectrum of (2,6-di-methylphenyl)-2,3-*O*-(isopropylidene)- α -L-rhamnopyranoside **15**

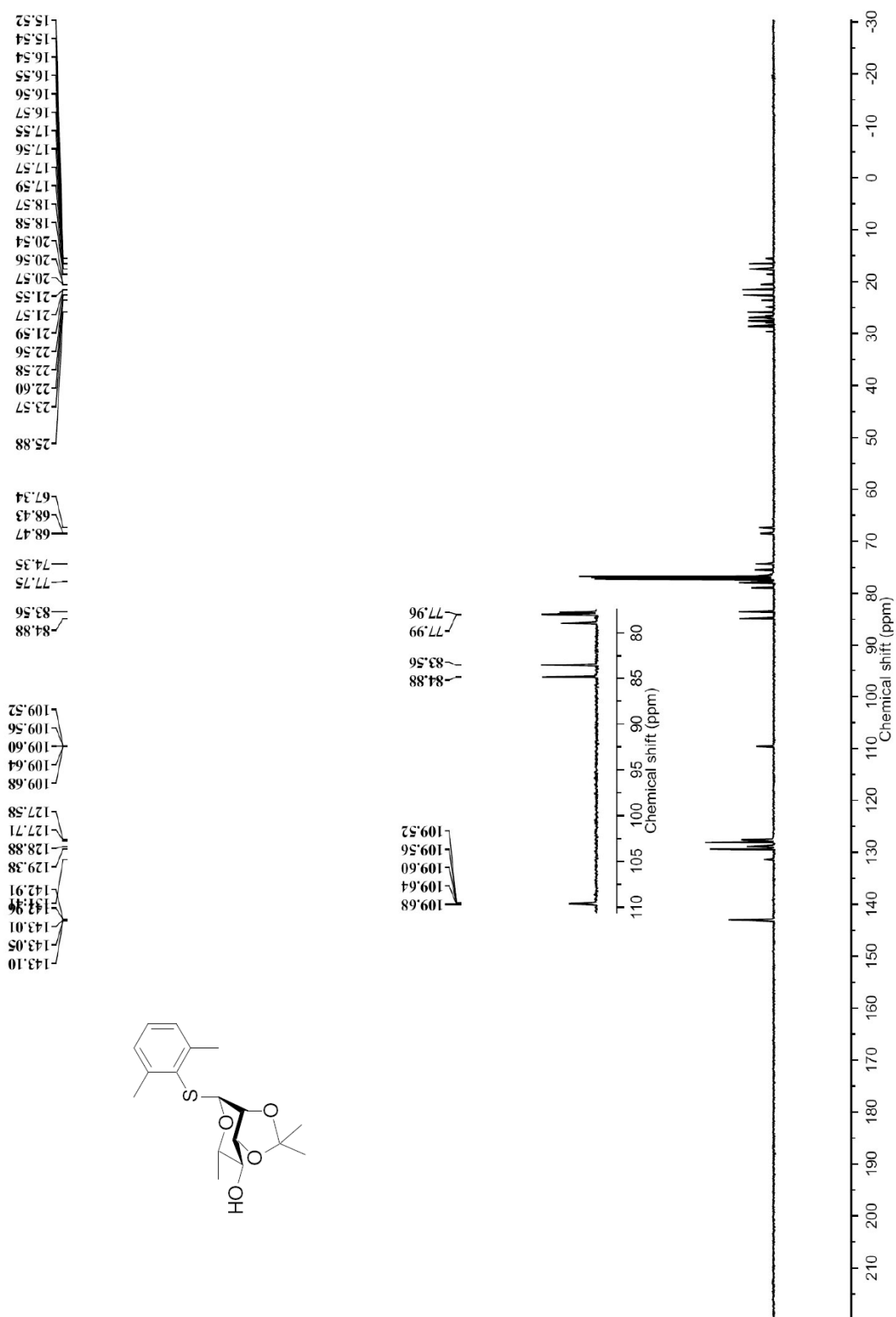

¹H NMR spectrum of 2-*O*-benzyl-4,6-*O*-benzylidene-3-*O*-*p*-methoxybenzyl- α -D-mannopyranosyl trichloroacetimidate **16**

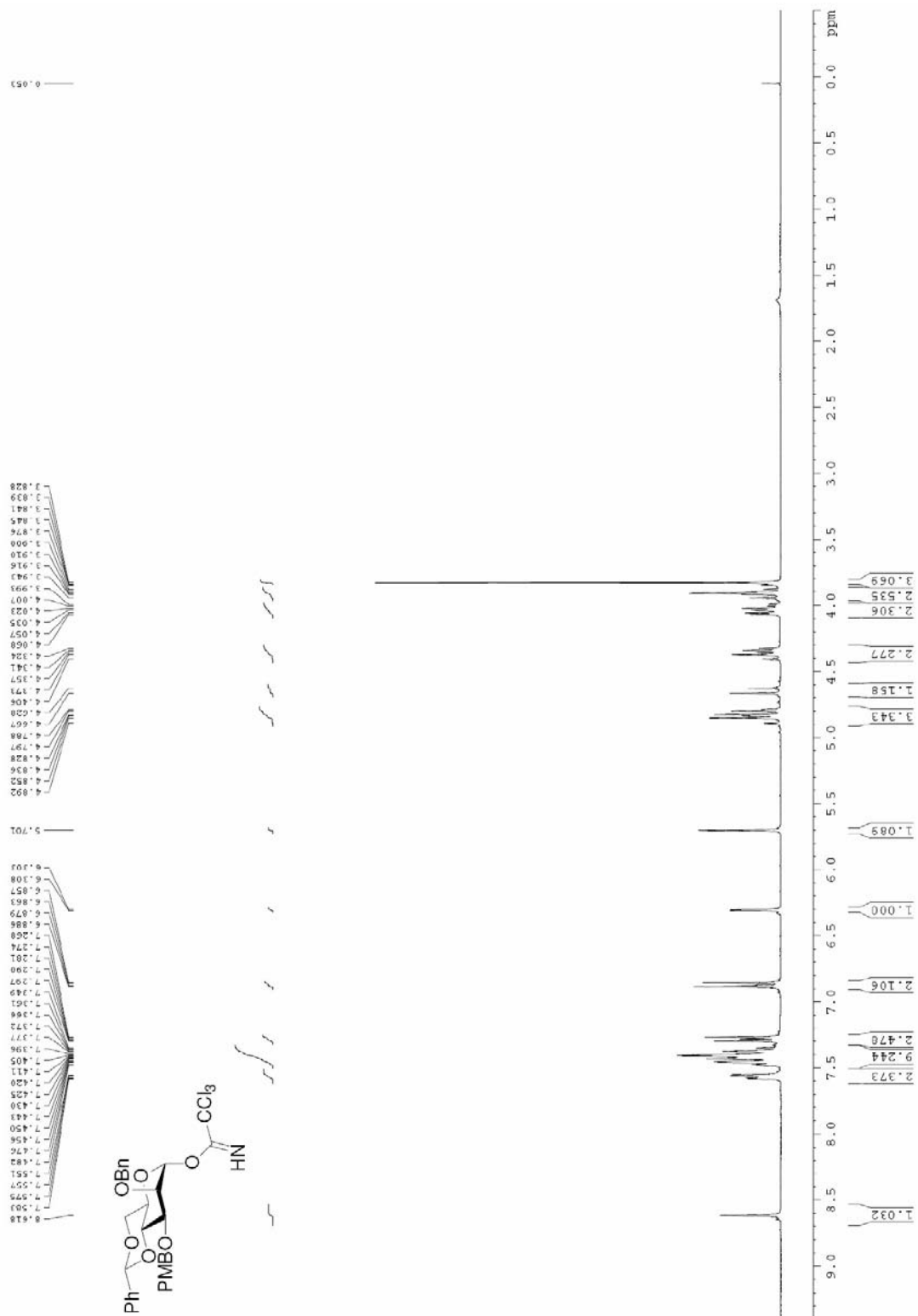

^{13}C NMR spectrum of 2-*O*-benzyl-4,6-*O*-benzylidene-3-*O*-*p*-methoxybenzyl- α -D-mannopyranosyl trichloroacetimidate **16**

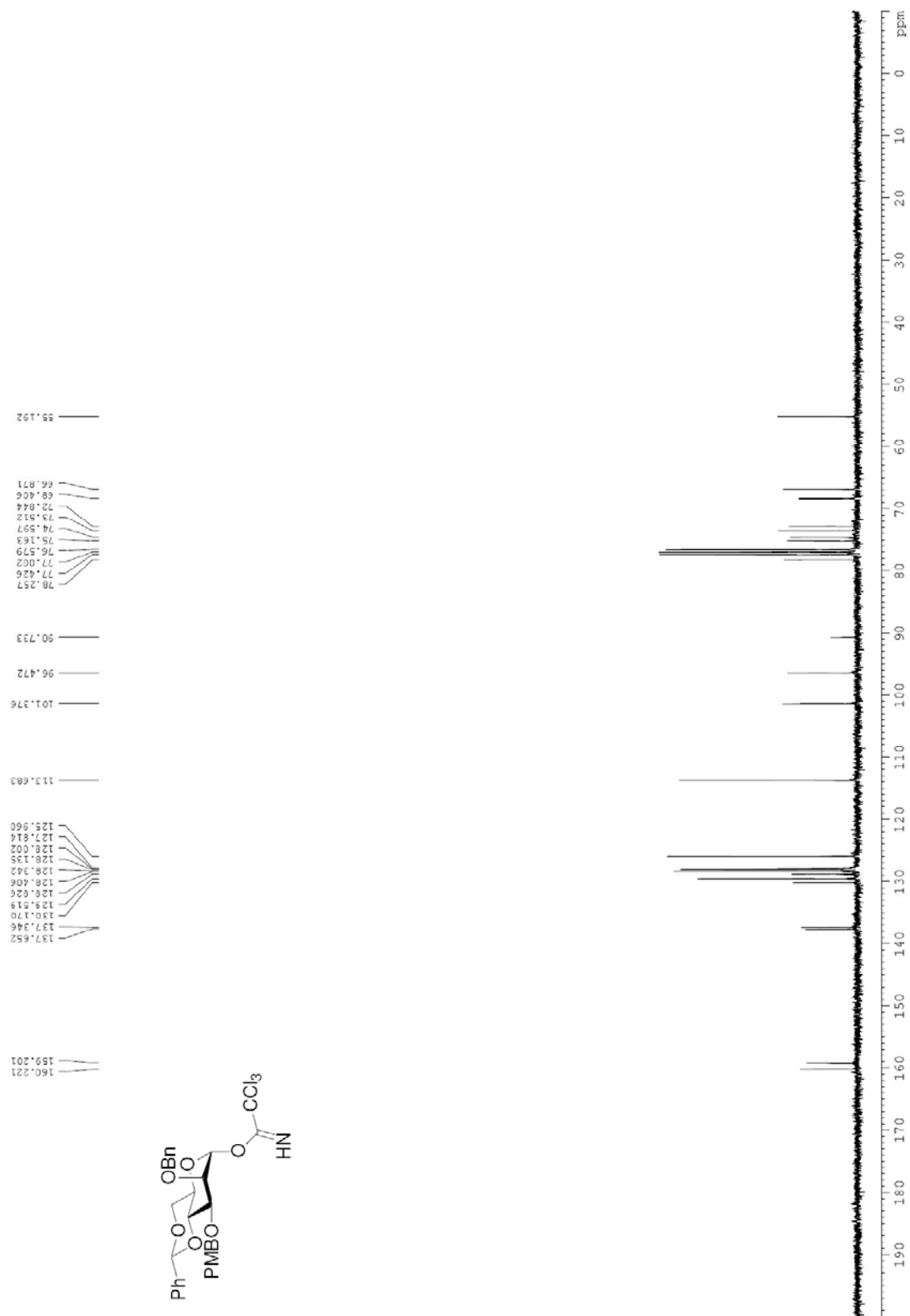

HMQC NMR spectrum of 2-*O*-benzyl-4,6-*O*-benzylidene-3-*O*-*p*-methoxybenzyl- α -D-mannopyranosyl trichloroacetimidate **16**

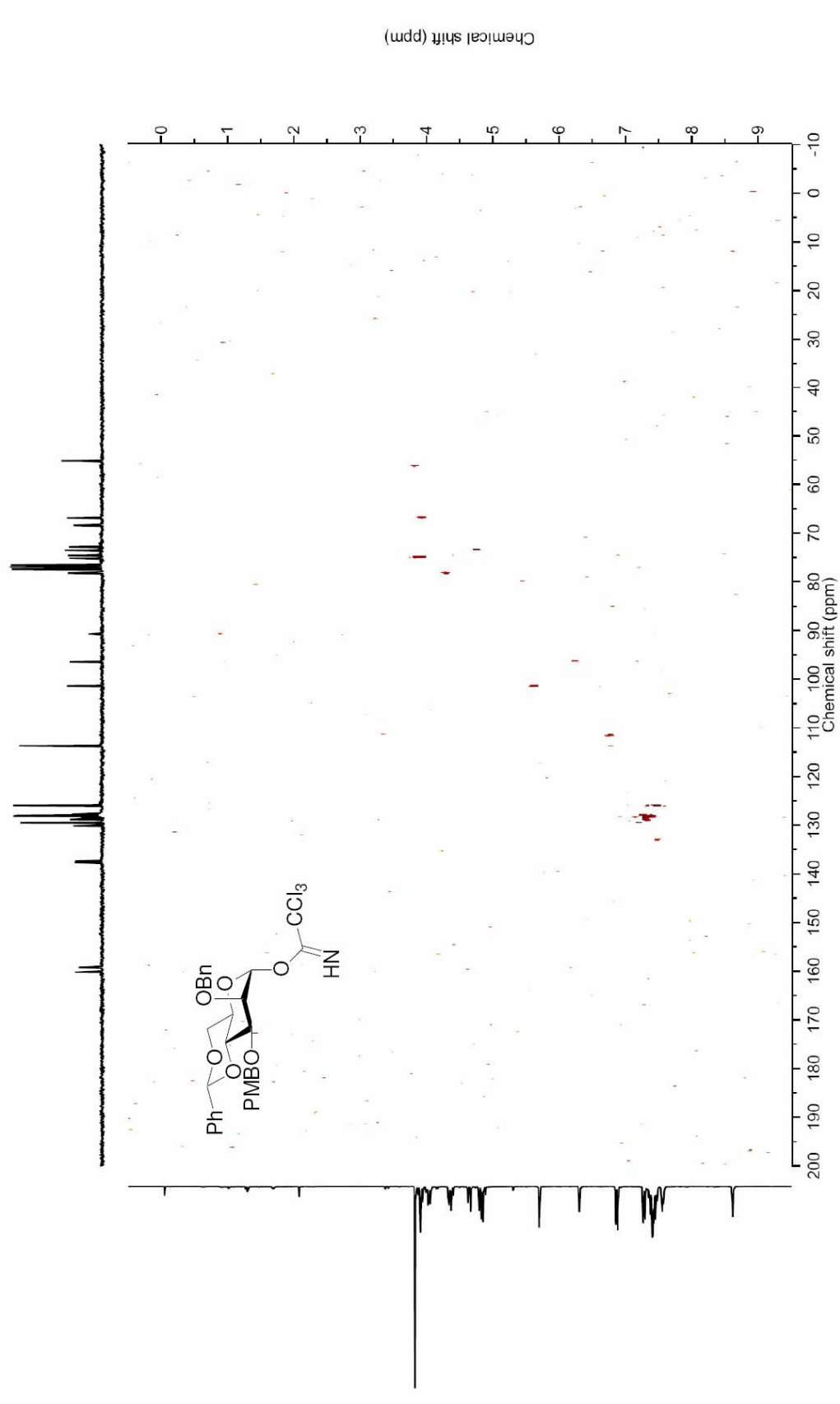

^1H NMR spectrum of *N*-(2-*O*-benzyl-4,6-*O*-benzylidene-3-*O*-*p*-methoxybenzyl-1- β -D-mannopyranosyl)-trichloroacetamide **17**

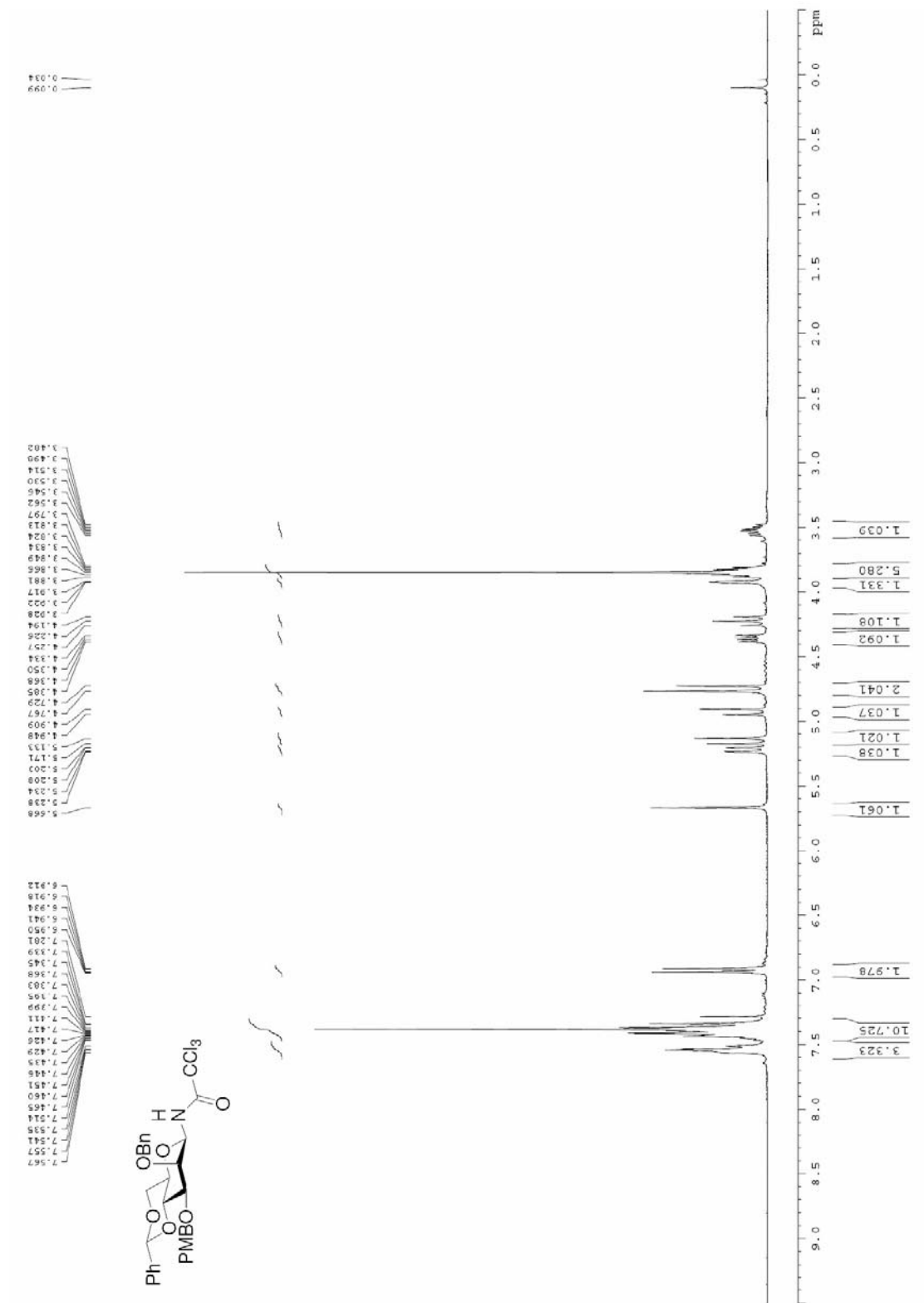

^{13}C NMR spectrum of *N*-(2-*O*-benzyl-4,6-*O*-benzylidene-3-*O*-*p*-methoxybenzyl-1- β -D-mannopyranosyl)-trichloroacetamide **17**

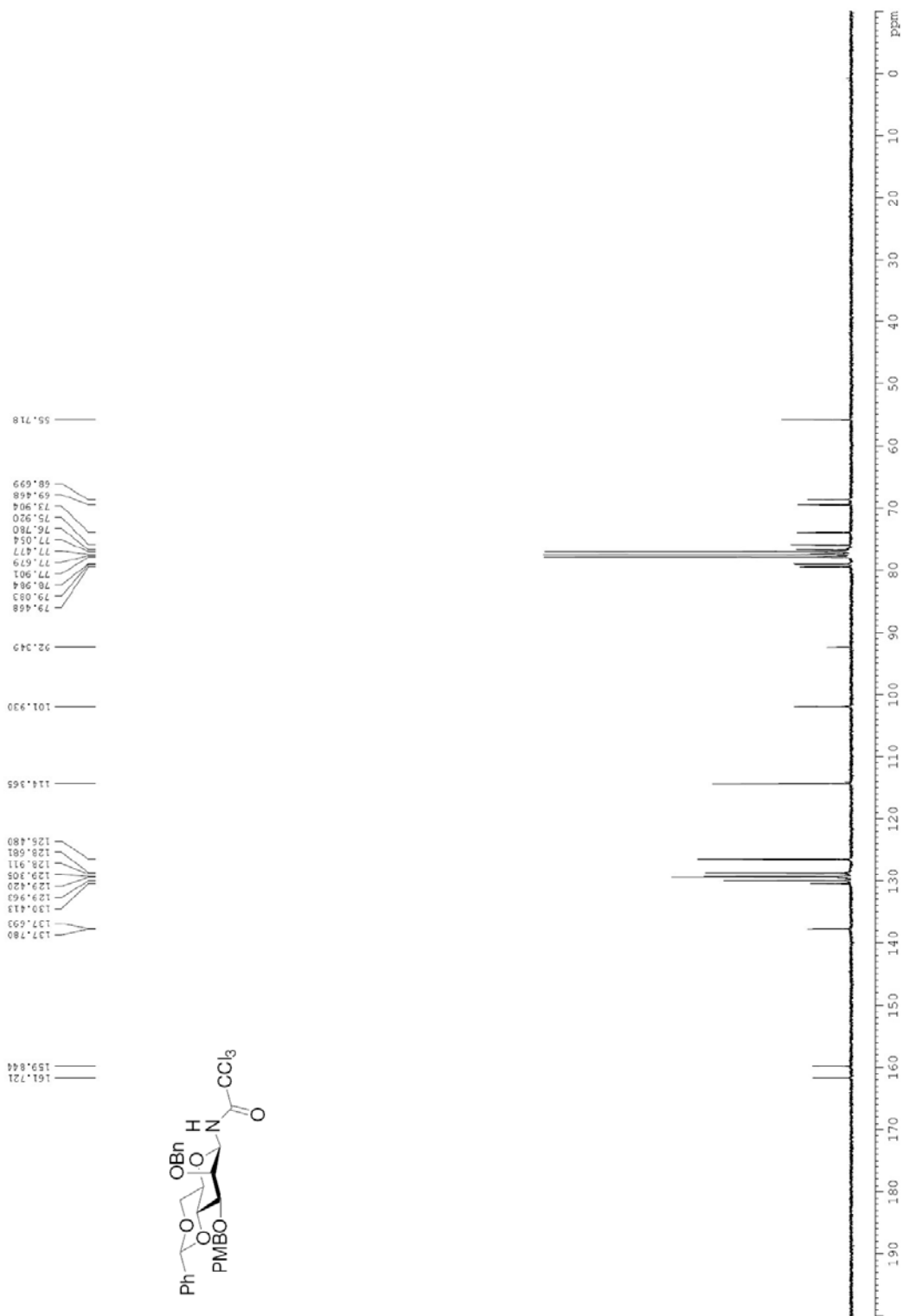

COSY NMR spectrum of *N*-(2-*O*-benzyl-4,6-*O*-benzylidene-3-*O*-*p*-methoxybenzyl-1- β -D-mannopyranosyl)-trichloroacetamide **17**

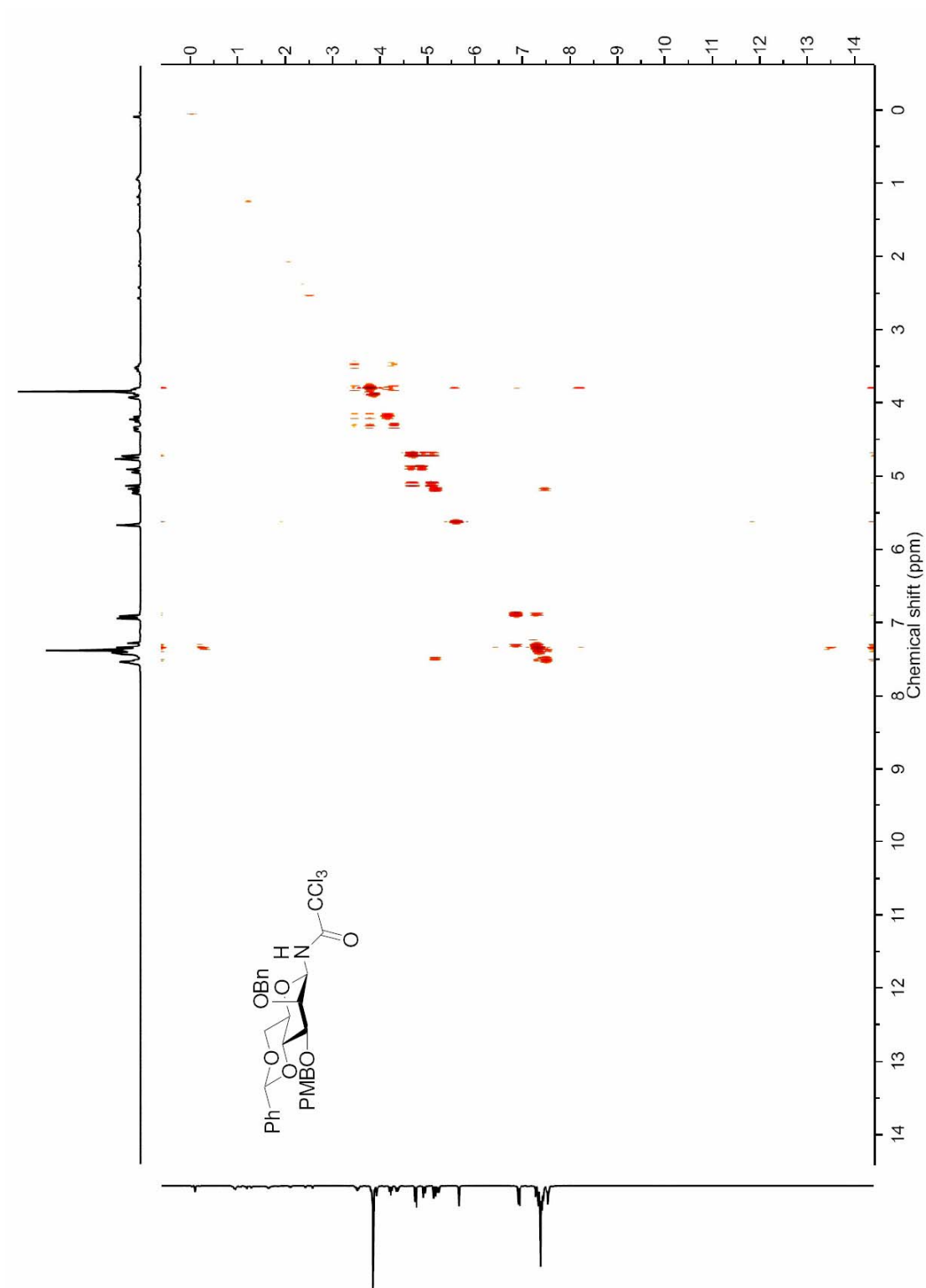

HMQC NMR spectrum of *N*-(2-*O*-benzyl-4,6-*O*-benzylidene-3-*O*-*p*-methoxybenzyl-1- β -D-mannopyranosyl)-trichloroacetamide **17**

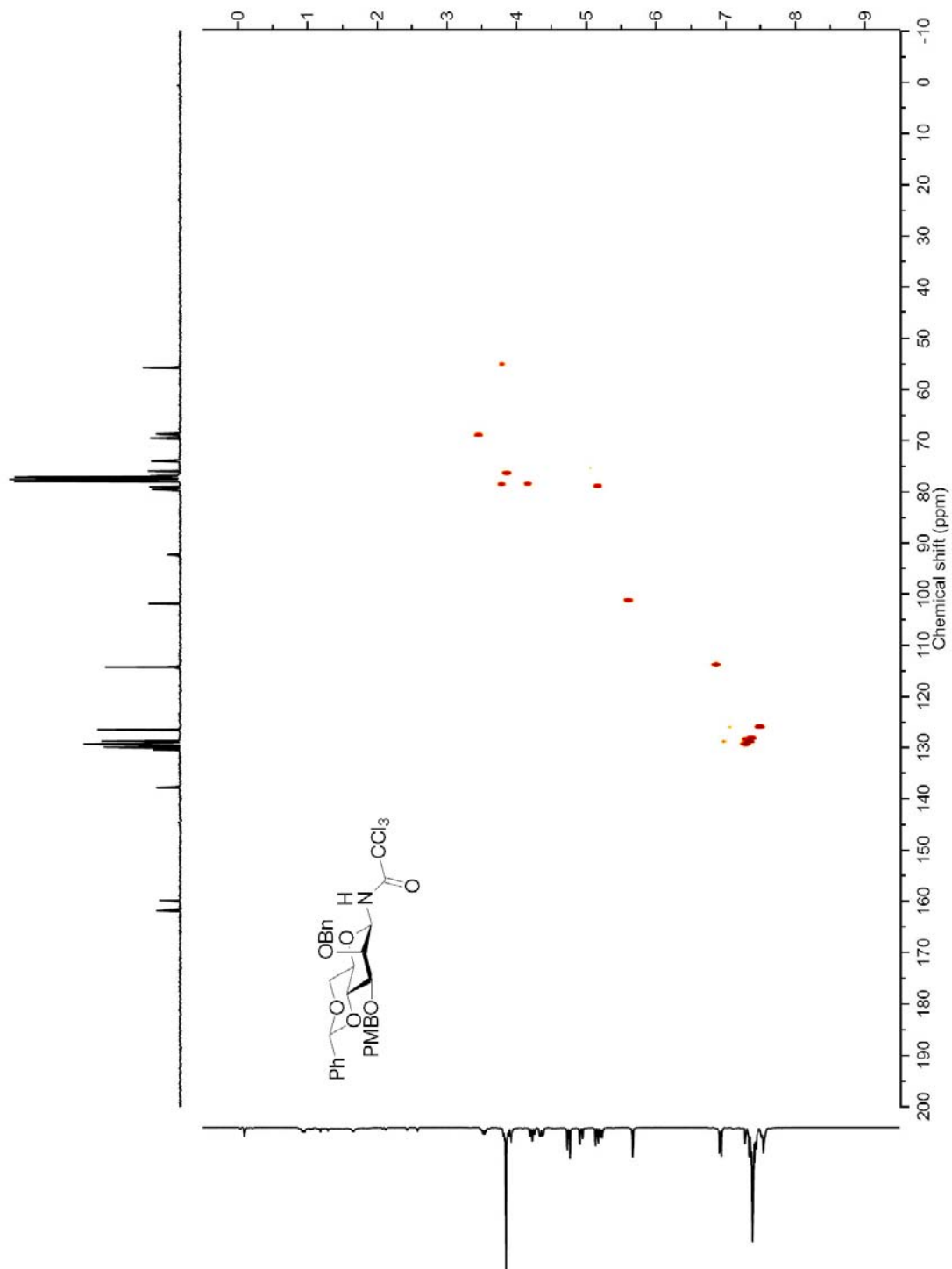

Gated decoupling ^{13}C NMR spectrum of *N*-(2-*O*-benzyl-4,6-*O*-benzylidene-3-*O*-*p*-methoxybenzyl-1- β -D-mannopyranosyl)-trichloroacetamide **17**

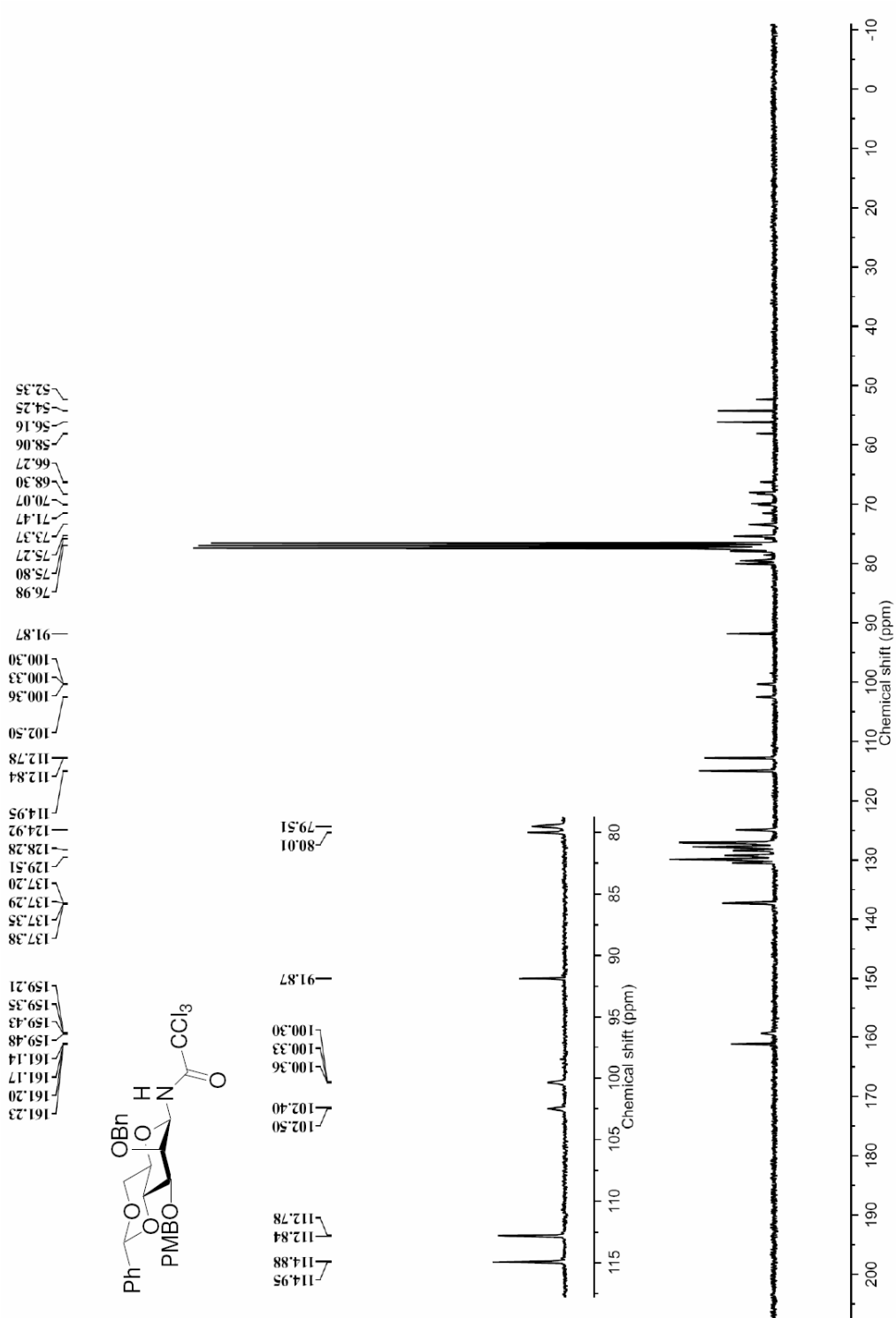

¹H NMR spectrum of methyl 2,3,6-tri-*O*-benzyl-4-*O*-(2,3-di-*O*-benzyl-β-D-mannopyranosyl)-α-D-glucopyranoside **20**

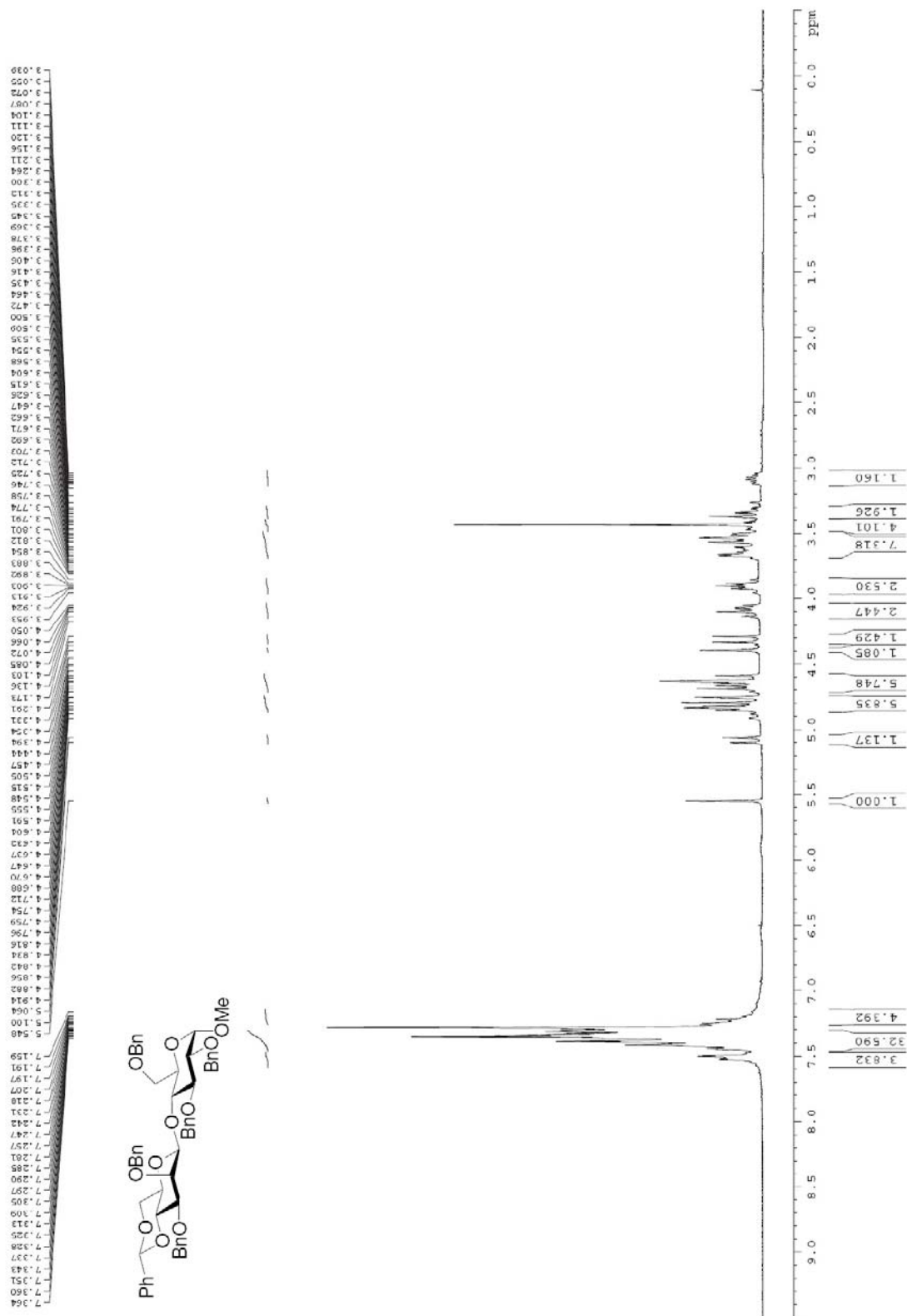

^{13}C NMR spectrum of methyl 2,3,6-tri-*O*-benzyl-4-*O*-(2,3-di-*O*-benzyl- β -D-mannopyranosyl)- α -D-glucopyranoside **20**

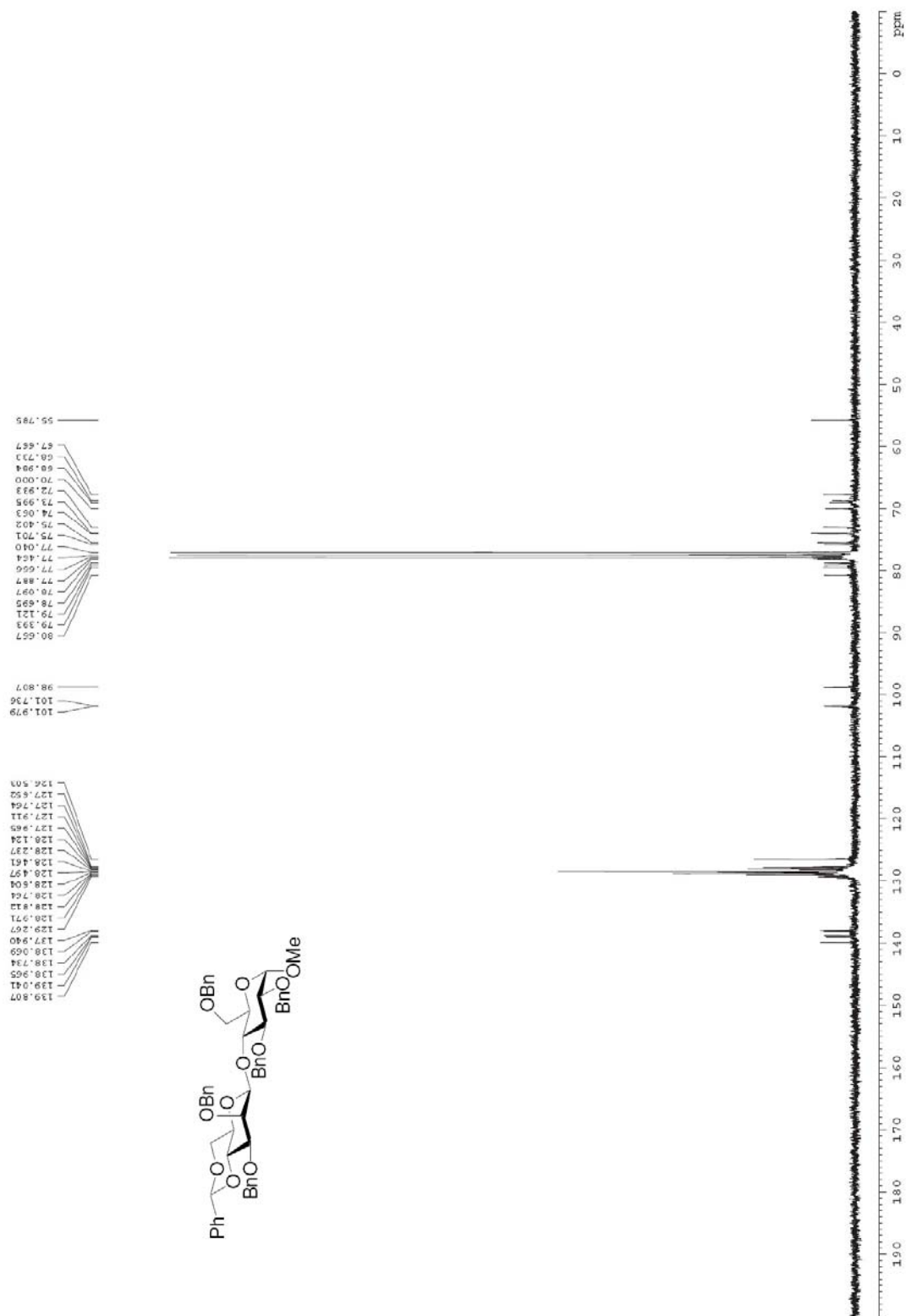

^1H NMR spectrum of 1,2,3,4-di-*O*-isopropylidene-6-*O*-(2,3-di-*O*-benzyl -4,6-benzylidene- β -D-mannopyranosyl)- α -D-galactopyranoside **21**

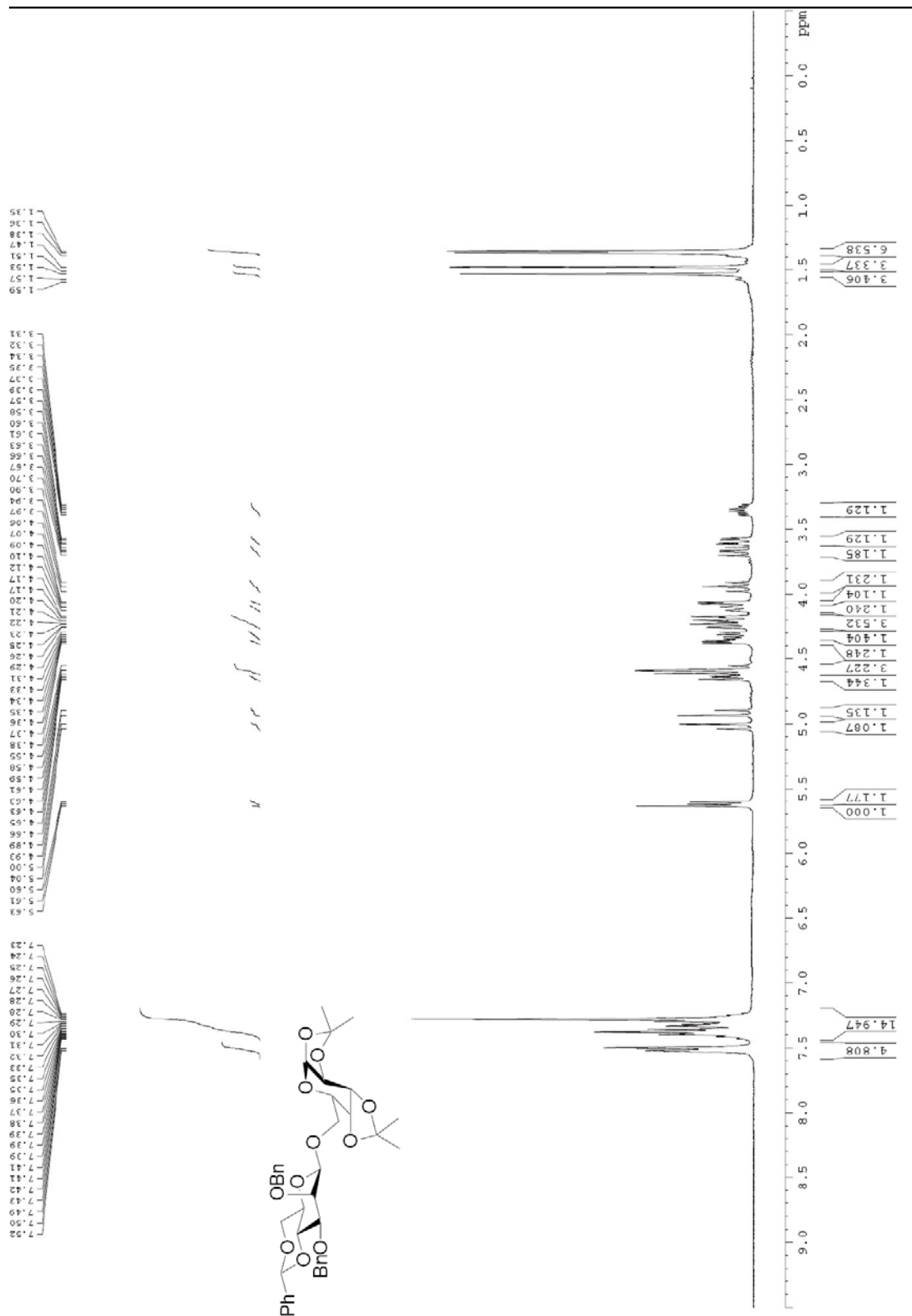

^{13}C NMR spectrum of 1,2,3,4-di-*O*-isopropylidene-6-*O*-(2,3-di-*O*-benzyl-4,6-benzylidene- β -D-mannopyranosyl)- α -D-galactopyranoside **21**

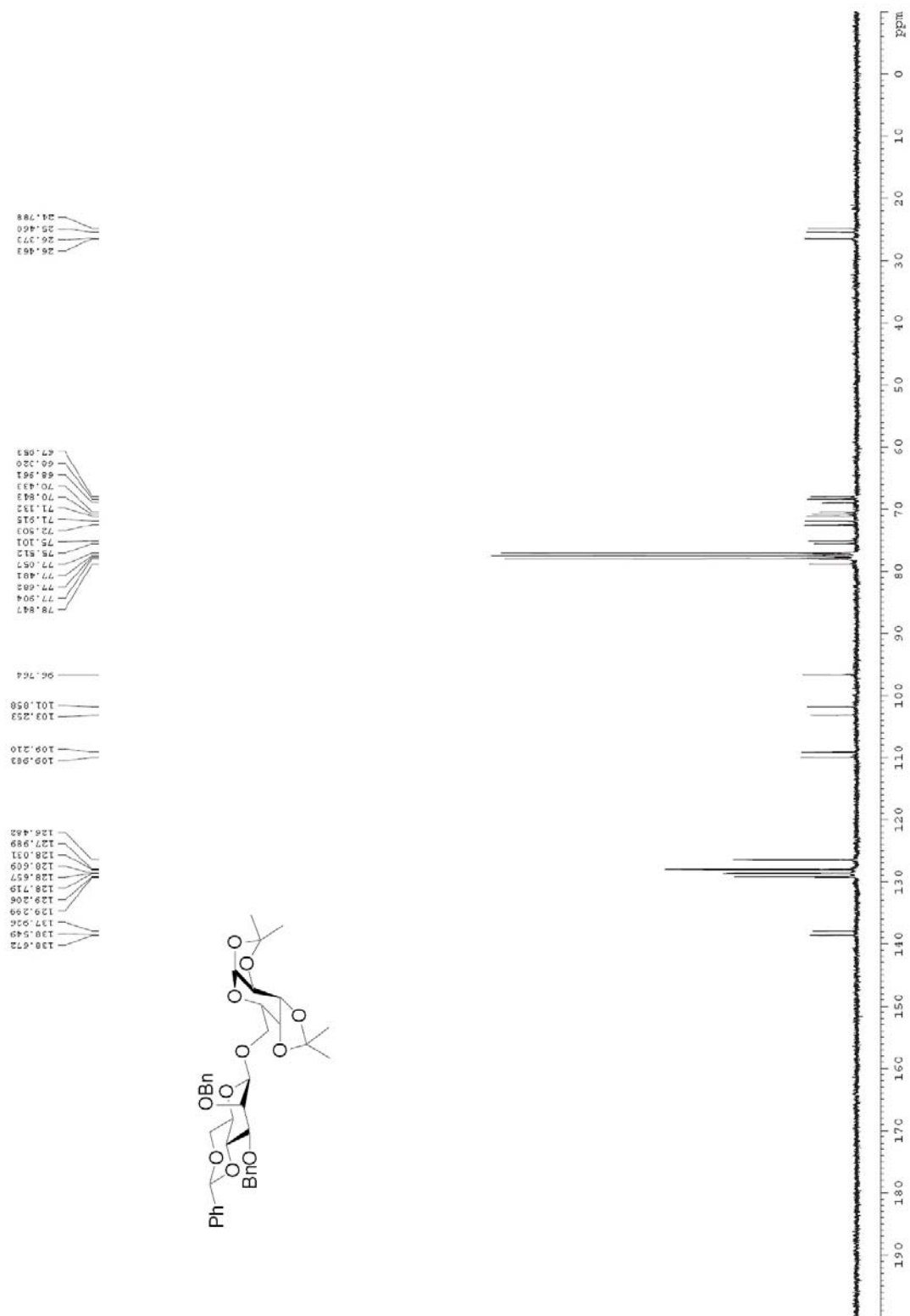

^1H NMR spectrum of 6-chlorohexyl 3,6-di-*O*-benzyl-2-azido-2-deoxy 4-*O*-[3-*O*-acetyl-6-*O*-benzyl-2-(trichloroethyloxycarbonyl)-4-*O*-(2-*O*-benzyl-3-*O*-*p*-methoxybenzyl- β -D-mannopyranosyl)- β -D-glucopyranosyl]- β -D-glucopyranoside **22**

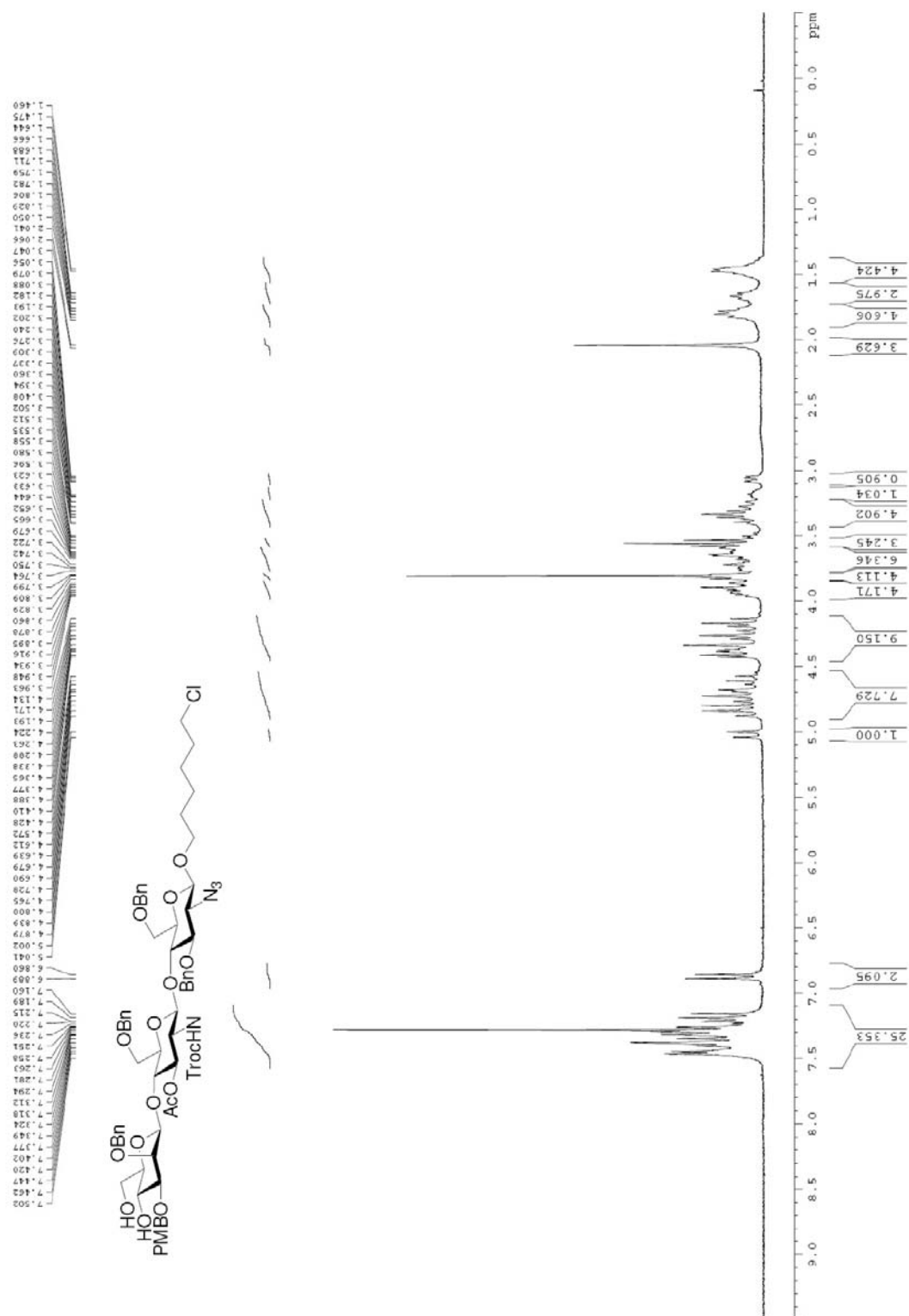

^{13}C NMR spectrum of 6-chlorohexyl 3,6-di-*O*-benzyl-2-azido-2-deoxy 4-*O*-[3-*O*-acetyl-6-*O*-benzyl-2-(trichloroethoxy carbamyl)-4-*O*-(2-*O*-benzyl-3-*O*-*p*-methoxybenzyl- β -D-mannopyranosyl)- β -D-glucopyranosyl]- β -D-glucopyranoside **22**

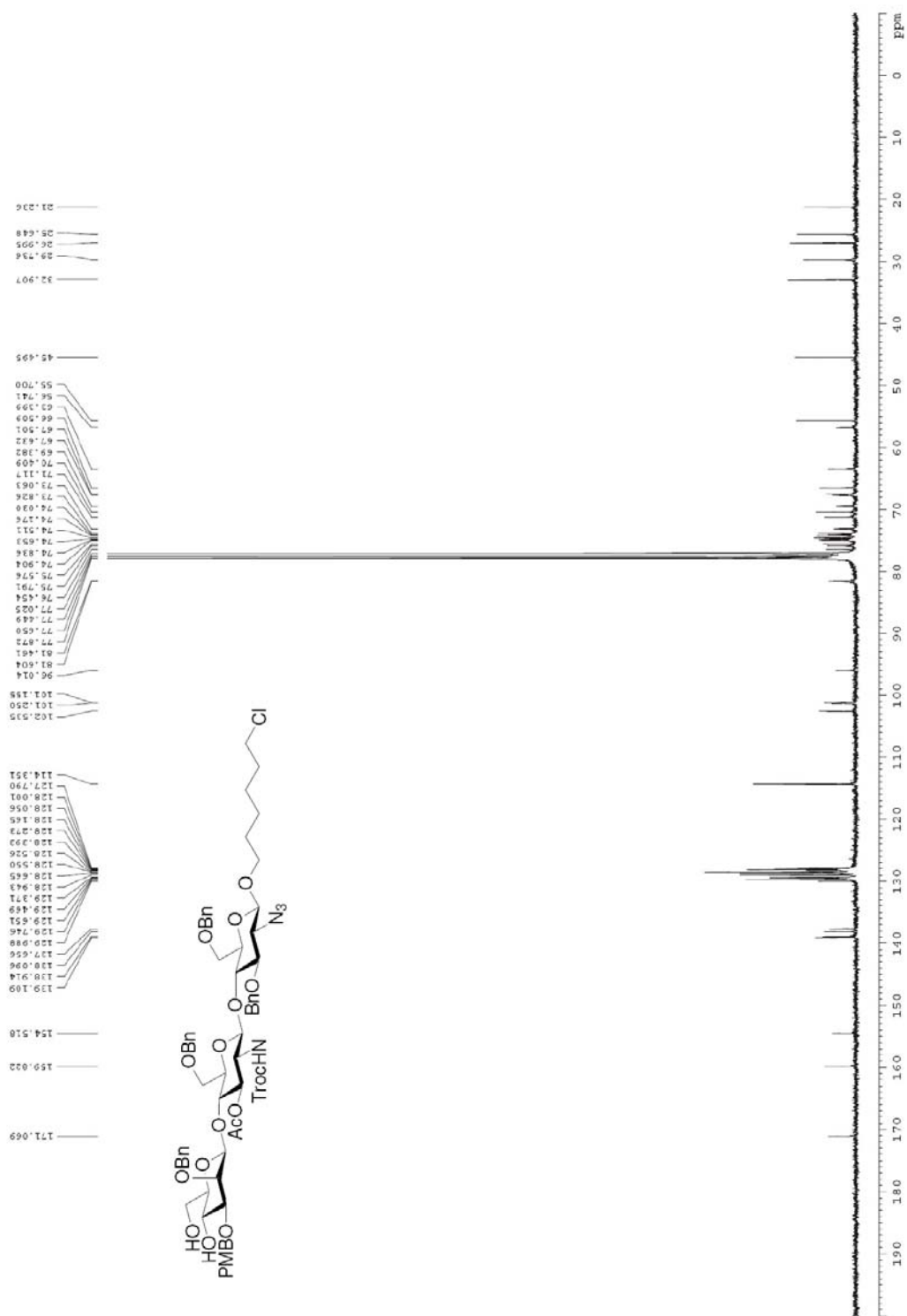

HMQC NMR spectrum of 6-chlorohexyl 3,6-di-*O*-benzyl-2-azido-2-Deoxy-4-*O*-[3-*O*-acetyl-6-*O*-benzyl-2-(trichloroethoxy)carbonyl)-4-*O*-(2-*O*-benzyl-3-*O*-*p*-methoxybenzyl- β -D-mannopyranosyl)- β -D-glucopyranosyl]- β -D-glucopyranoside **22**

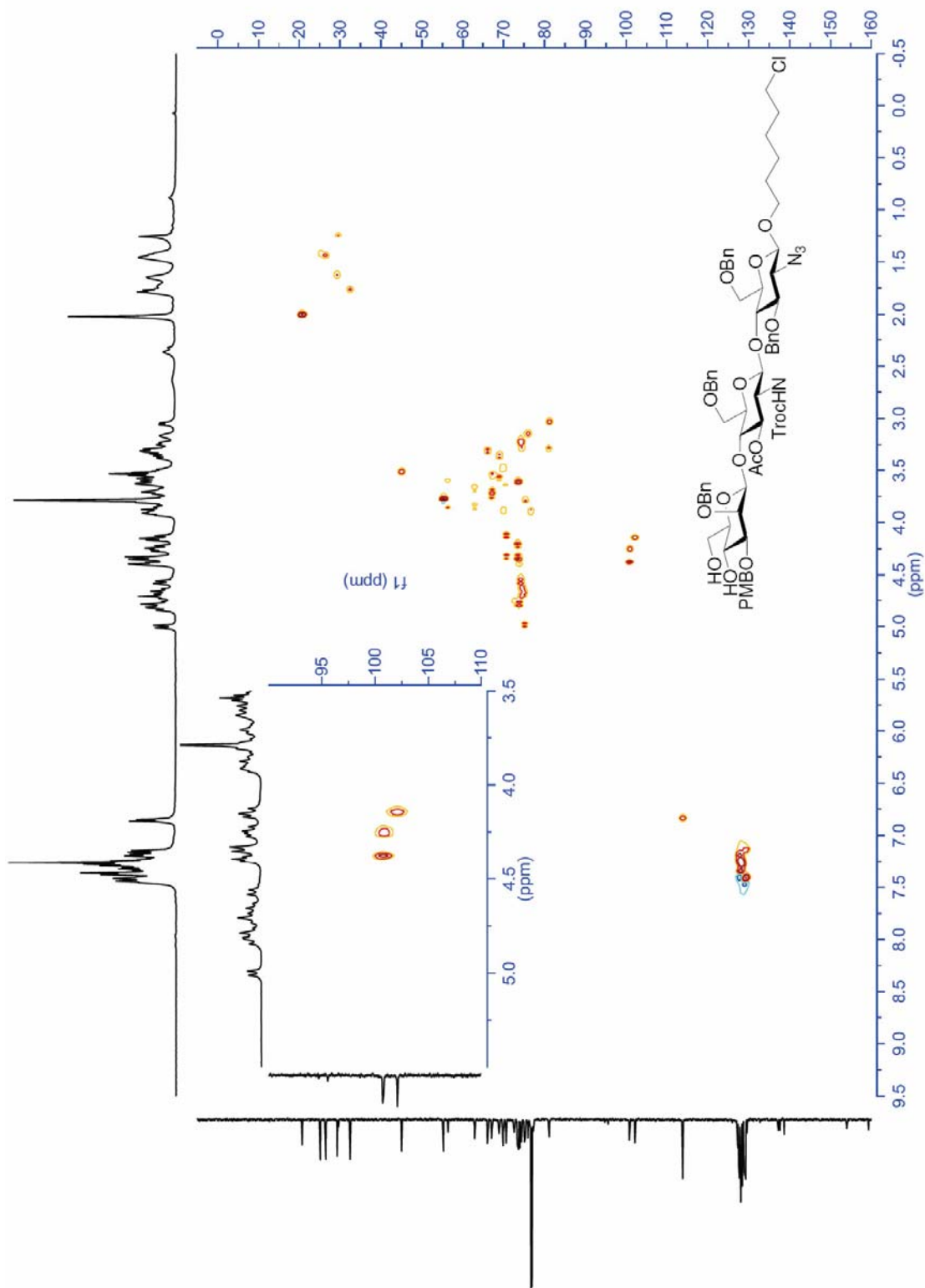

Gated decoupling ^{13}C NMR spectrum of 6-chlorohexyl 3,6-di-*O*-benzyl-2-azido-2-Deoxy-4-*O*-[3-*O*-acetyl-6-*O*-benzyl-2-(trichloroethyloxycarbonyl)-4-*O*-(2-*O*-benzyl-3-*O*-*p*-methoxybenzyl- β -D-mannopyranosyl)- β -D-glucopyranosyl]- β -D-glucopyranoside **22**

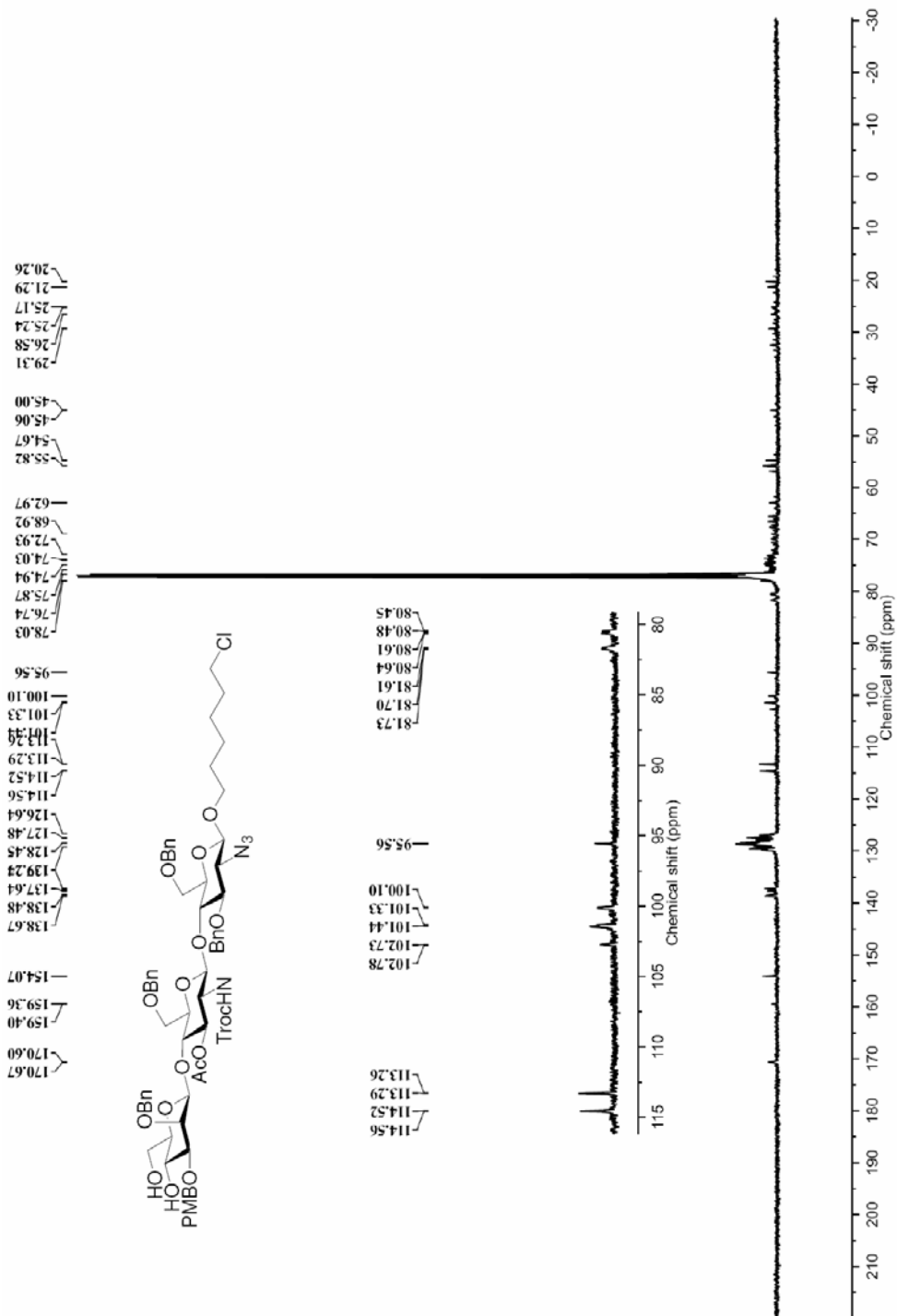

¹H NMR spectrum of (2,6-dimethylphenyl) 2,3-*O*-isopropylidene-4-*O*-(2,3-di-*O*-benzyl-4,6-*O*-benzylidene-β-D-mannopyranosyl)-1-thio-α-L-rhamnopyranoside **23**

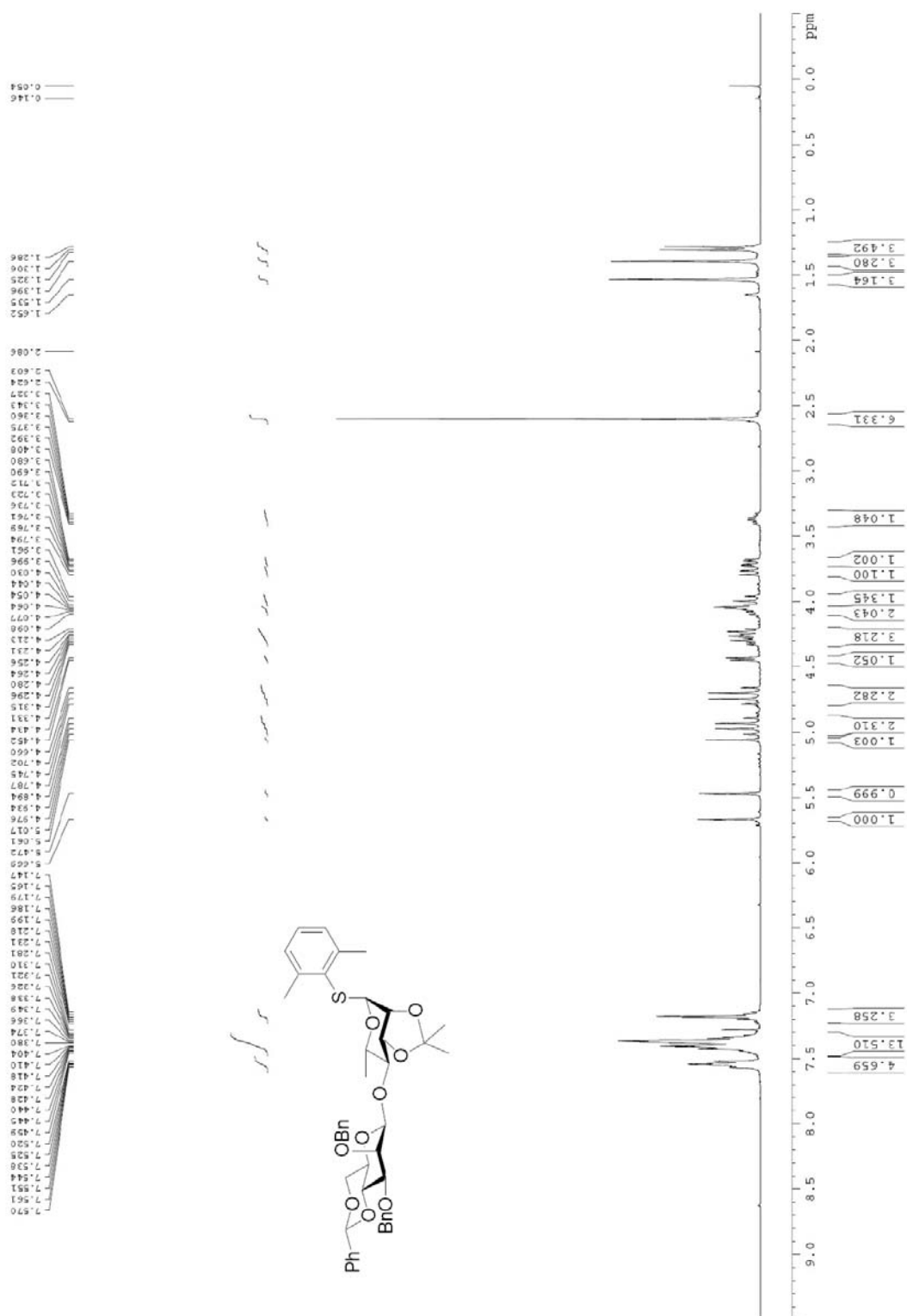

^{13}C NMR spectrum of (2,6-dimethylphenyl) 2,3-*O*-isopropylidene-4-*O*-(2,3-di-*O*-benzyl-4,6-*O*-benzylidene- β -D-mannopyranosyl)-1-thio- α -L-rhamnopyranoside **23**

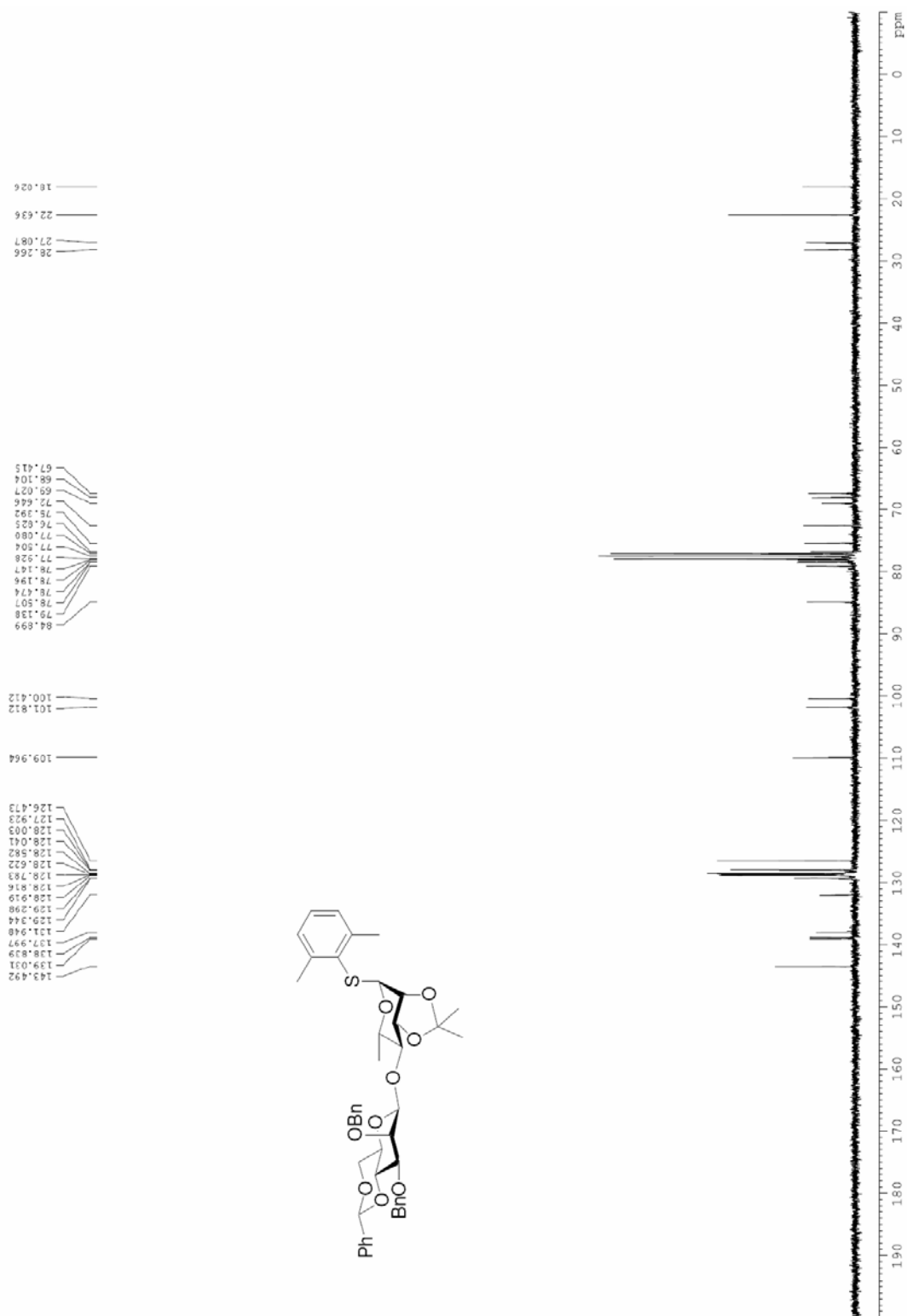

COSY NMR spectrum of (2,6-dimethylphenyl) 2,3-*O*-isopropylidene-4-*O*-(2,3-di-*O*-benzyl-4,6-*O*-benzylidene- β -D-mannopyranosyl)-1-thio- α -L-rhamnopyranoside **23**

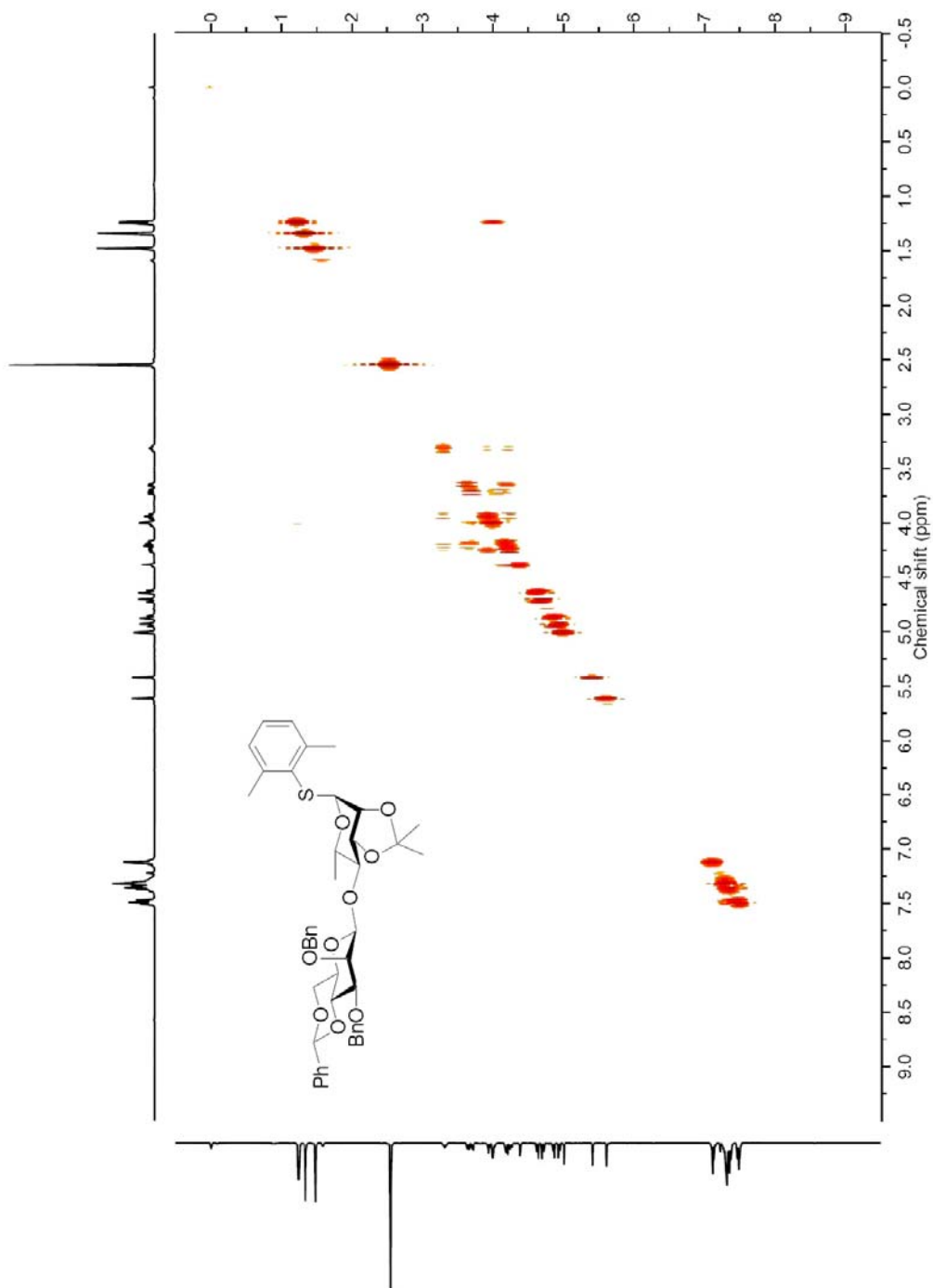

HMQC NMR spectrum of (2,6-dimethylphenyl) 2,3-*O*-isopropylidene-4-*O*-(2,3-di-*O*-benzyl-4,6-*O*-benzylidene- β -D-mannopyranosyl)-1-thio- α -L-rhamnopyranoside **23**

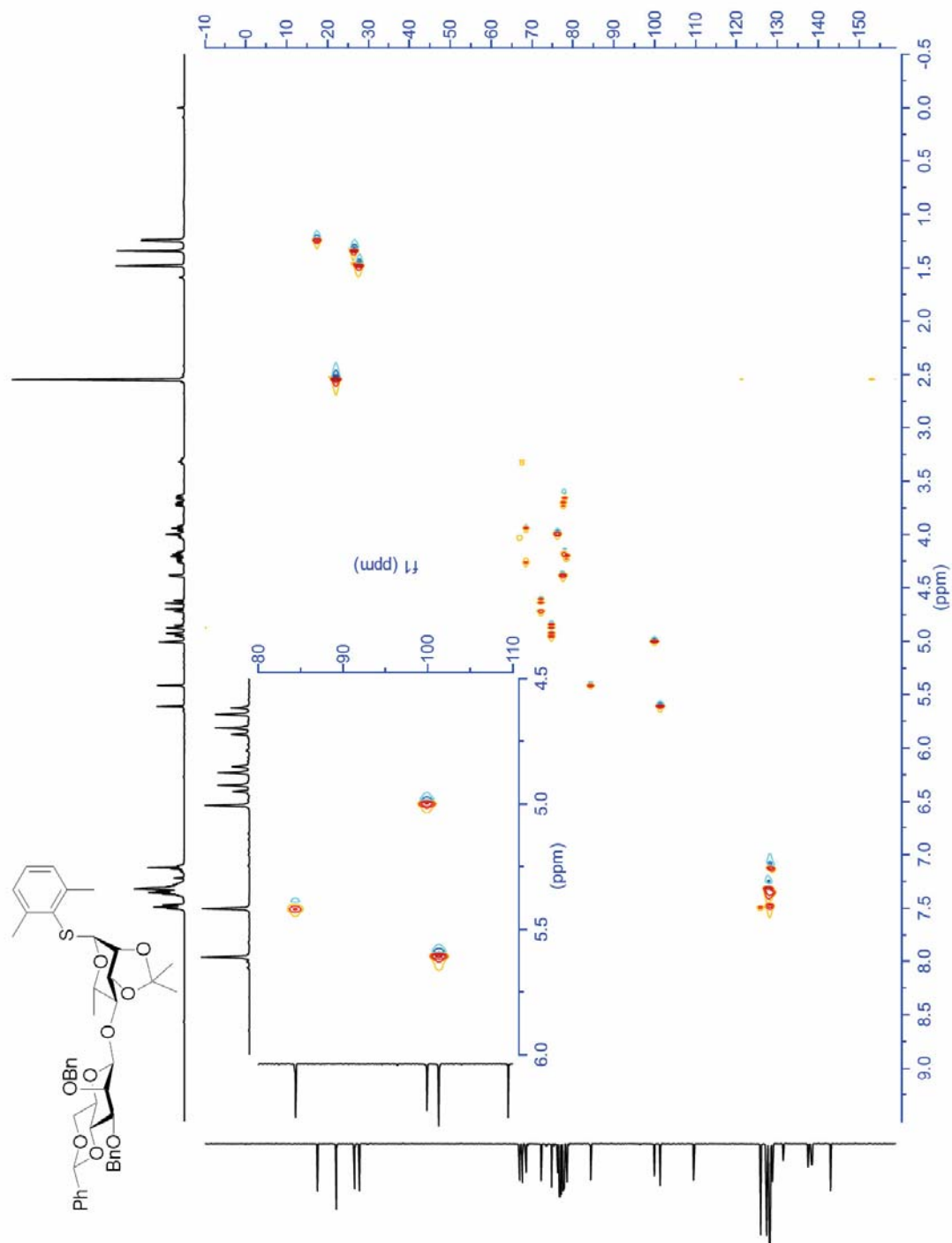

Gated decoupling C^{13} NMR spectrum of (2,6-dimethylphenyl) 2,3-*O*-isopropylidene-4-*O*-(2,3-di-*O*-benzyl-4,6-*O*-benzylidene- β -D-mannopyranosyl)-1-thio- α -L-rhamnopyranoside **23**

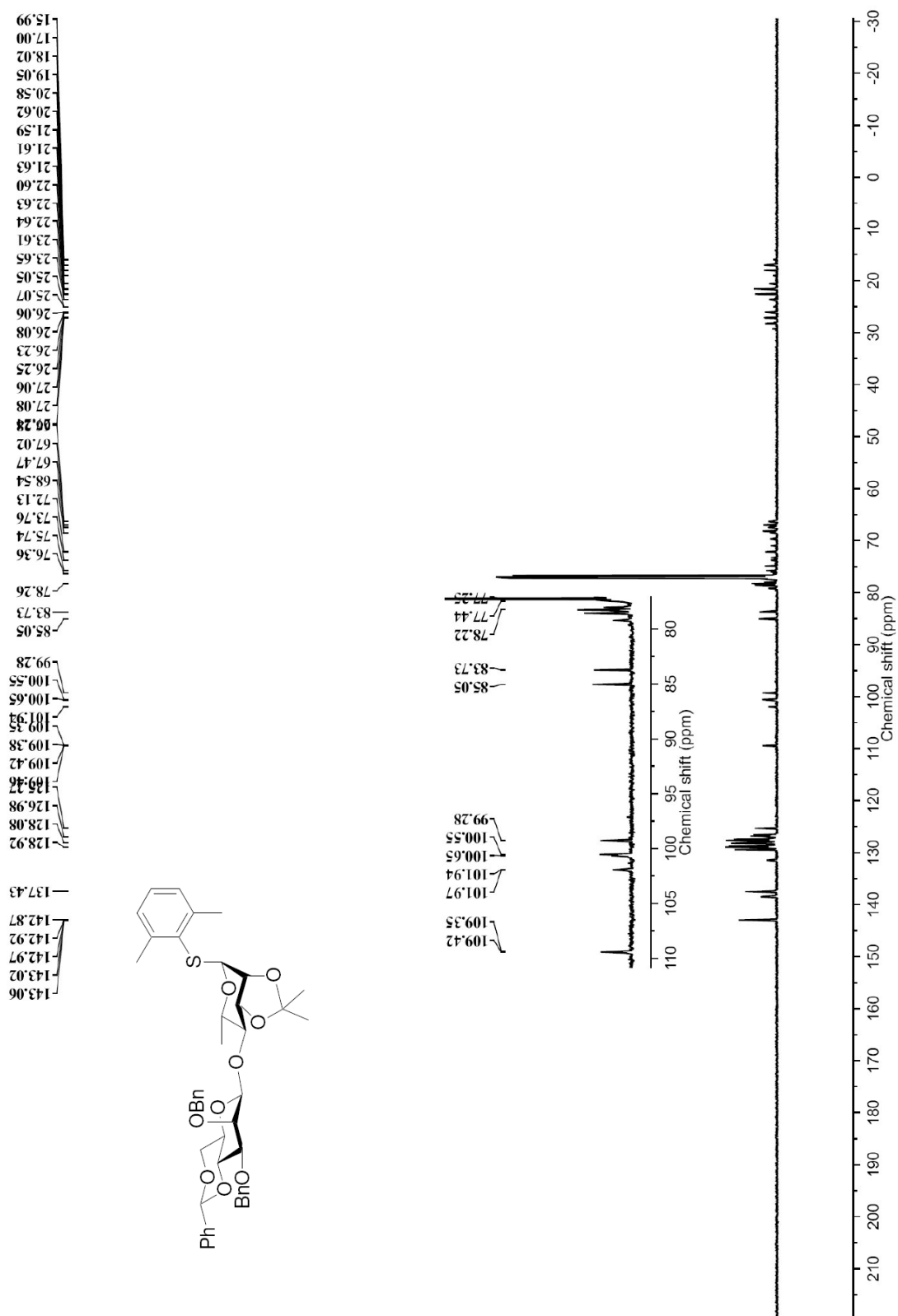

¹H NMR spectrum of (*p*-nitrophenyl) 2,3,4-tri-*O*-acetyl- α -L-fucopyranoside **27a**

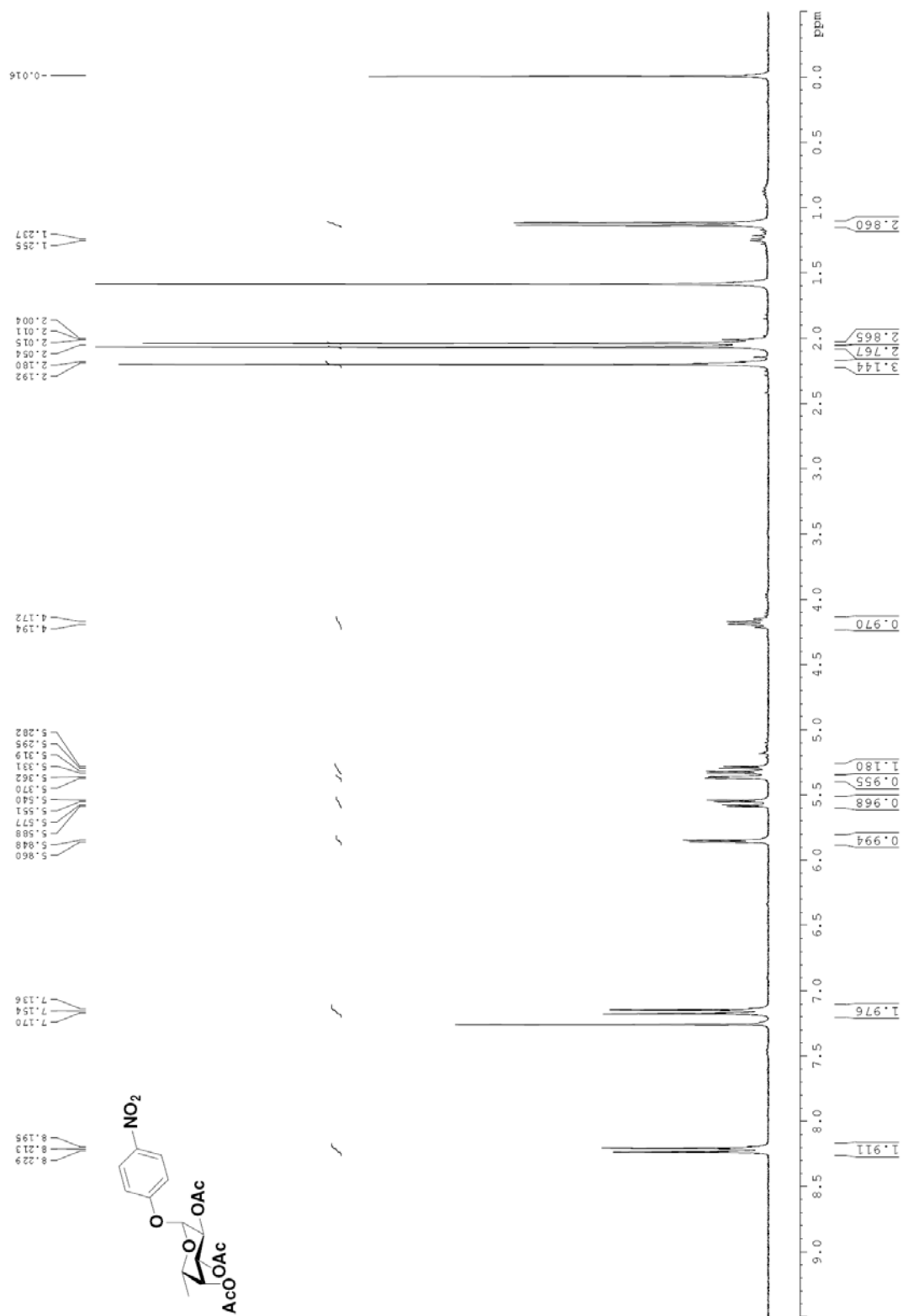

^{13}C NMR spectrum of (*p*-nitrophenyl) 2,3,4-tri-*O*-acetyl- α -L-fucopyranoside **27a**

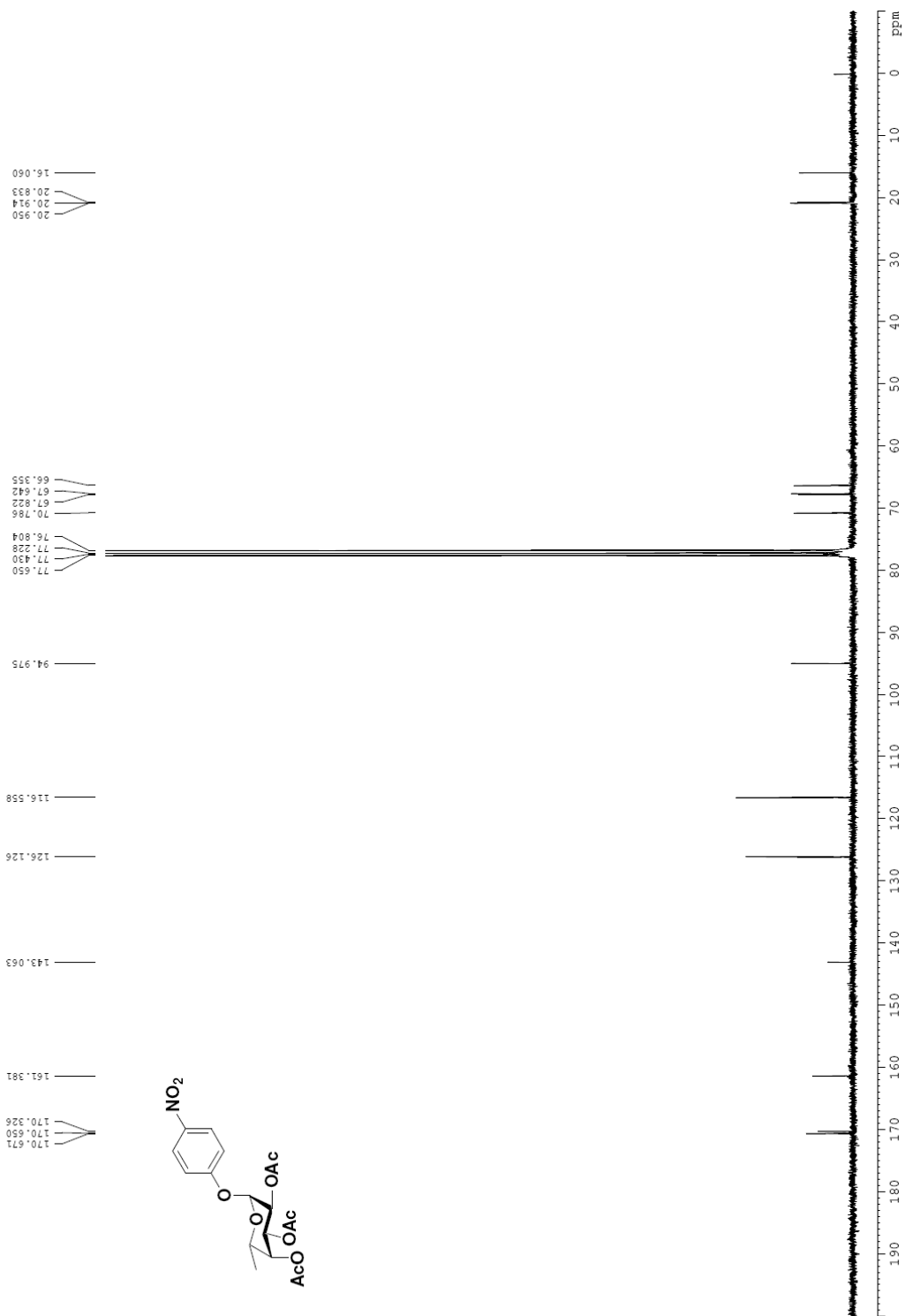

¹H NMR spectrum of (*p*-nitrophenyl) 2,3,4-tri-*O*-acetyl-β-L-fucopyranoside **27b**

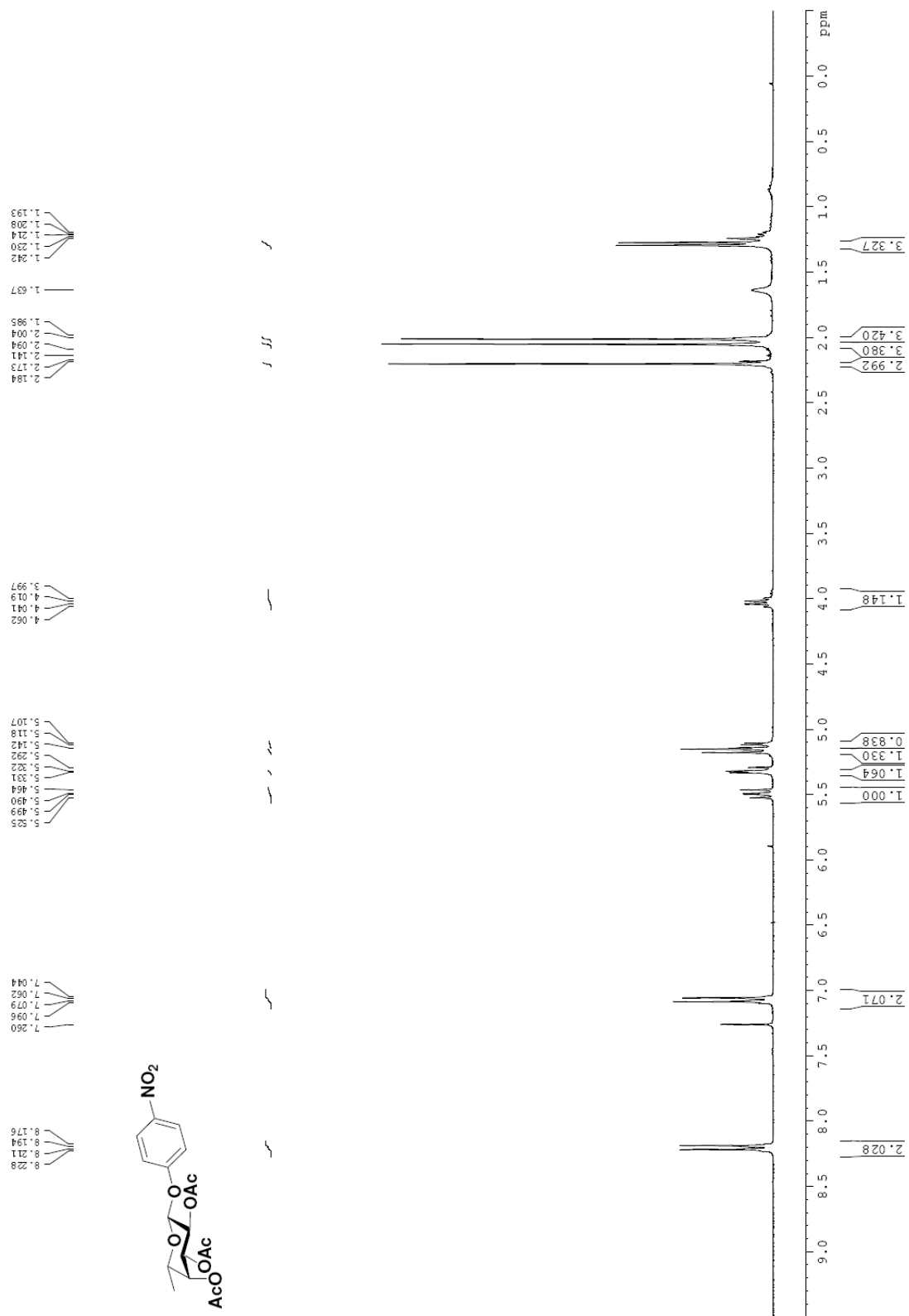

^{13}C NMR spectrum of (*p*-nitrophenyl) 2,3,4-tri-*O*-acetyl- β -L-fucopyranoside **27b**

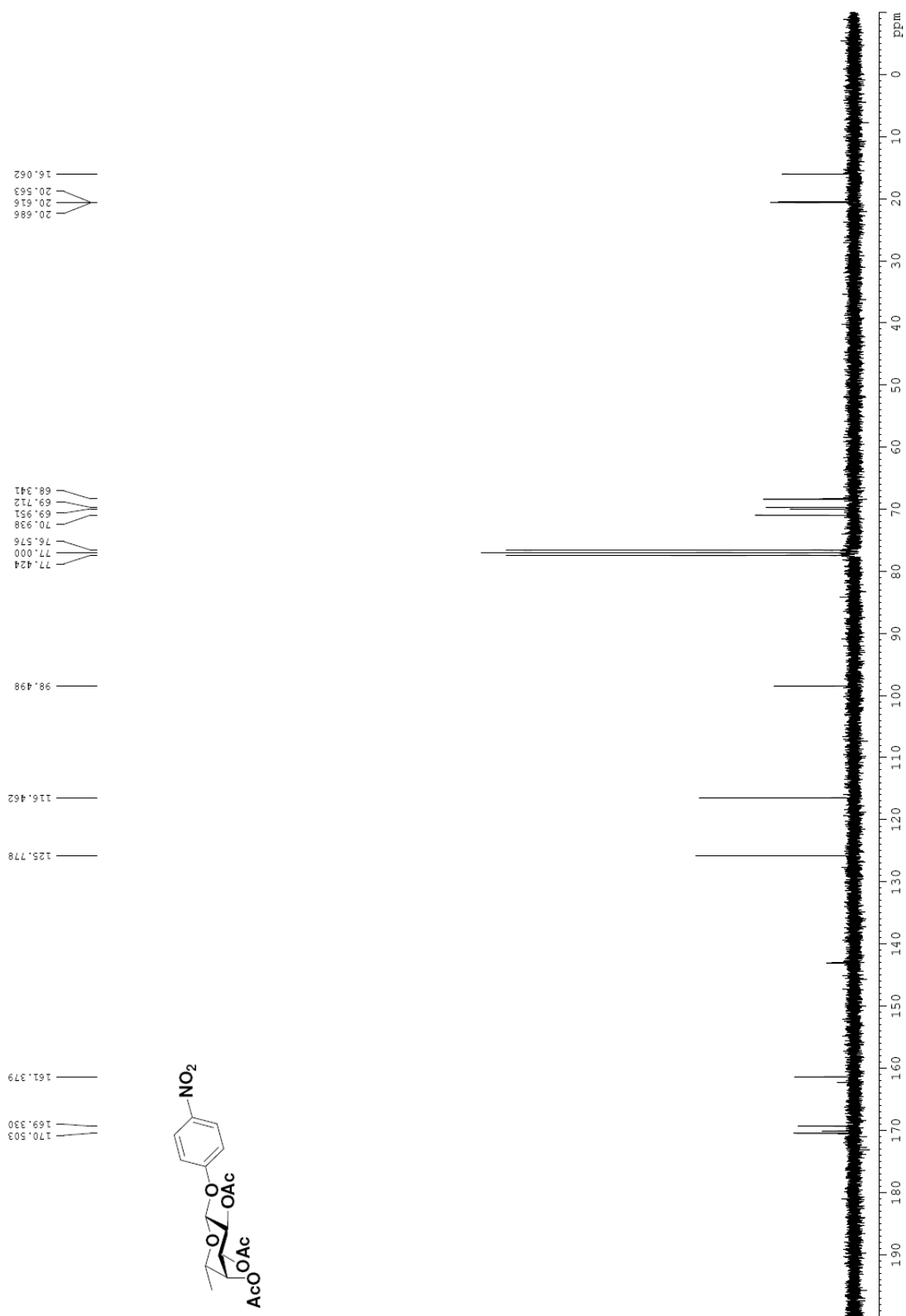

^1H NMR spectrum of (*m*-nitrophenyl) 2,3,4-tri-*O*-acetyl- α -L-fucopyranoside **38**

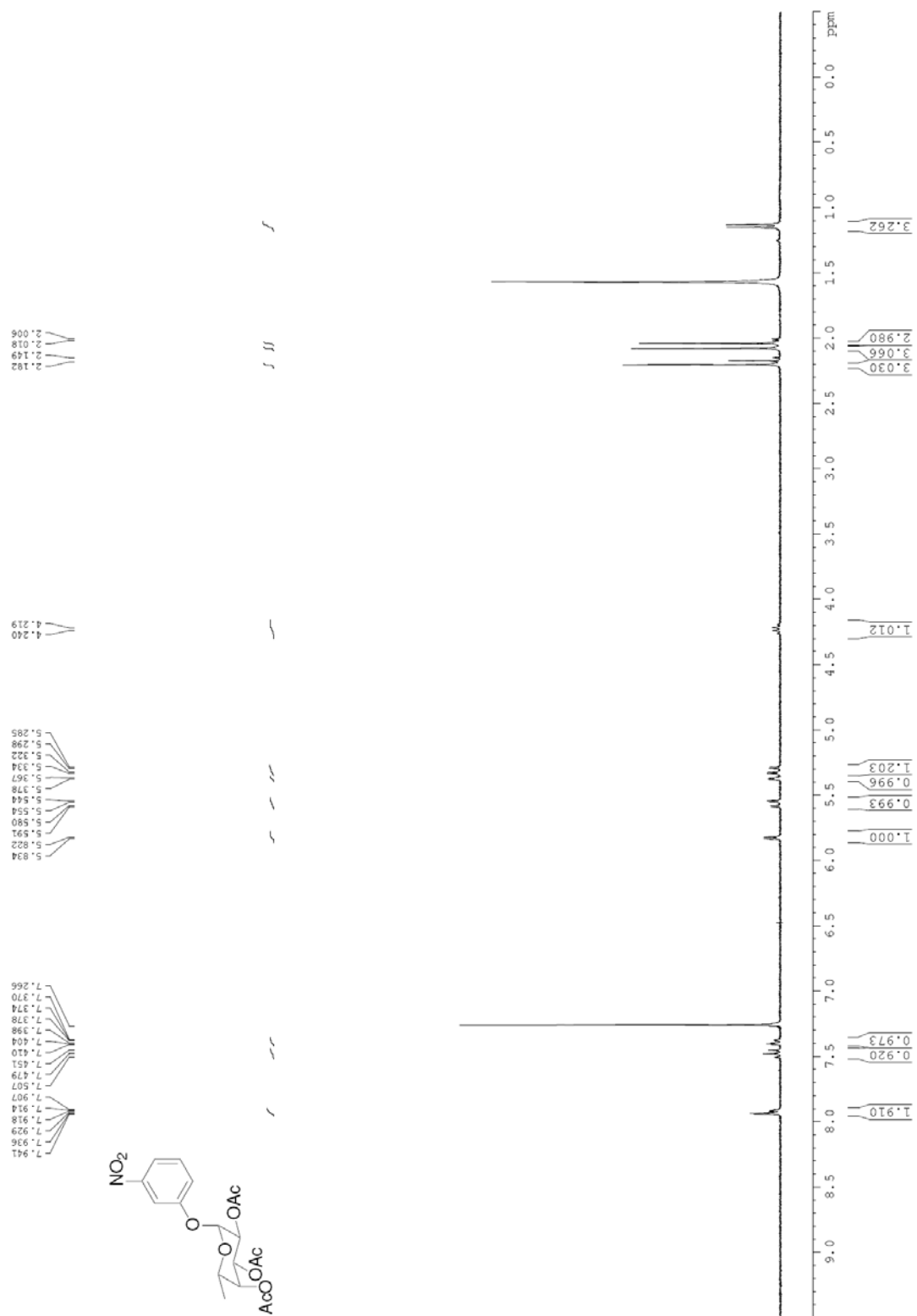

^{13}C NMR spectrum of (*m*-nitrophenyl) 2,3,4-tri-*O*-acetyl- α -L-fucopyranoside **38**

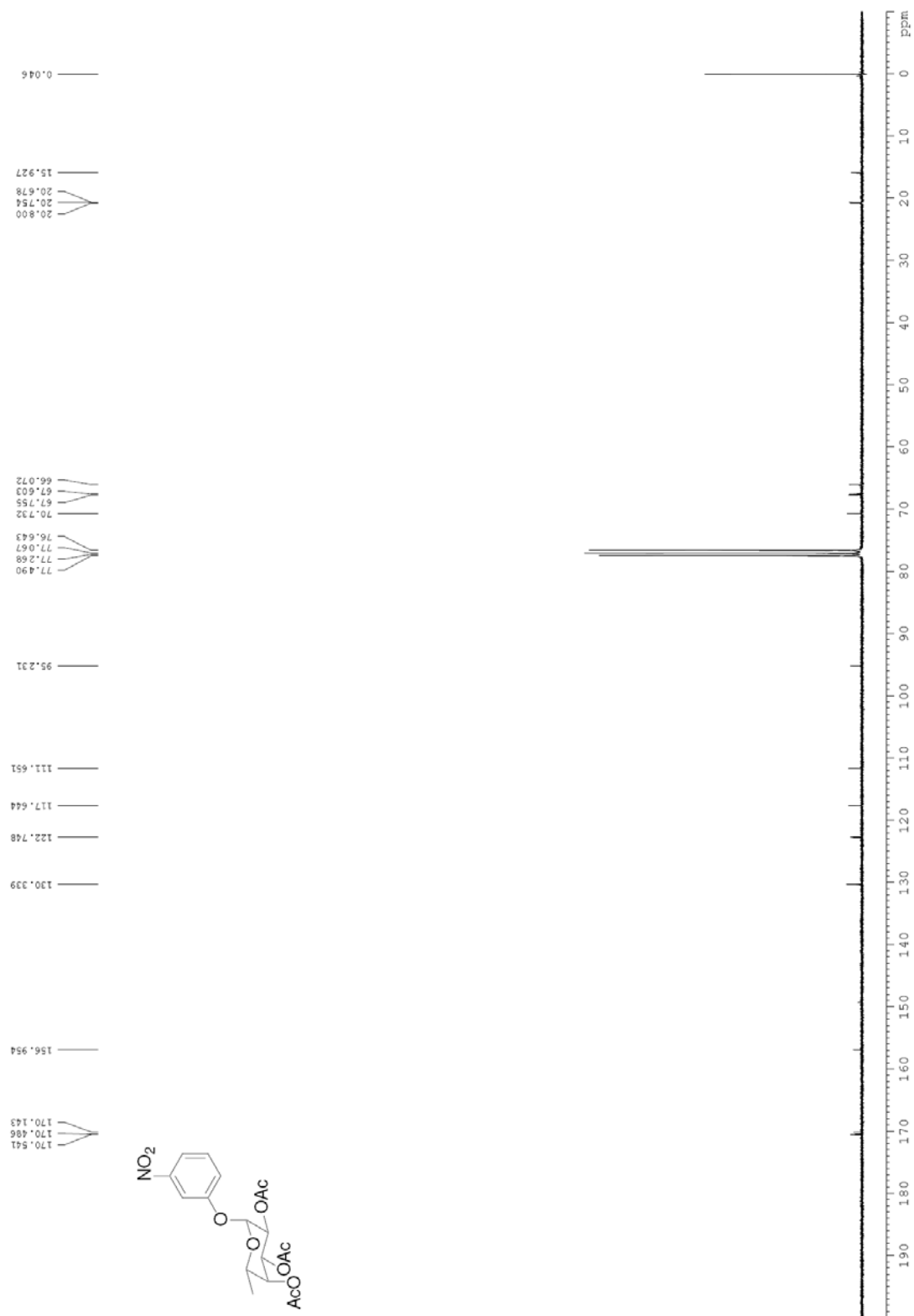

^1H MR spectrum of (*p*-cyanophenyl) 2,3,4-tri-*O*-acetyl- α -L-fucopyranoside **39**

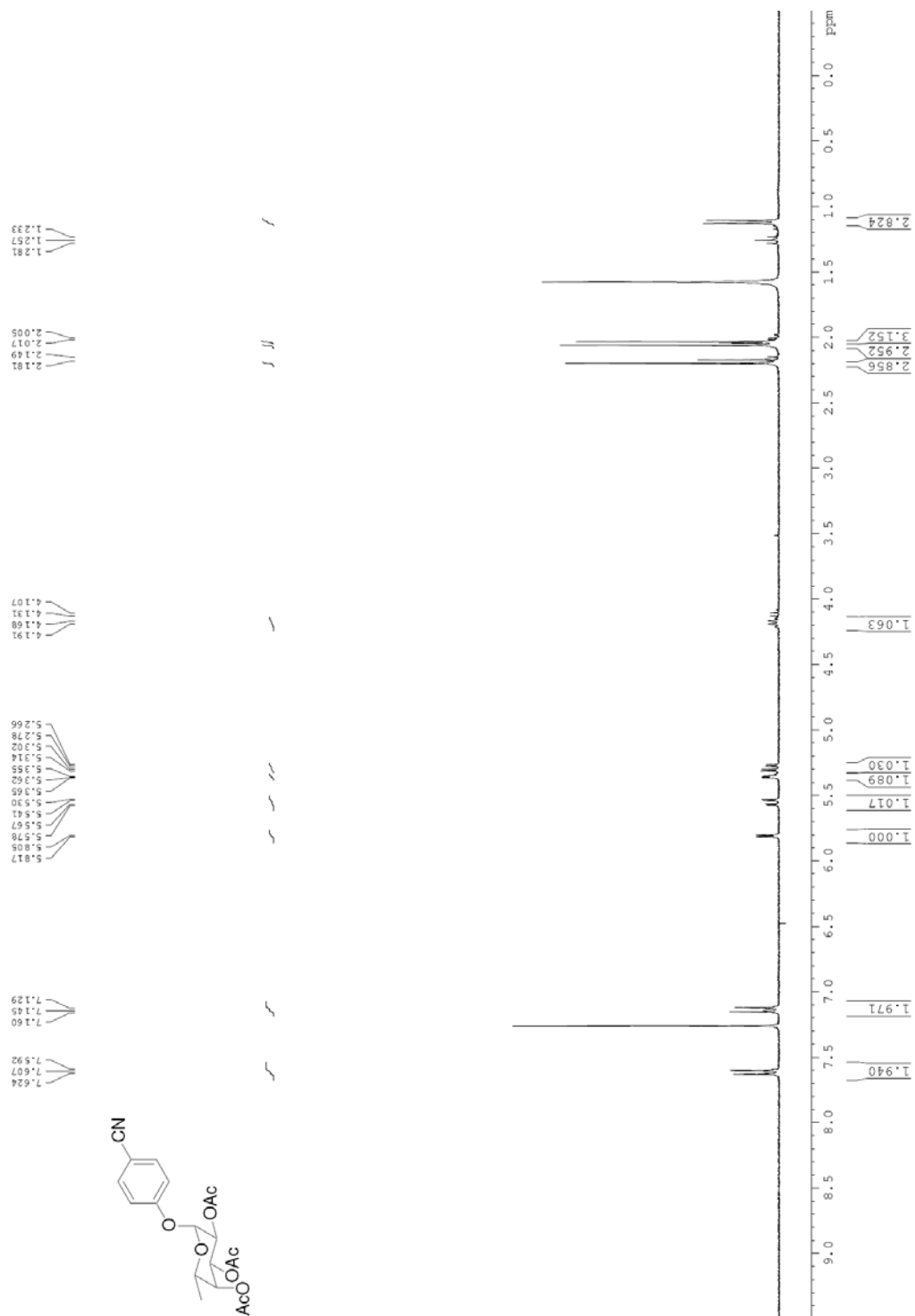

^{13}C NMR spectrum of (*p*-cyanophenyl) 2,3,4-tri-*O*-acetyl- α -L-fucopyranoside **39**

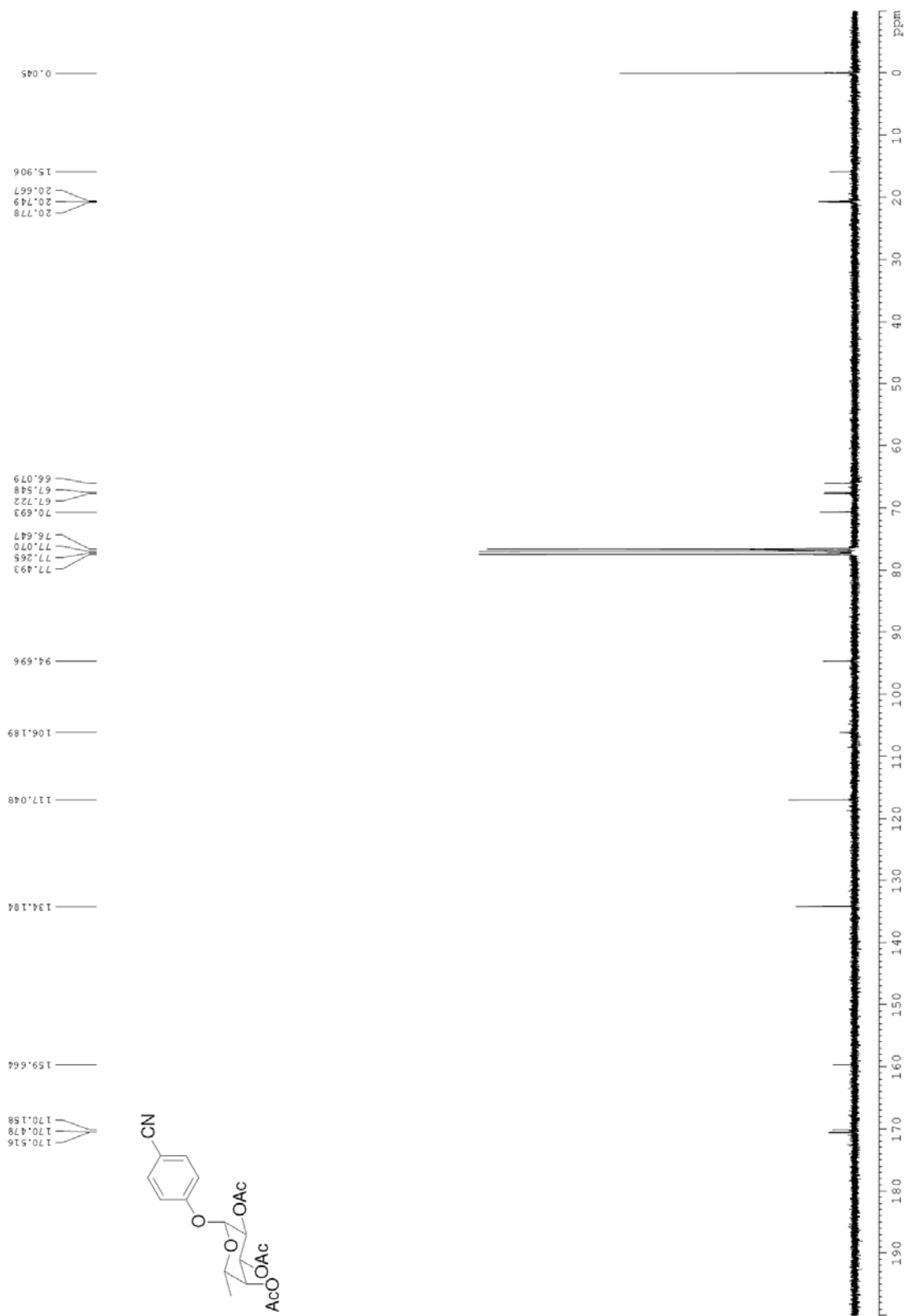

¹H MR spectrum of phenyl 2,3,4-tri-*O*-acetyl- α -L-fucopyranoside **40**

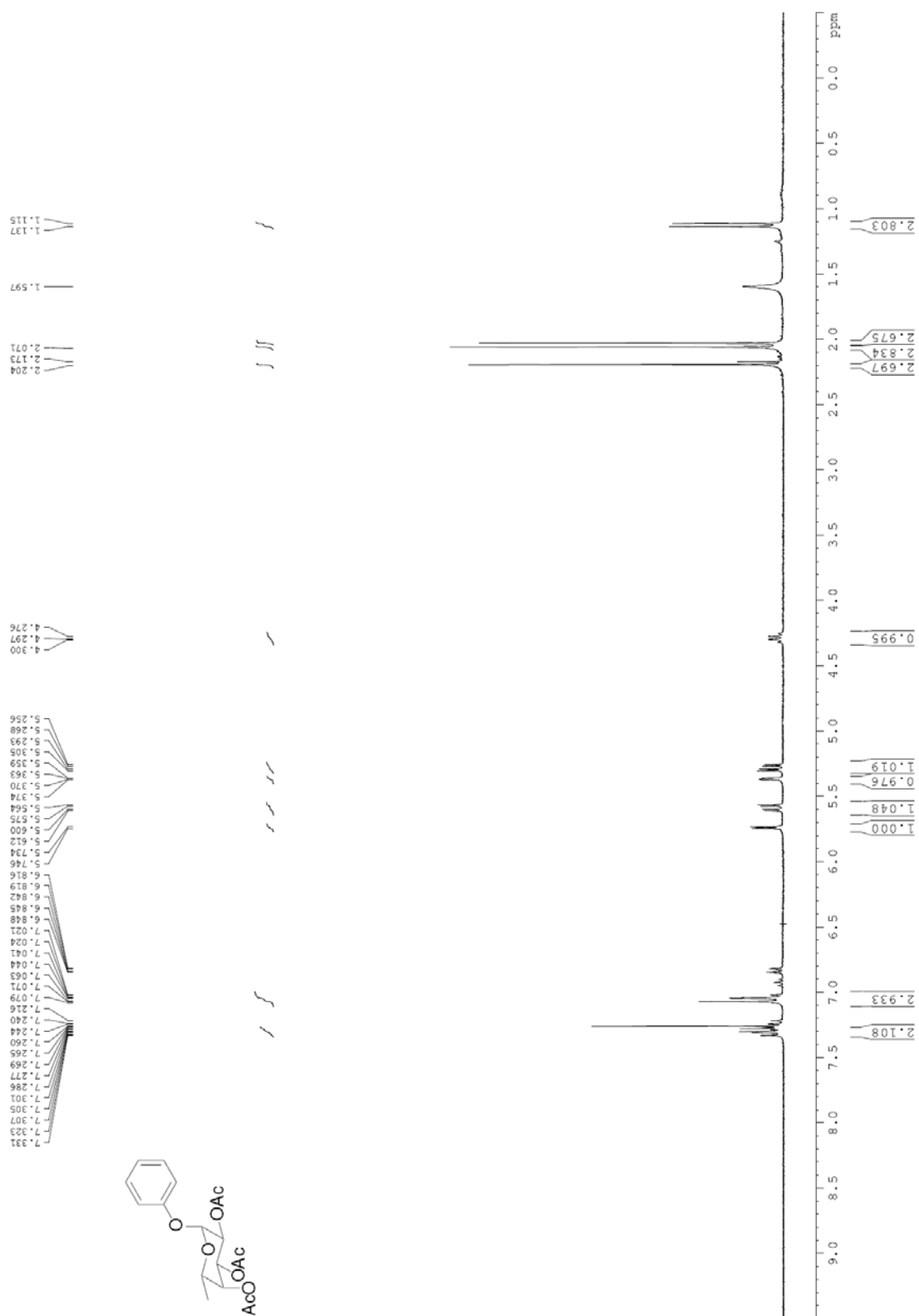

^{13}C MR spectrum of phenyl 2,3,4-tri-*O*-acetyl- α -L-fucopyranoside **40**

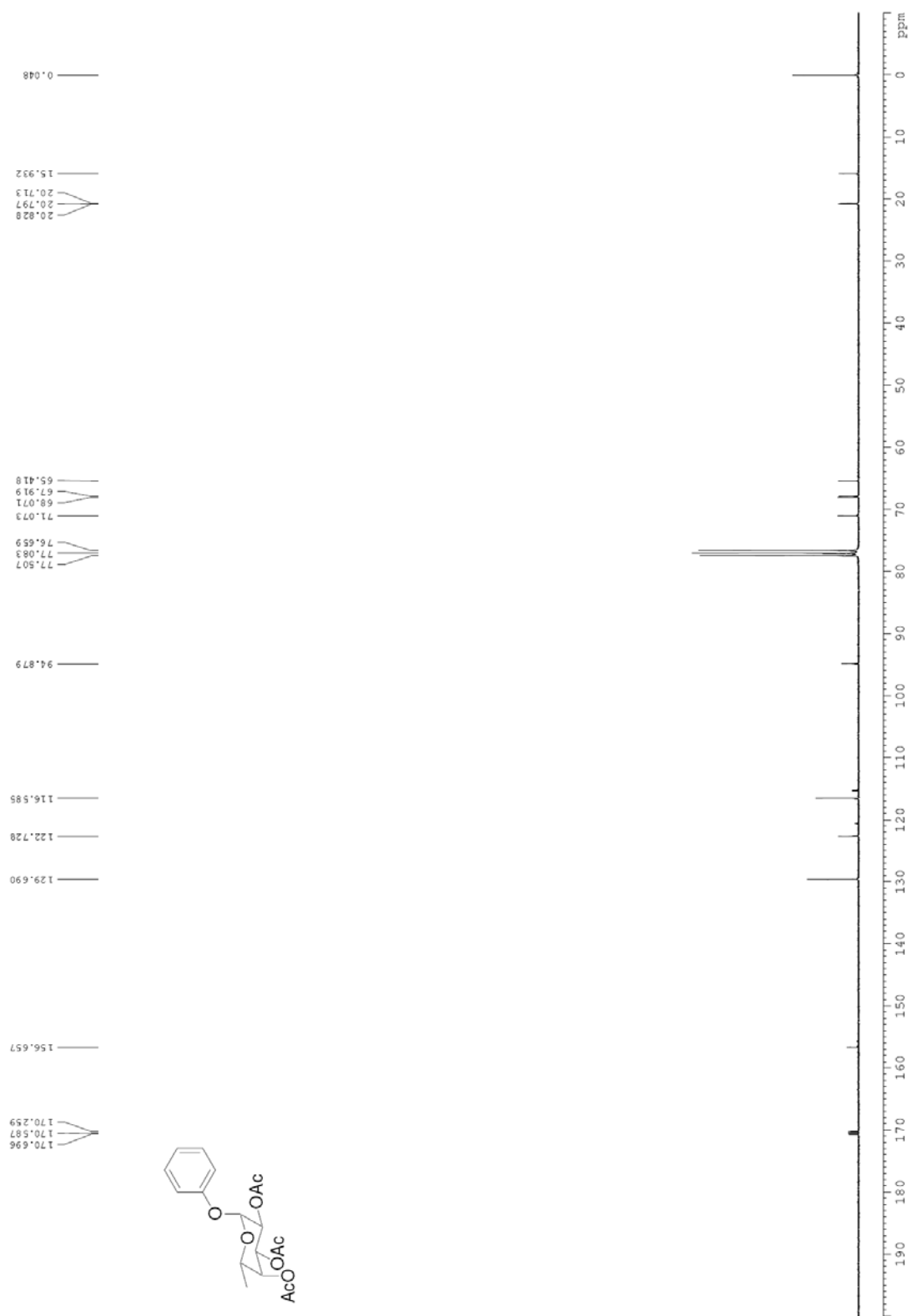

¹H NMR spectrum of (2-fluoro-4-nitrophenyl) 2,3,4-tri-*O*-acetyl- α -L-fucopyranoside **41**

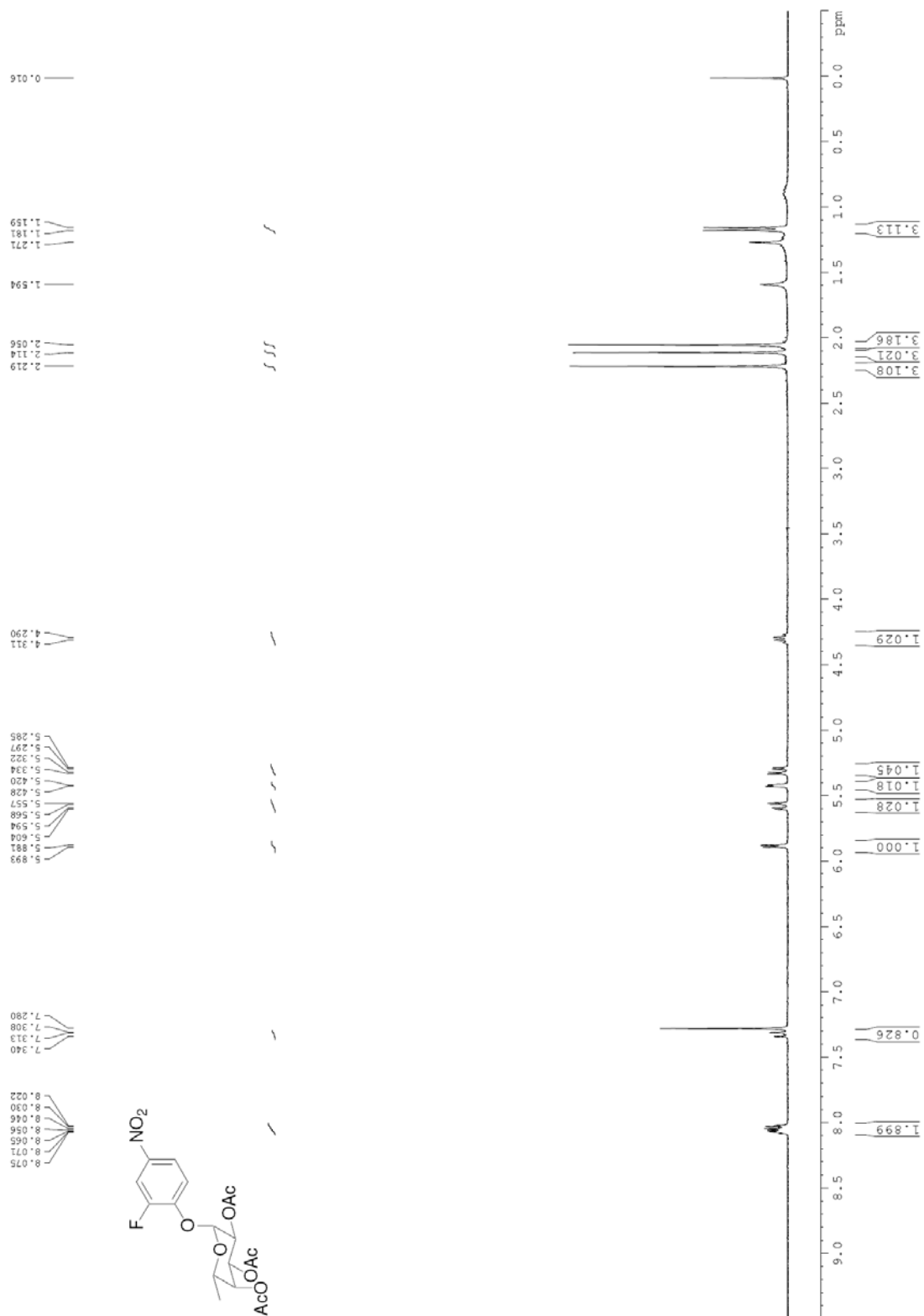

^{13}C NMR spectrum of (2-fluoro-4-nitrophenyl) 2,3,4-tri-*O*-acetyl- α -L-fucopyranoside **41**

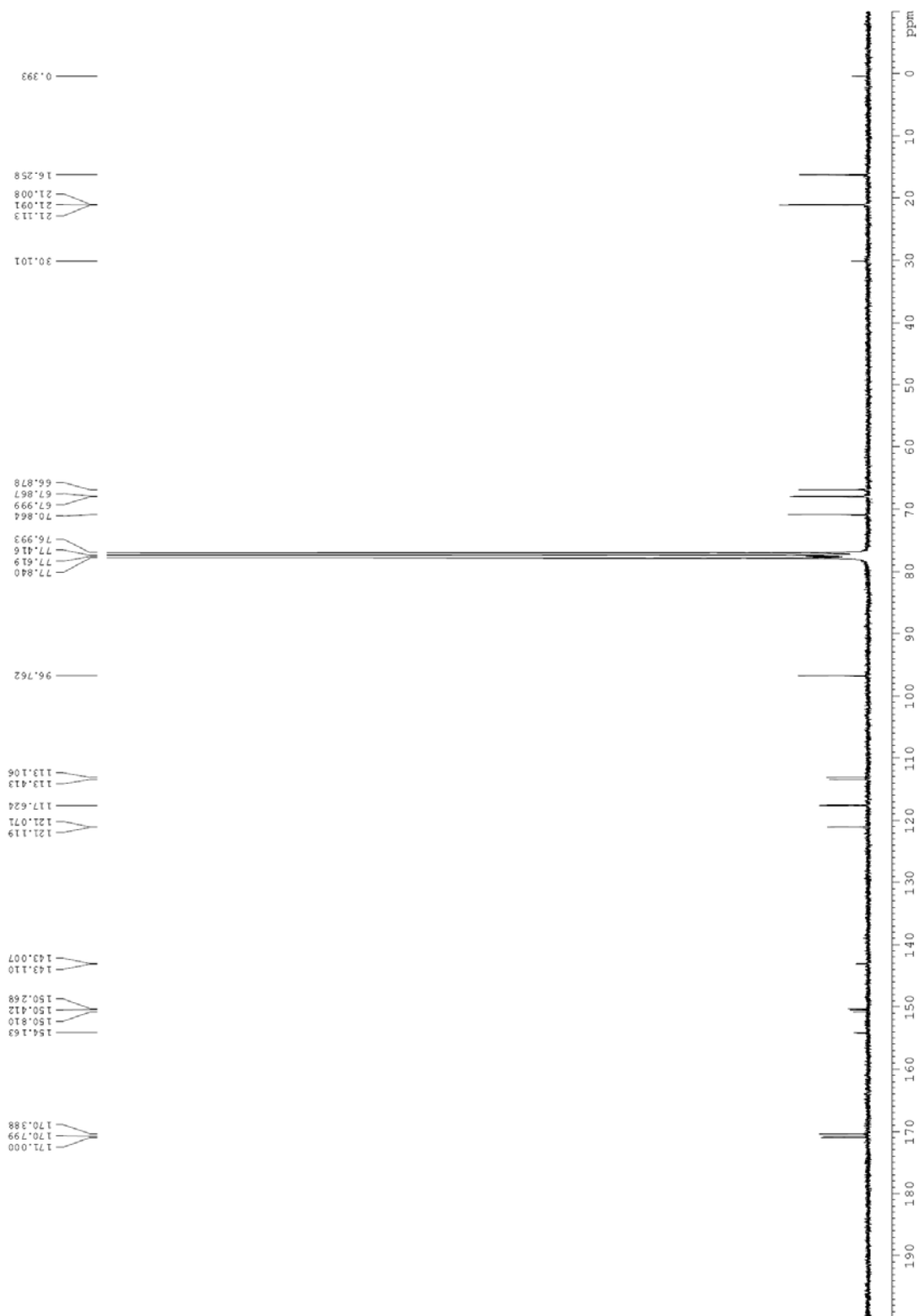

¹H NMR spectrum of (3,4-dinitrophenyl) 2,3,4-tri-*O*-acetyl- α -L-fucopyranoside **42**

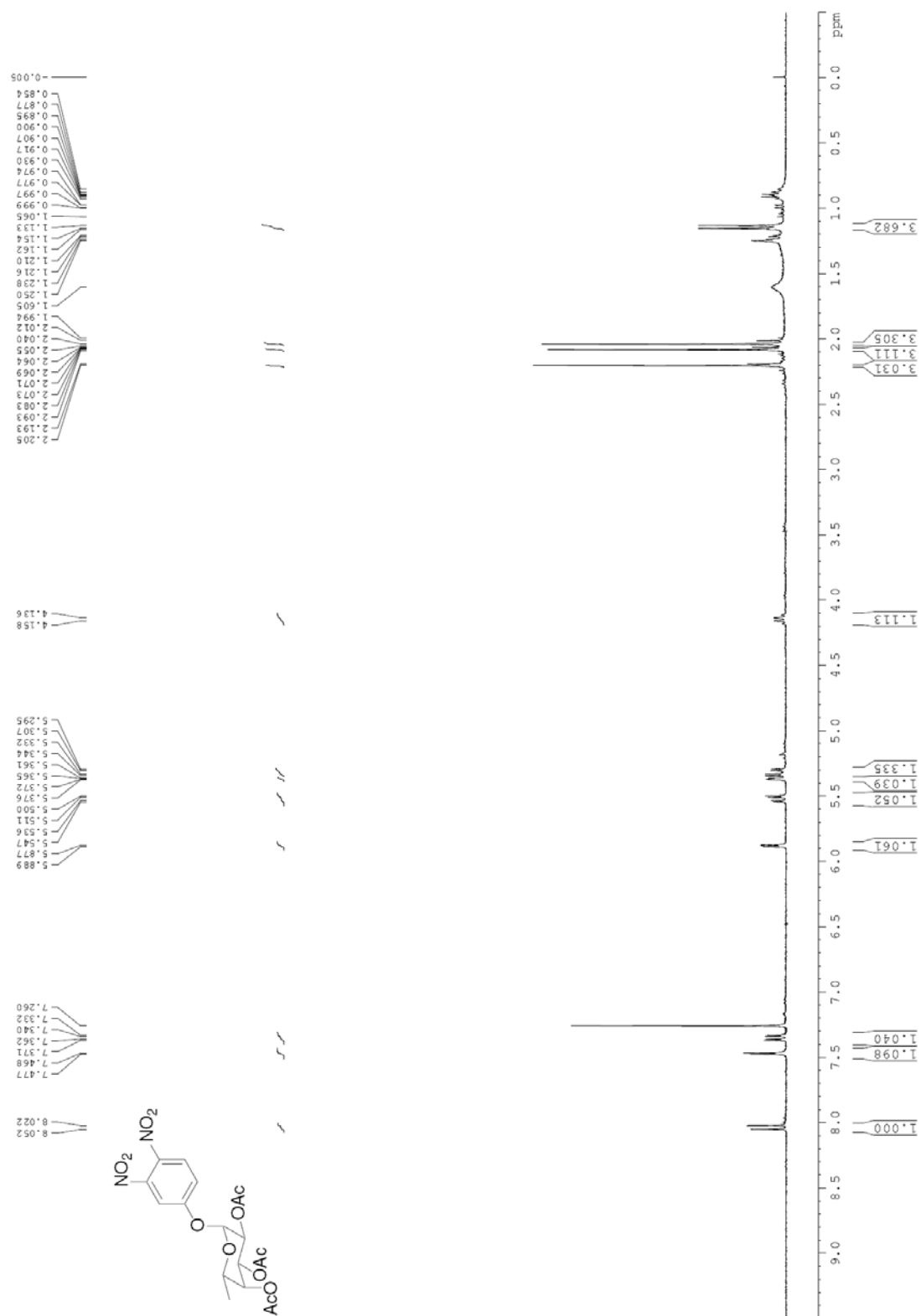

^{13}C NMR spectrum of (3,4-dinitrophenyl) 2,3,4-tri-*O*-acetyl- α -L-fucopyranoside **42**

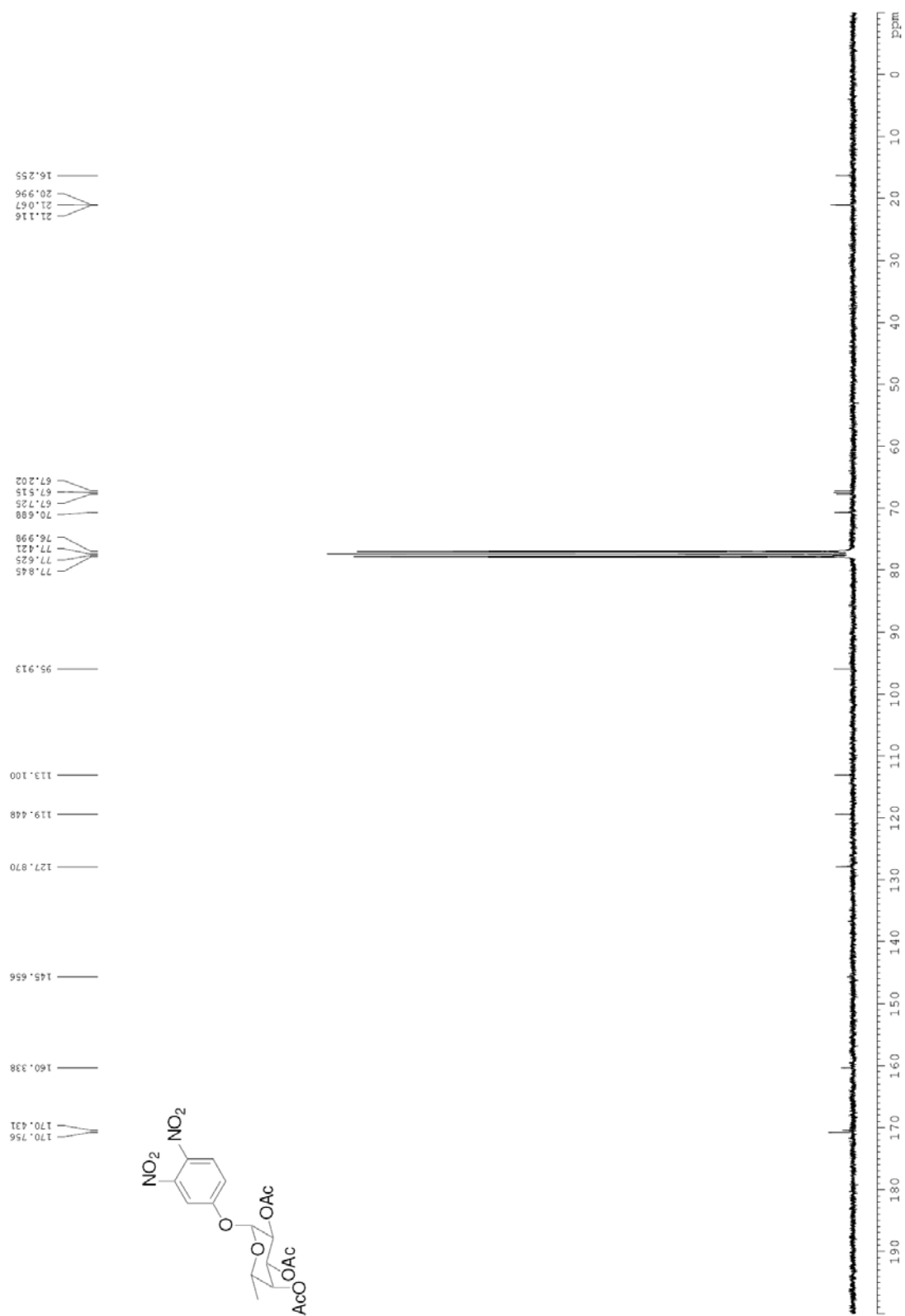

¹H NMR spectrum of (4-methylumbelliferyl) 2,3,4-tri-*O*-acetyl- α -L-fucopyranoside **43**

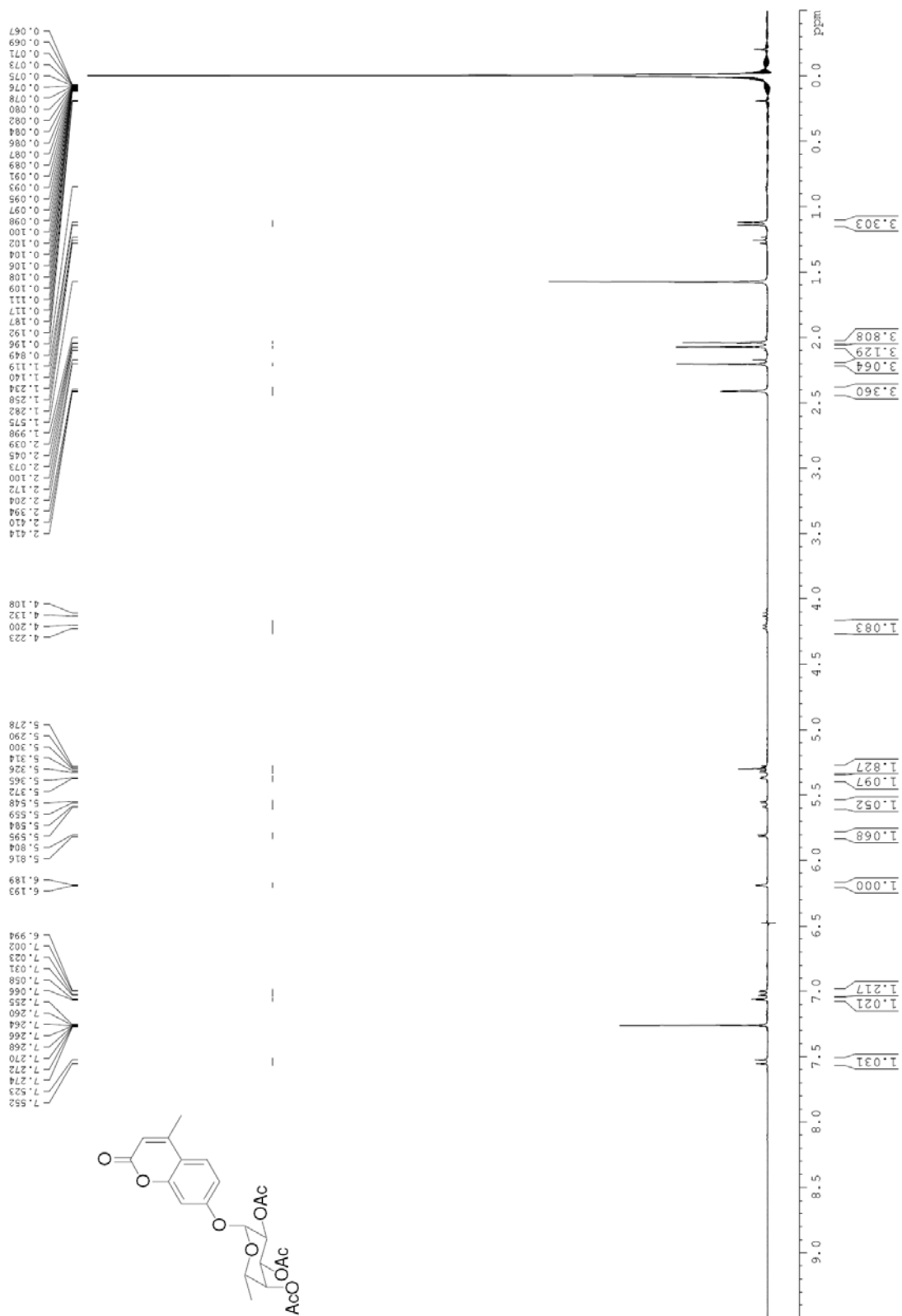

^{13}C NMR spectrum of (4-methylumbelliferyl) 2,3,4-tri-*O*-acetyl- α -L-fucopyranoside **43**

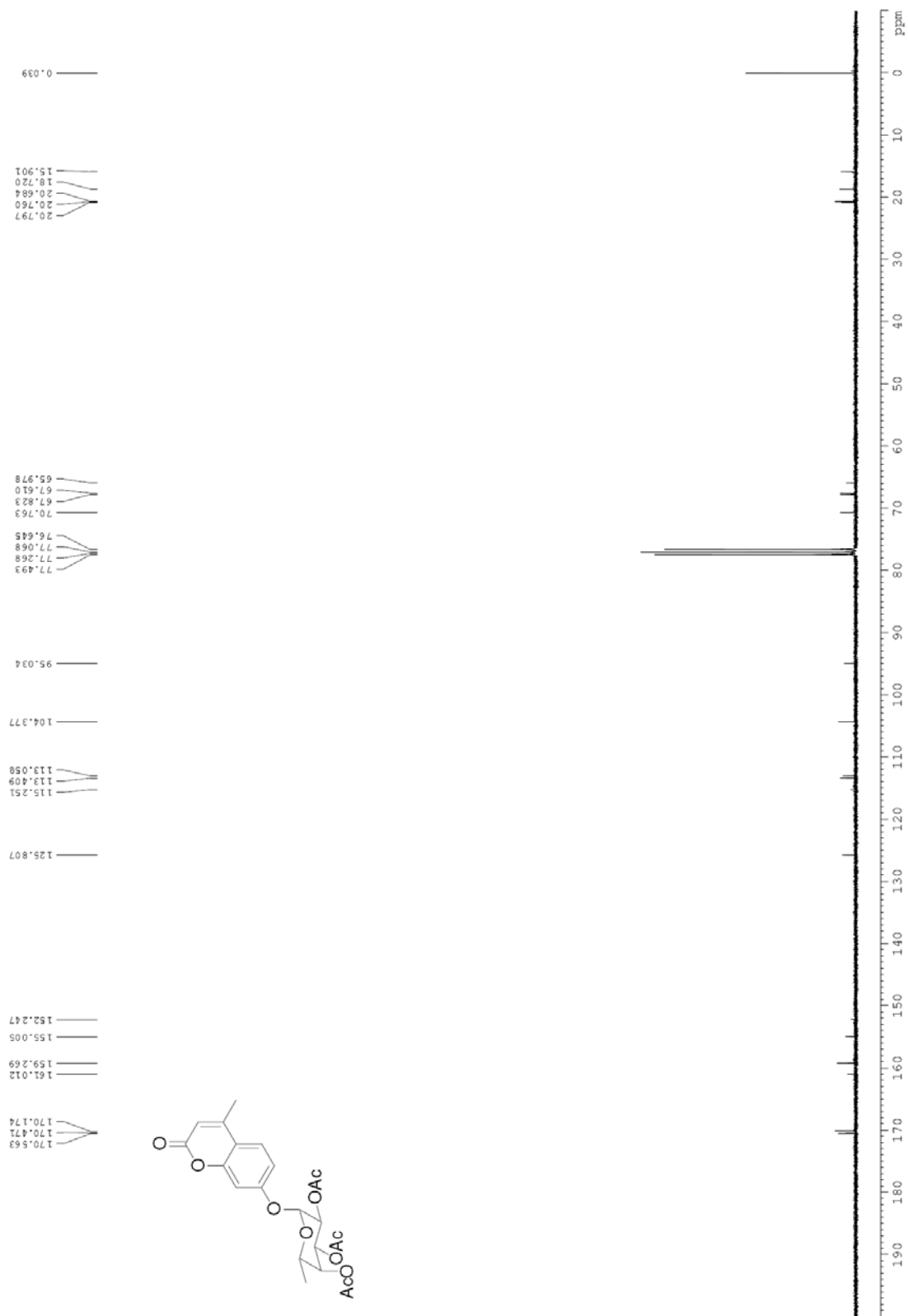

¹H NMR spectrum of (2-naphthyl) 2,3,4-tri-*O*-acetyl- α -L-fucopyranoside
44

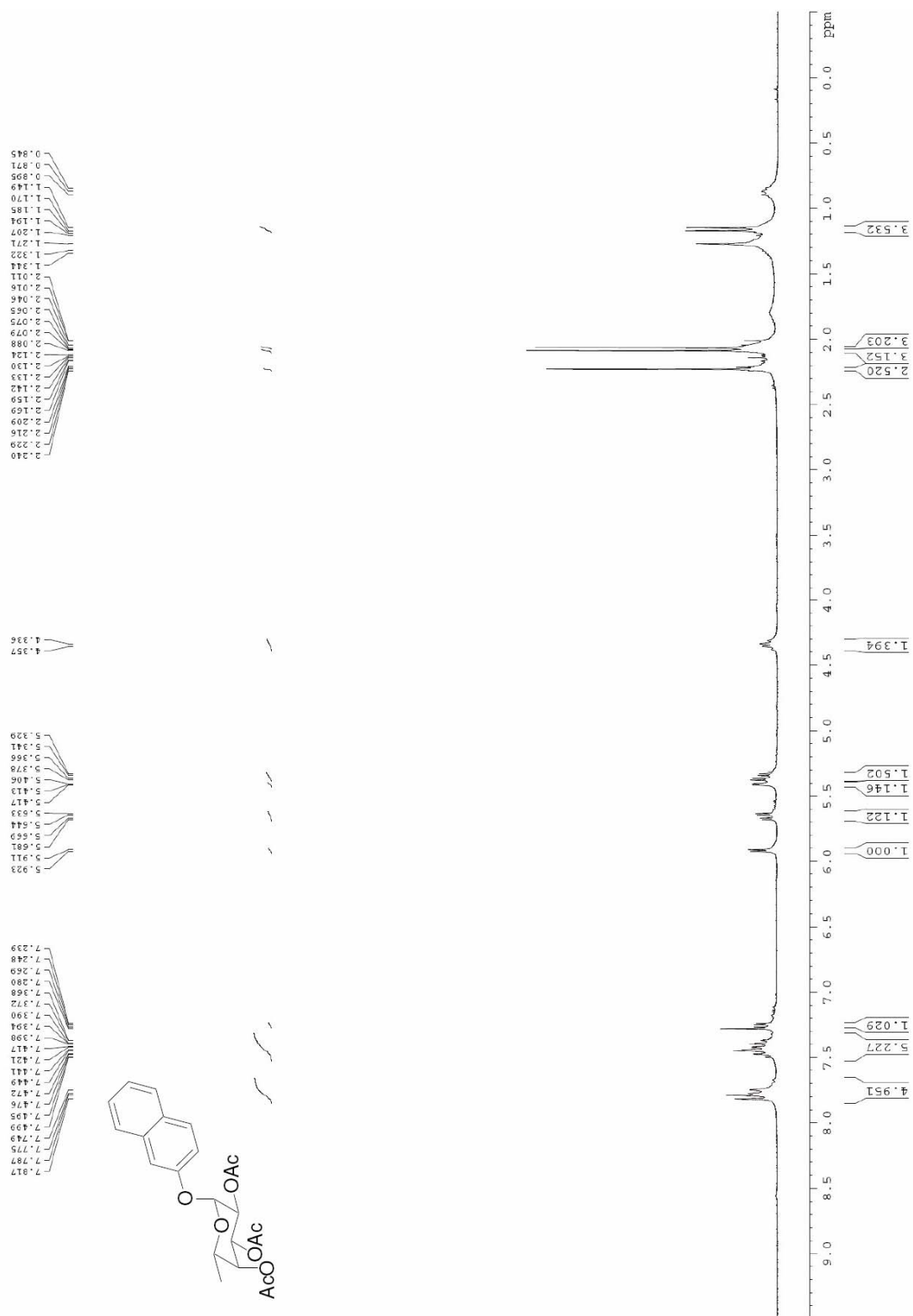

¹³C NMR spectrum of (2-naphthyl) 2,3,4-tri-*O*-acetyl- α -L-fucopyranoside
44

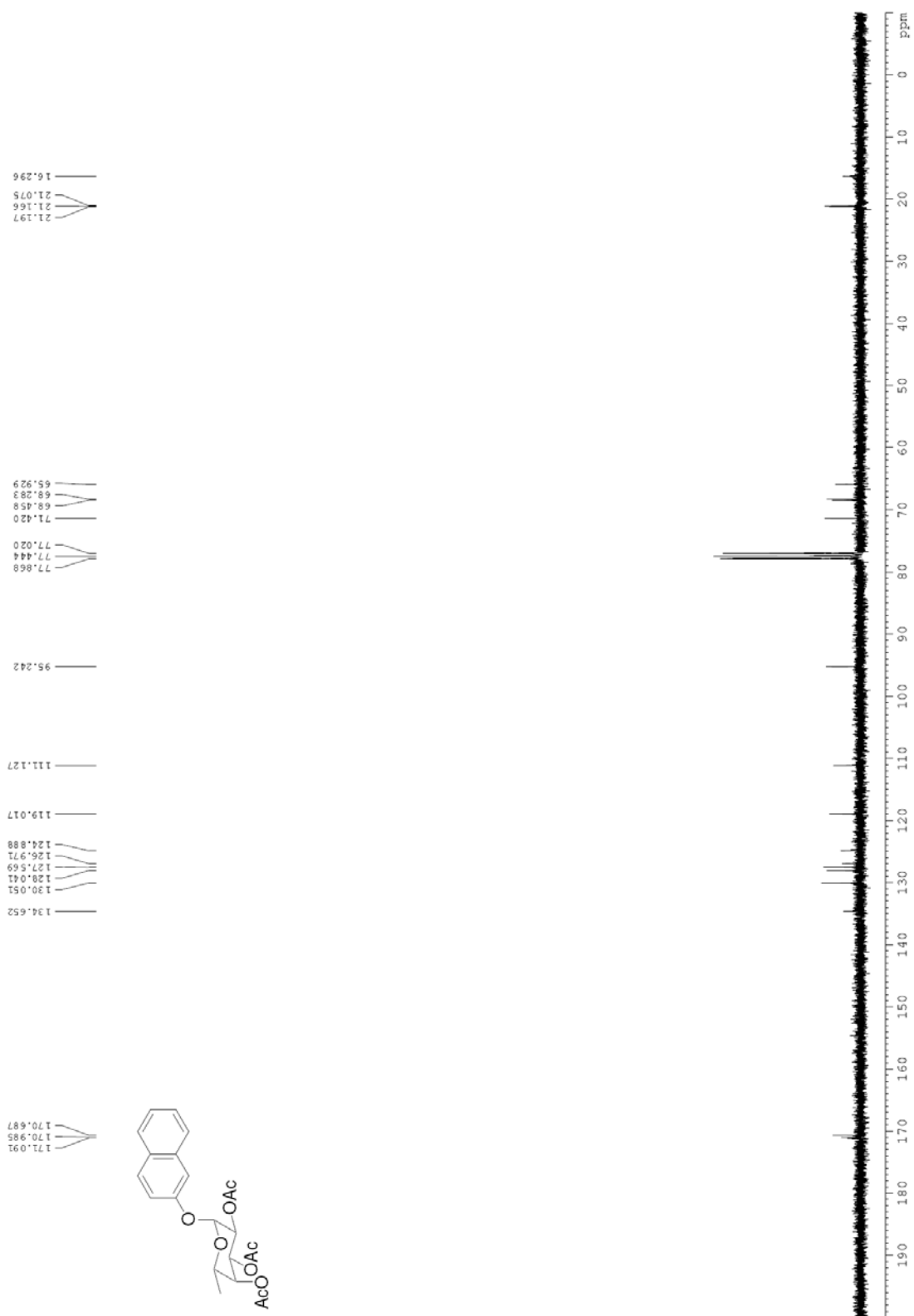

^1H NMR spectrum of *p*-nitrophenyl 2,3,4,6-tetra-*O*-acetyl- α -D-glucopyranoside **51 α**

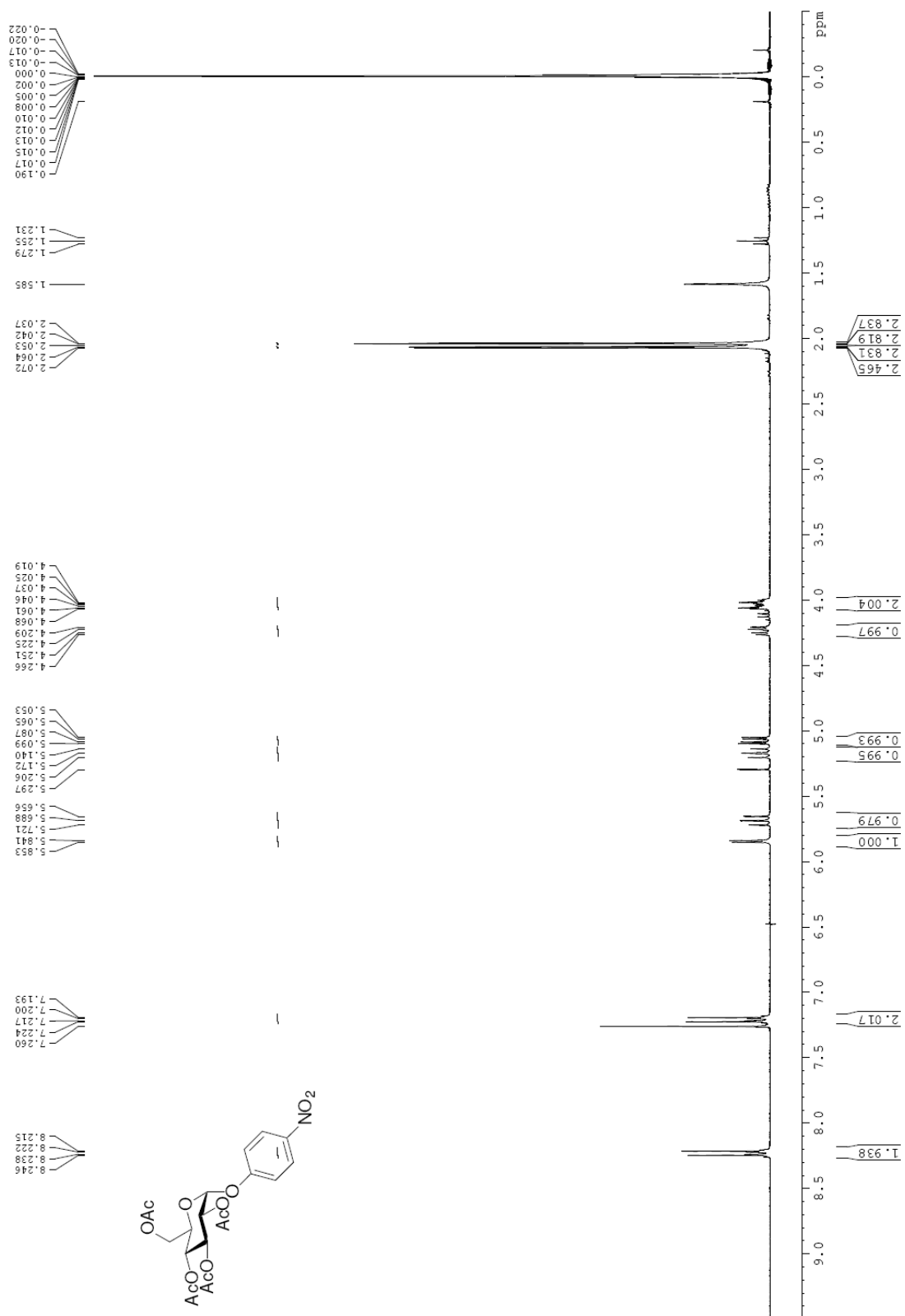

^{13}C NMR spectrum of *p*-nitrophenyl 2,3,4,6-tetra-*O*-acetyl- α -D-glucopyranoside **51a**

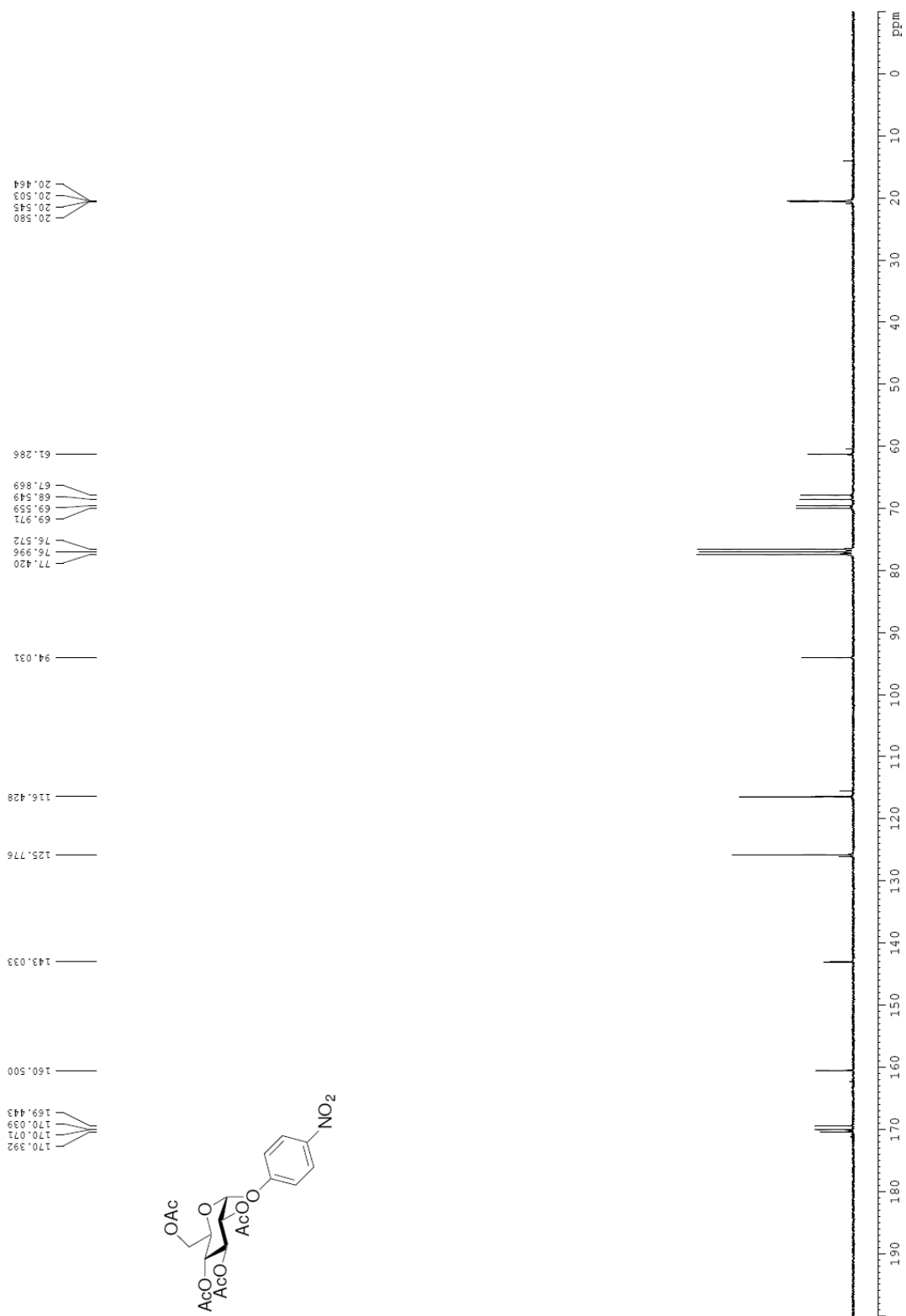

^1H NMR spectrum of (*p*-nitrophenyl) 2,3,4,6-tetra-*O*-acetyl- β -D-glucopyranoside **51 β**

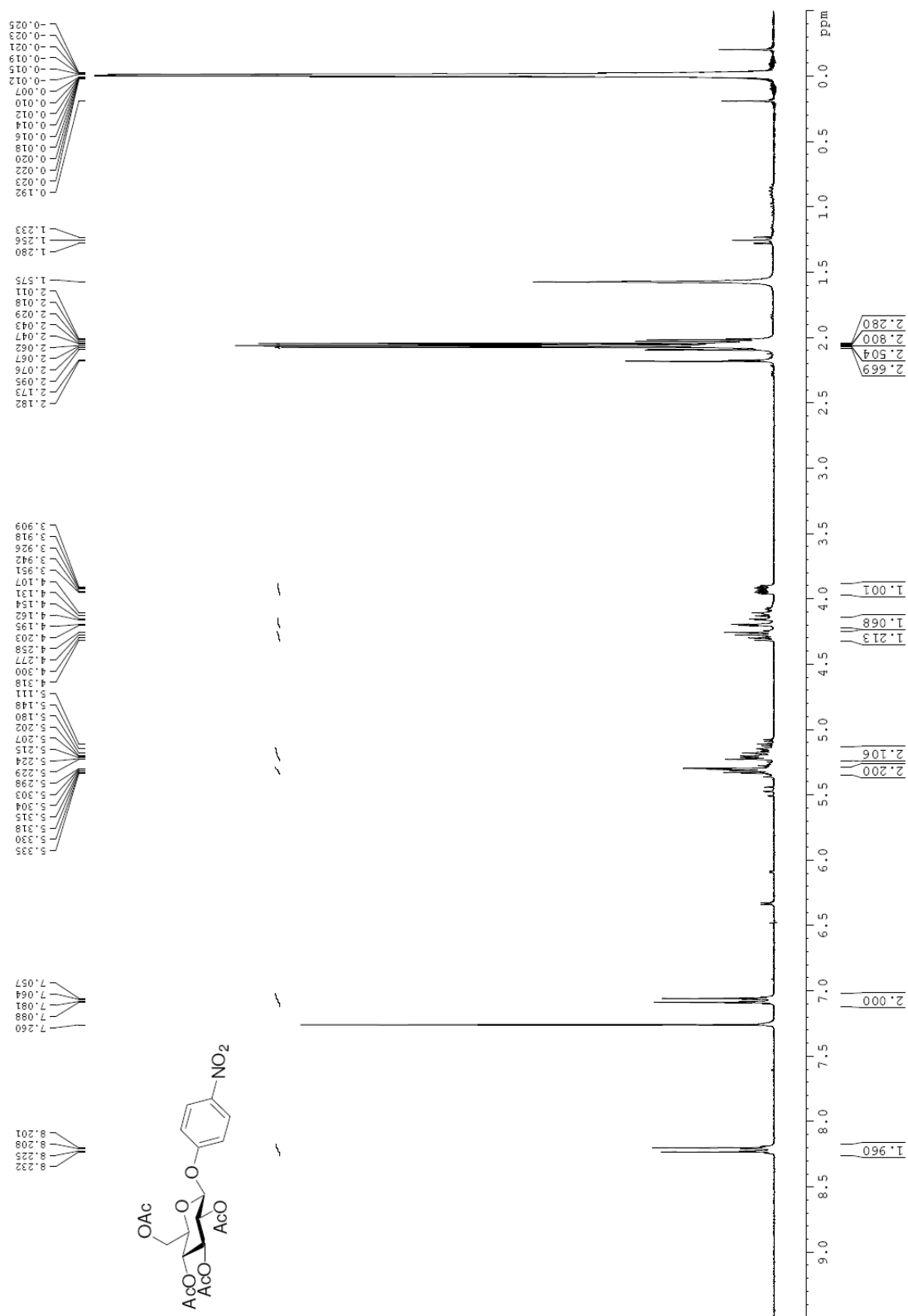

^{13}C NMR spectrum of (*p*-nitrophenyl) 2,3,4,6-tetra-*O*-acetyl- β -D-glucopyranoside **51 β**

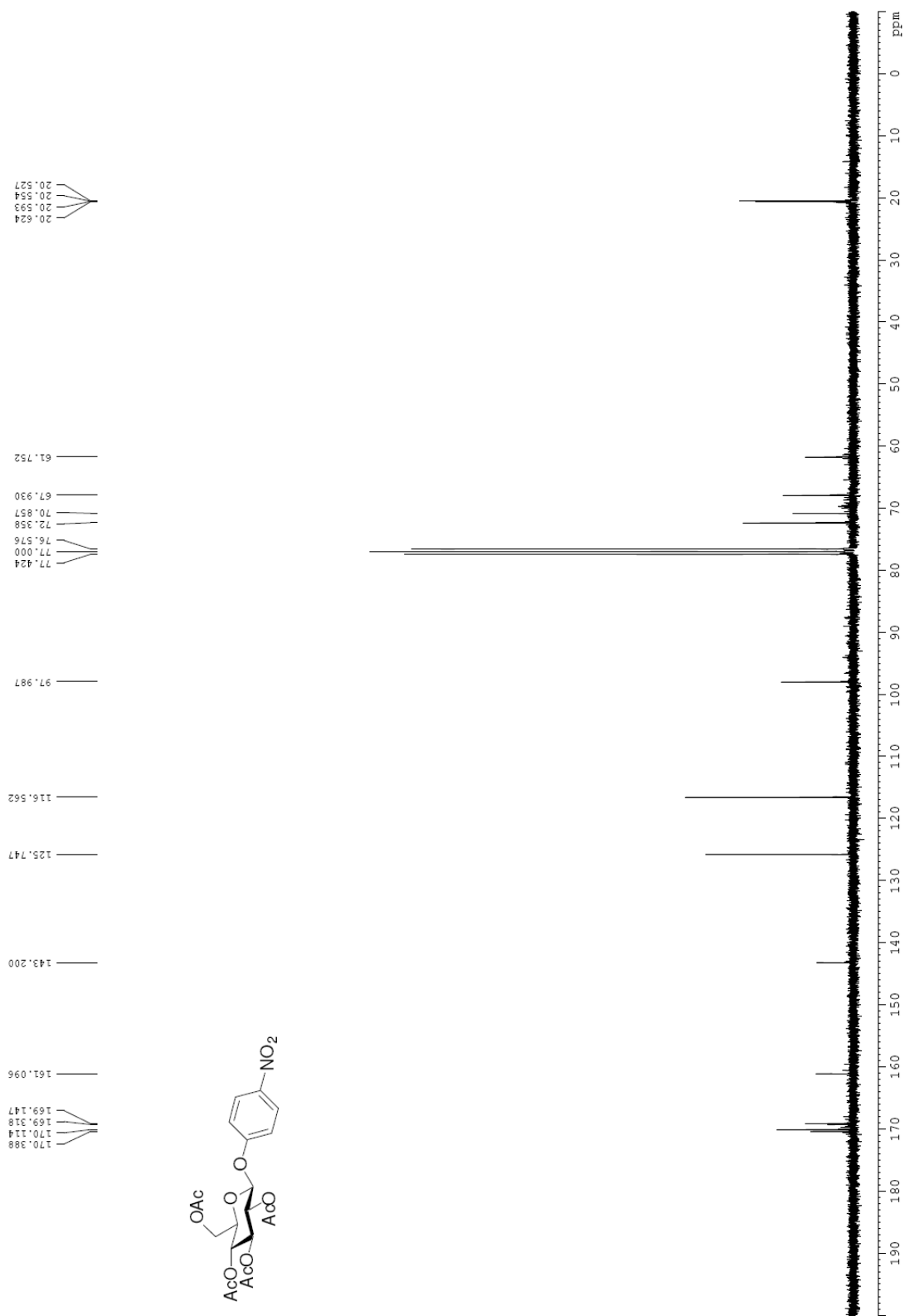

^1H NMR spectrum of (*p*-nitrophenyl) 2-azido-2-deoxy- α -D-galactopyranoside **53**

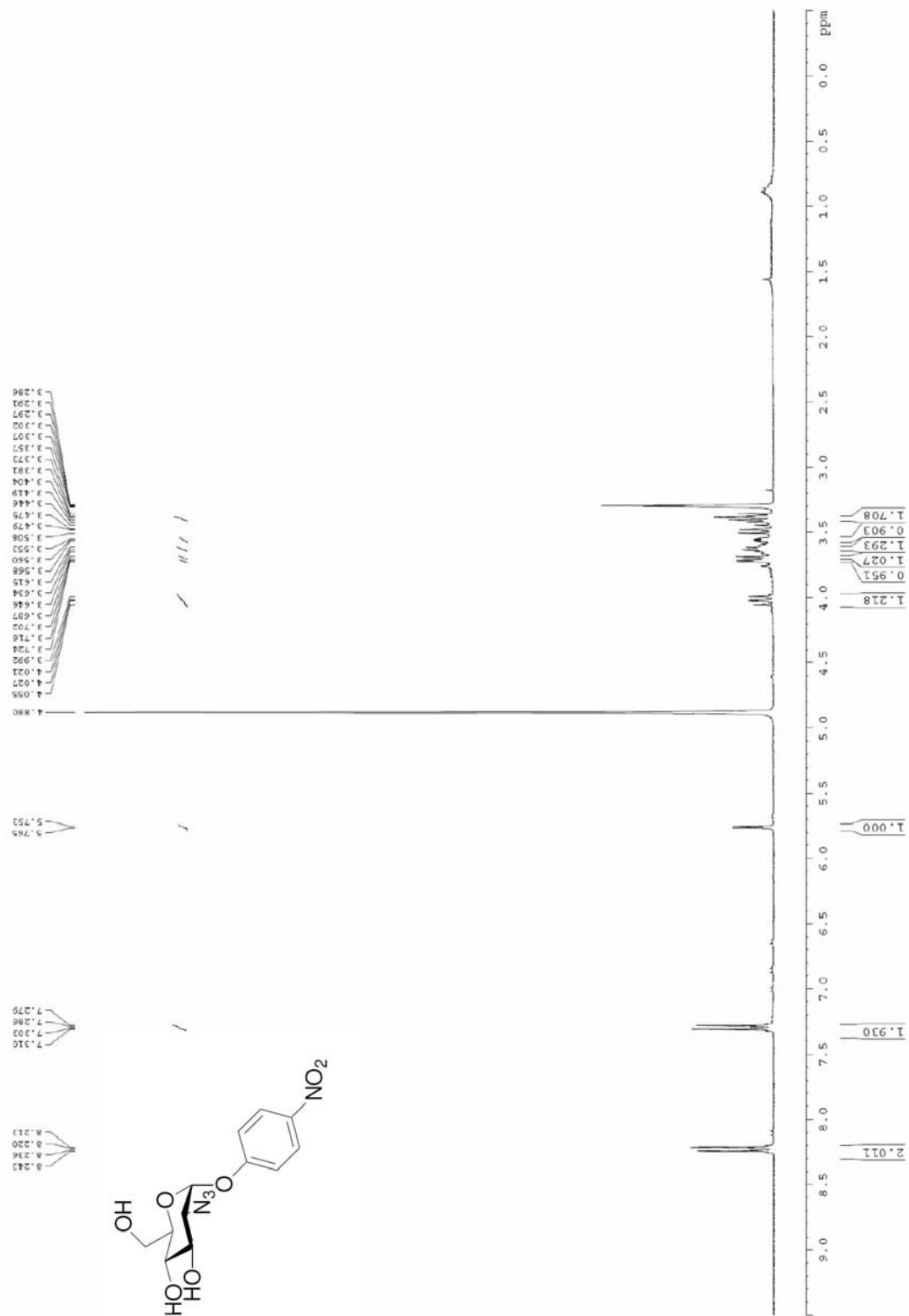

^{13}C NMR spectrum of (*p*-nitrophenyl) 2-azido-2-deoxy- α -D-galactopyranoside **53**

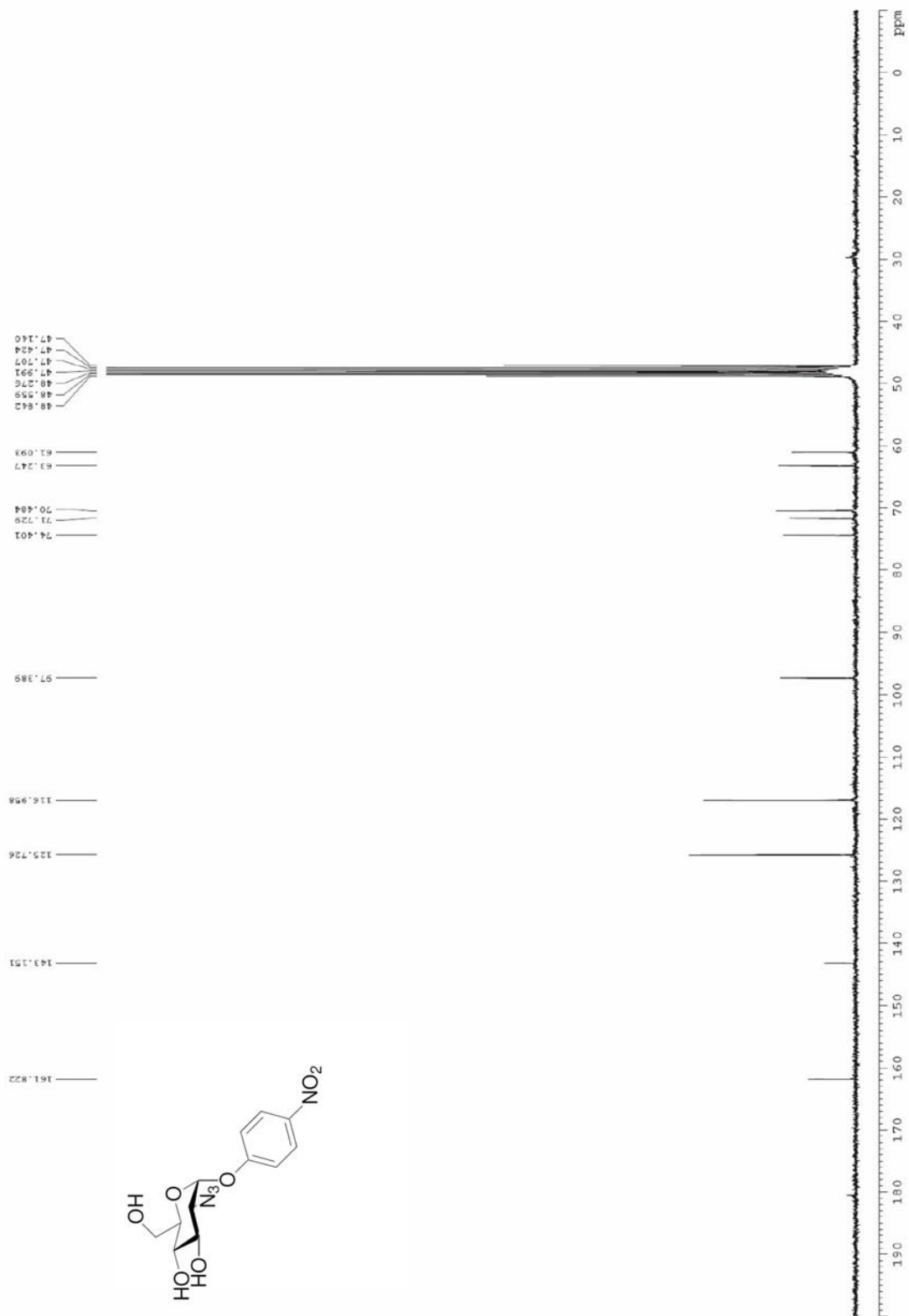

^1H NMR spectrum of (*p*-nitrophenyl) 2,3,4,6-tetra-*O*-acetyl- α -D-galactopyranoside **54a**

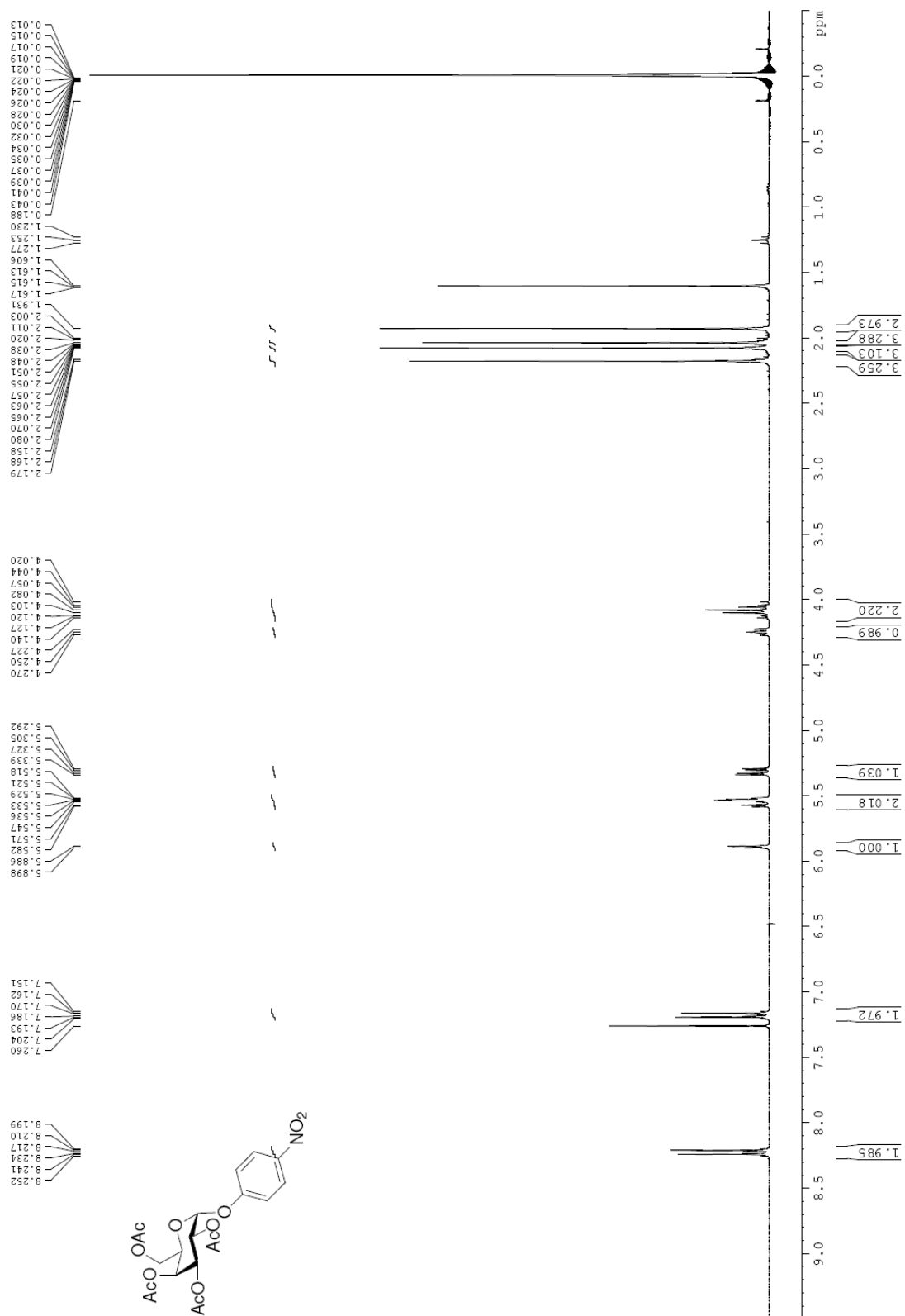

^{13}C NMR spectrum of (*p*-nitrophenyl) 2,3,4,6-tetra-*O*-acetyl- α -D-galactopyranoside **54a**

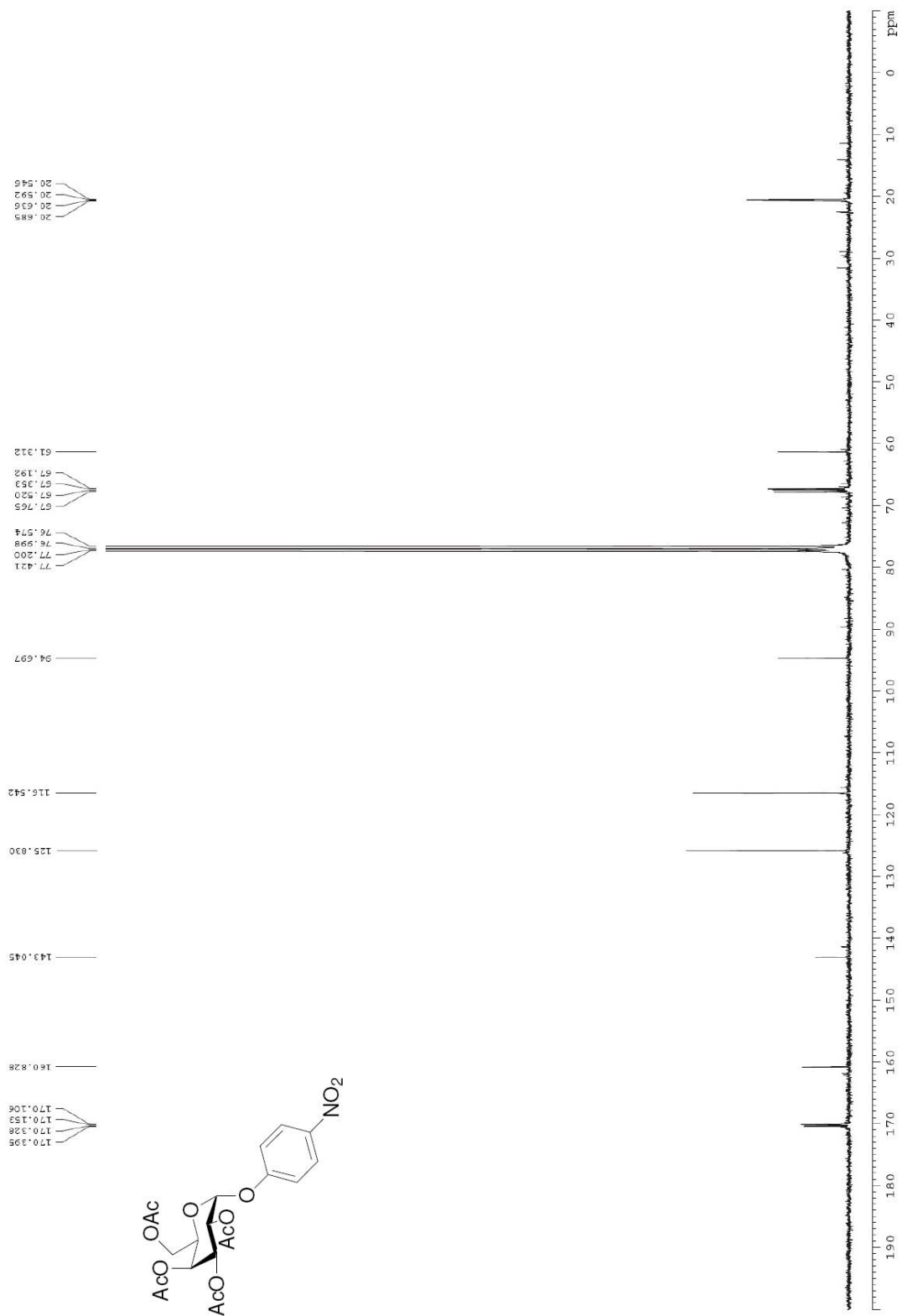

^1H NMR spectrum of (*p*-nitrophenyl) 2,3,4,6-tetra-*O*-acetyl- α -D-galactopyranoside **54 β**

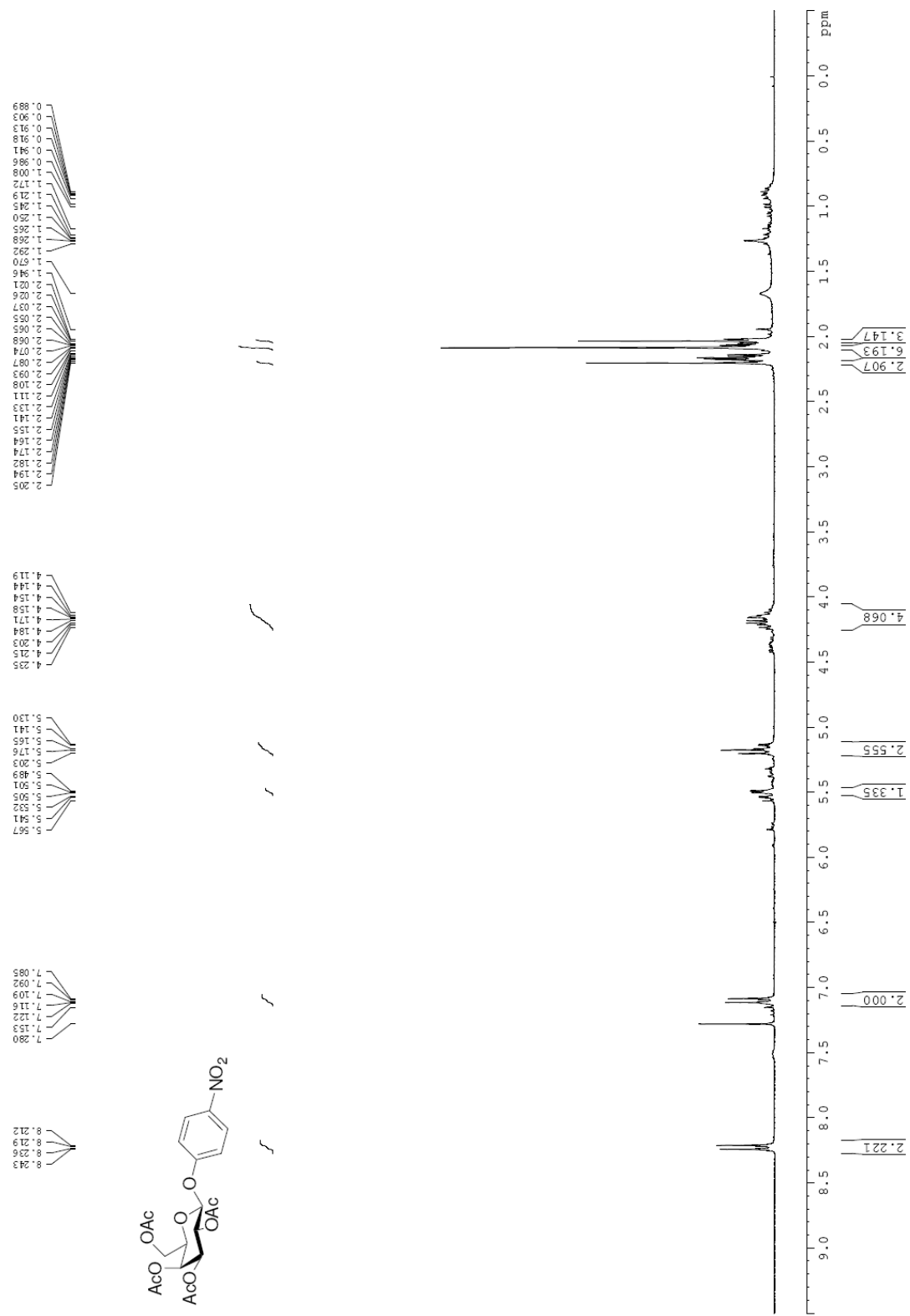

¹H NMR spectrum of (*p*-nitrophenyl) 3,4,6-tetra-*O*-acetyl-2-azido-2-deoxy- α -D-galactopyranoside **55**

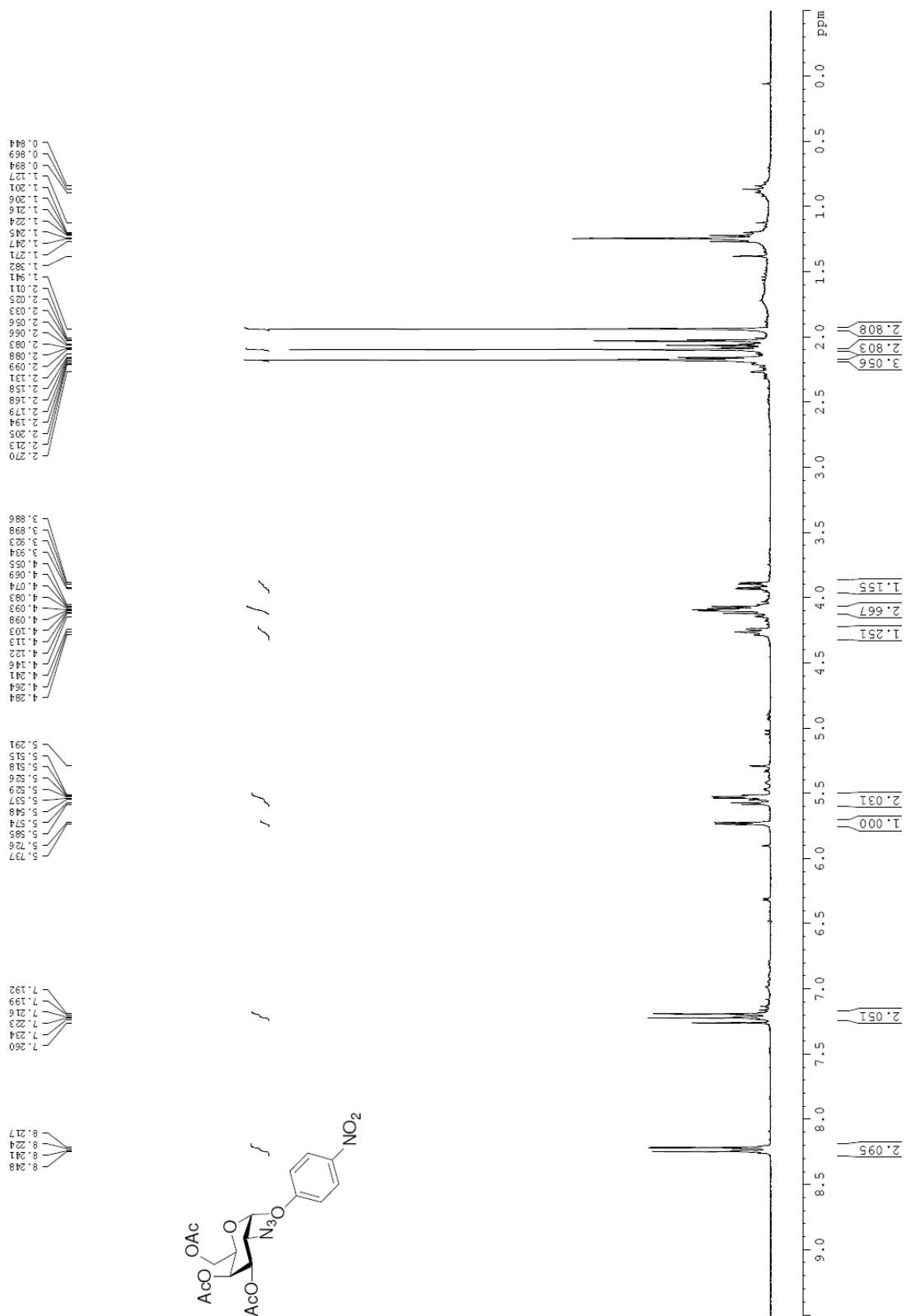

^{13}C NMR spectrum of (*p*-nitrophenyl) 3,4,6-tetra-*O*-acetyl-2-azido-2-deoxy- α -D-galactopyranoside **55**

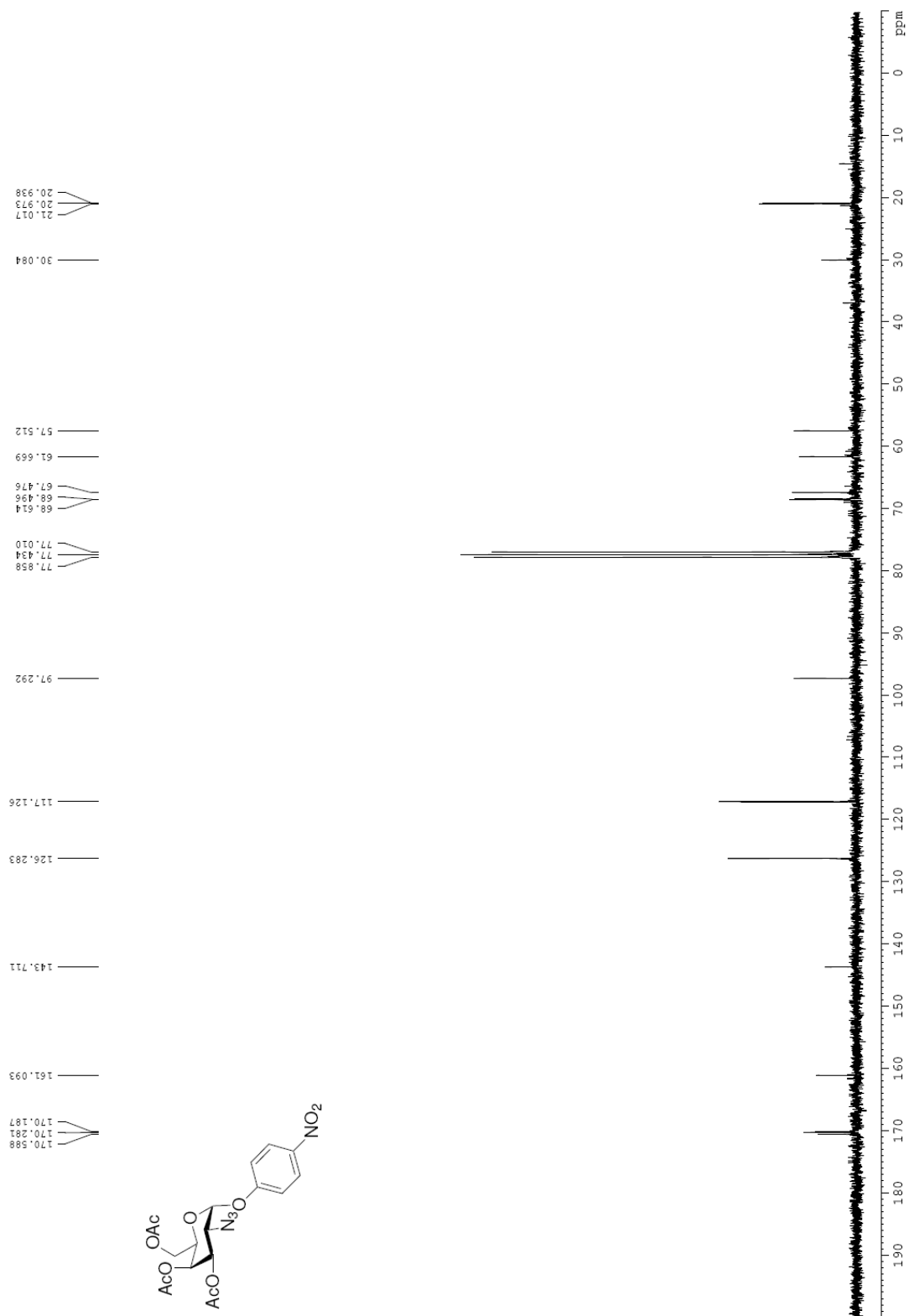

^1H NMR spectrum of (*p*-nitrophenyl) 2,3,4-tri-*O*-acetyl- α -L-rhamnopyranoside **56**

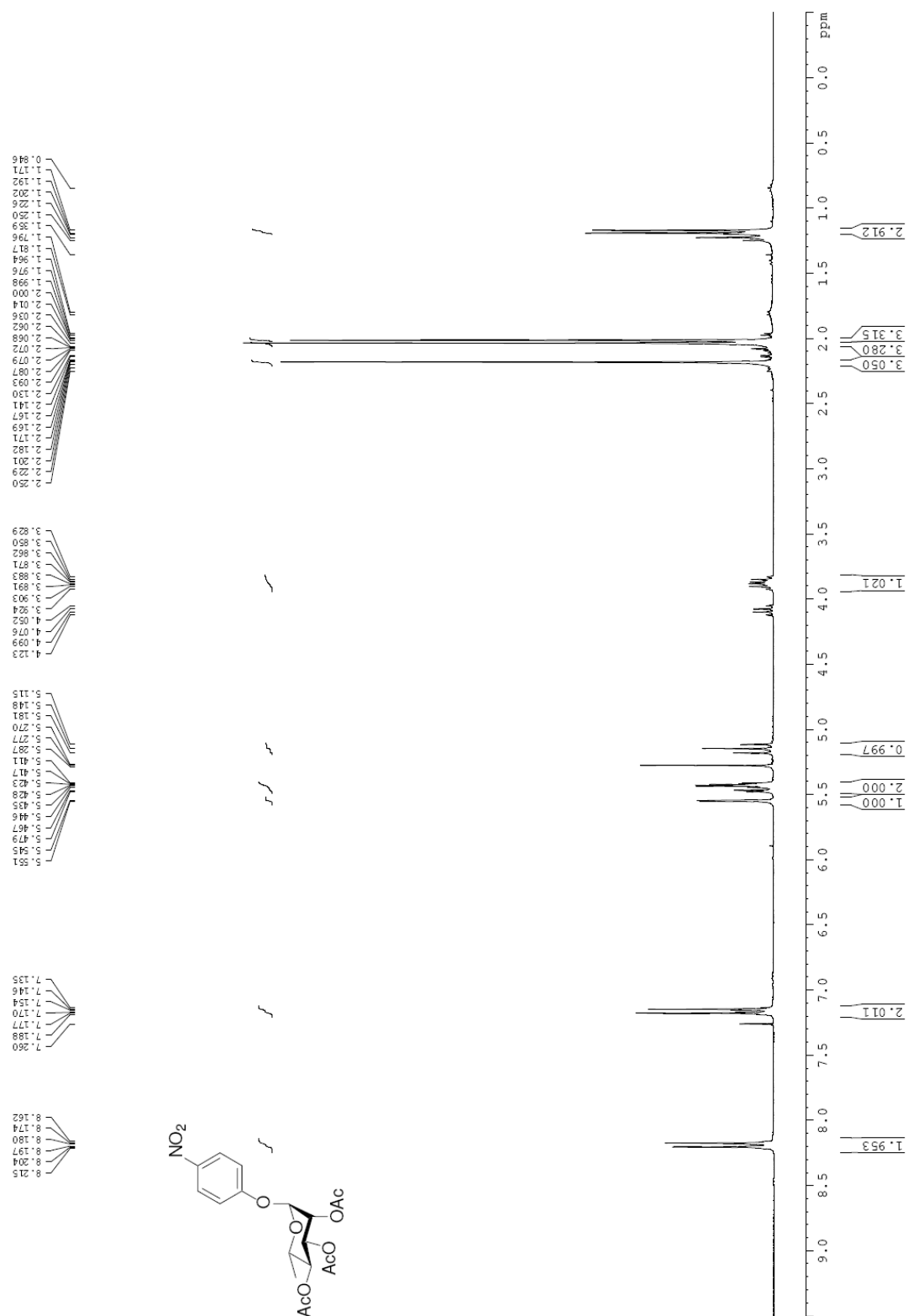

^{13}C NMR spectrum of (*p*-nitrophenyl) 2,3,4-tri-*O*-acetyl- α -L-rhamnopyranoside **56**

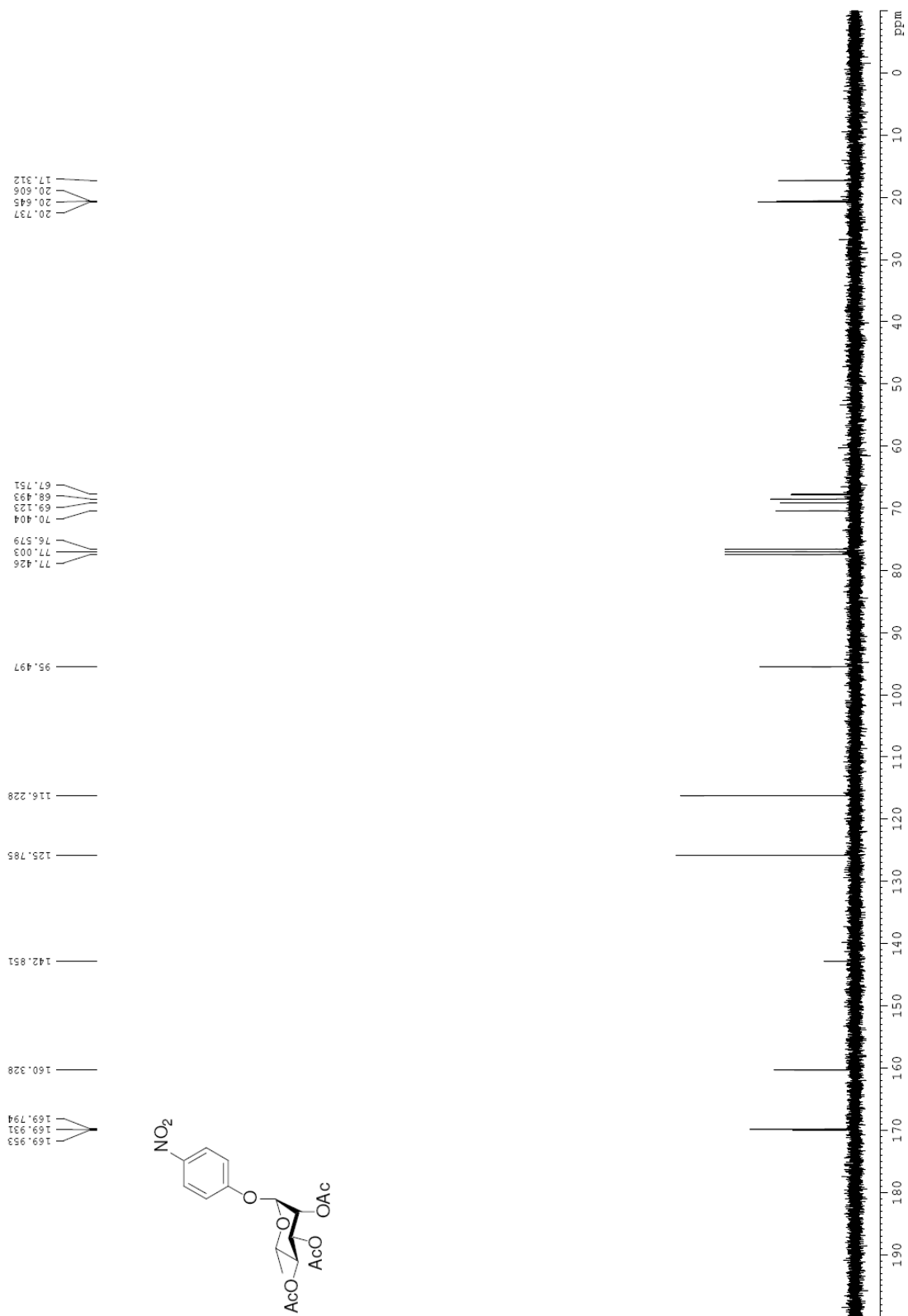

^1H NMR spectrum of (*p*-nitrophenyl) 2,3,4,6-tetra-*O*-acetyl- α -D-mannopyranoside **57**

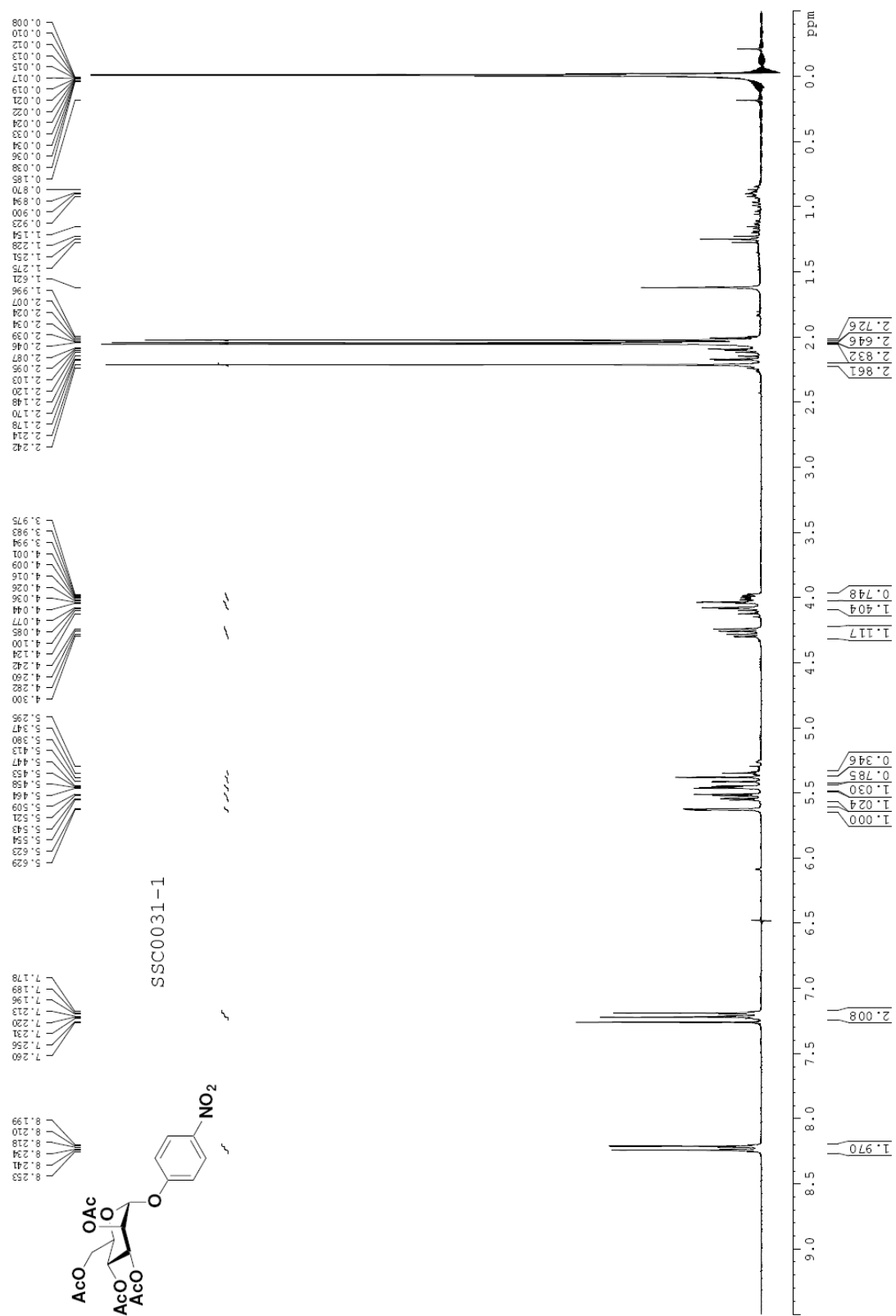

^{13}C NMR spectrum of (*p*-nitrophenyl) 2,3,4,6-tetra-*O*-acetyl- α -D-mannopyranoside **57**

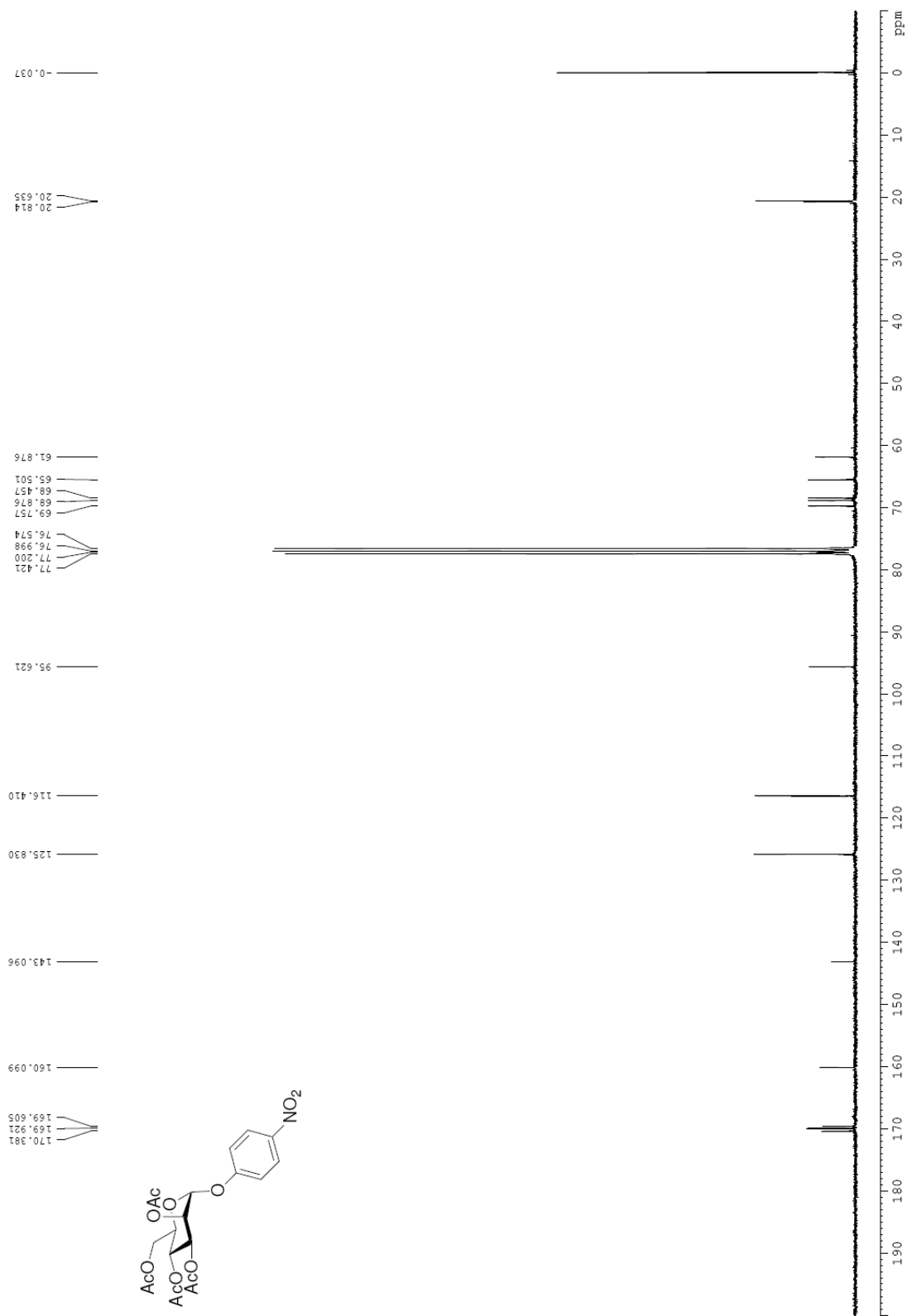

¹H NMR spectrum of (4-methylumbelliferyl) 3,4,6-tri-*O*-acetyl-2-azido-2-deoxy- α -L-galactopyranoside **58**

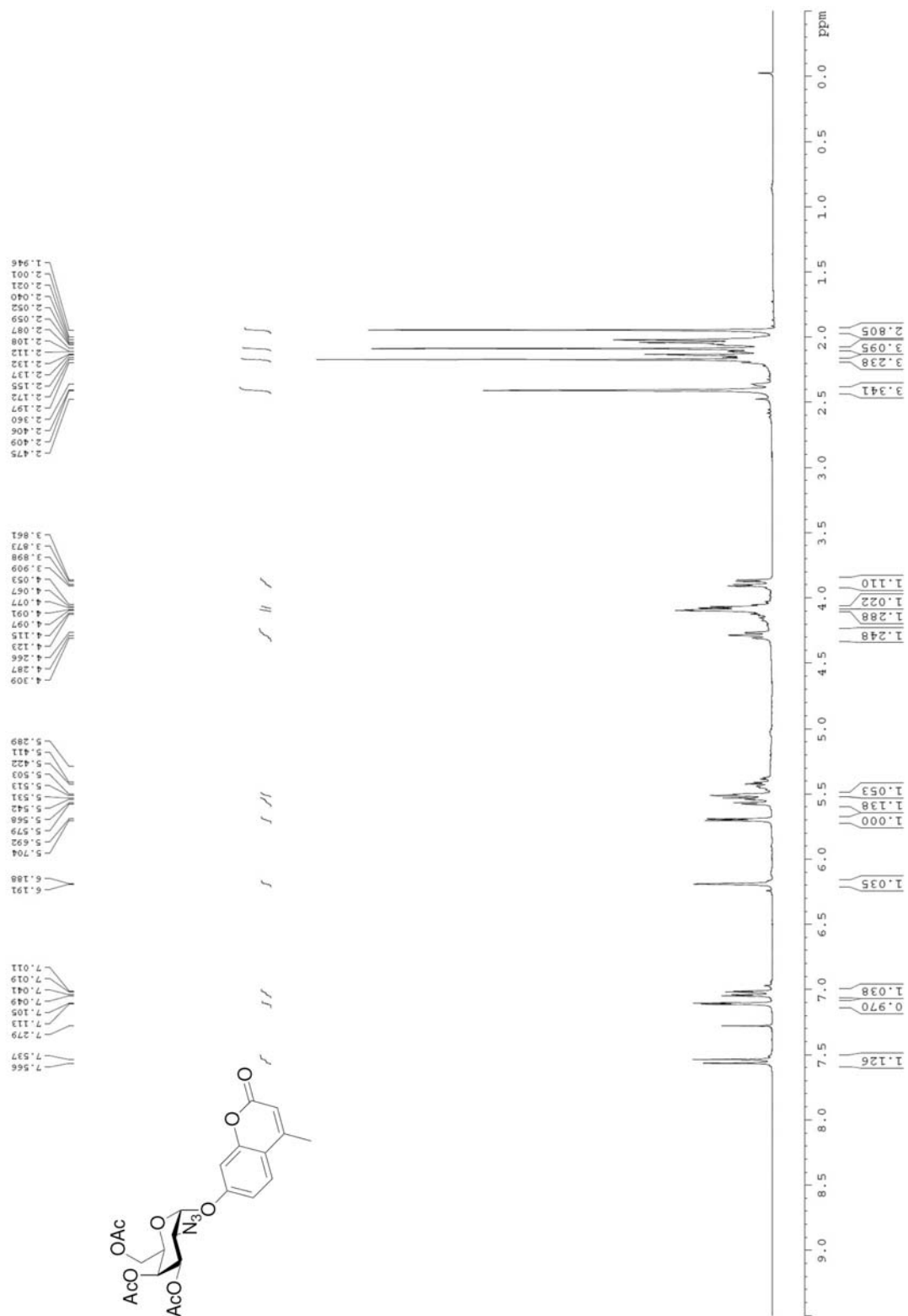

^{13}C NMR spectrum of (4-methylumbelliferyl) 3,4,6-tri-*O*-acetyl-2-azido-2-deoxy- α -L-galactopyranoside **58**

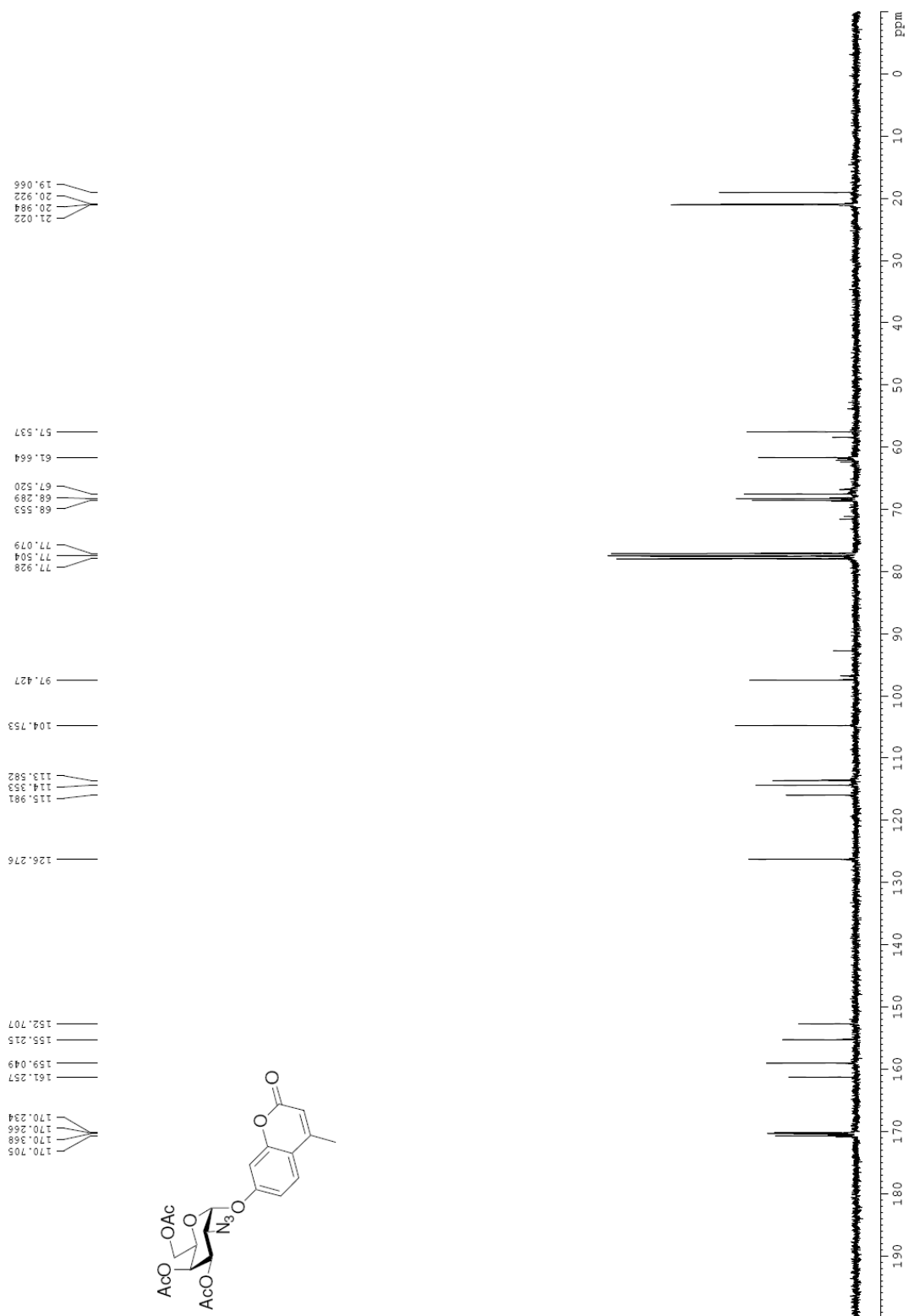

¹H NMR spectrum of (4-methylumbelliferyl)-2-azido-4,6-di-O-benzylidene-2-deoxy-3-O-hydroxyl- α -D-galactopyranoside **59**

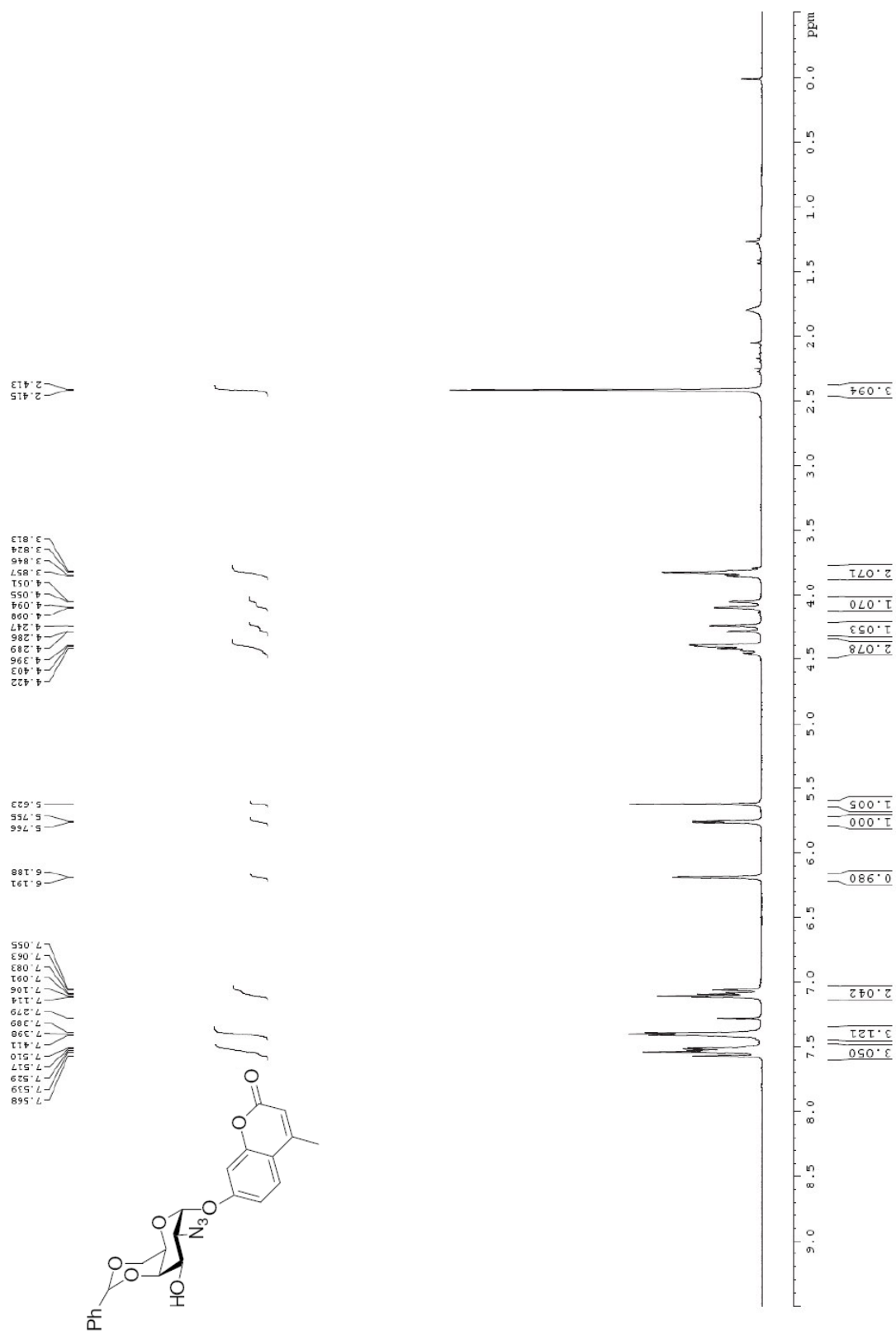

^{13}C NMR spectrum of (4-methylumbelliferyl)-2-azido-4,6-di-*O*-benzylidene-2-deoxy-3-*O*-hydroxyl- α -D-galactopyranoside **59**

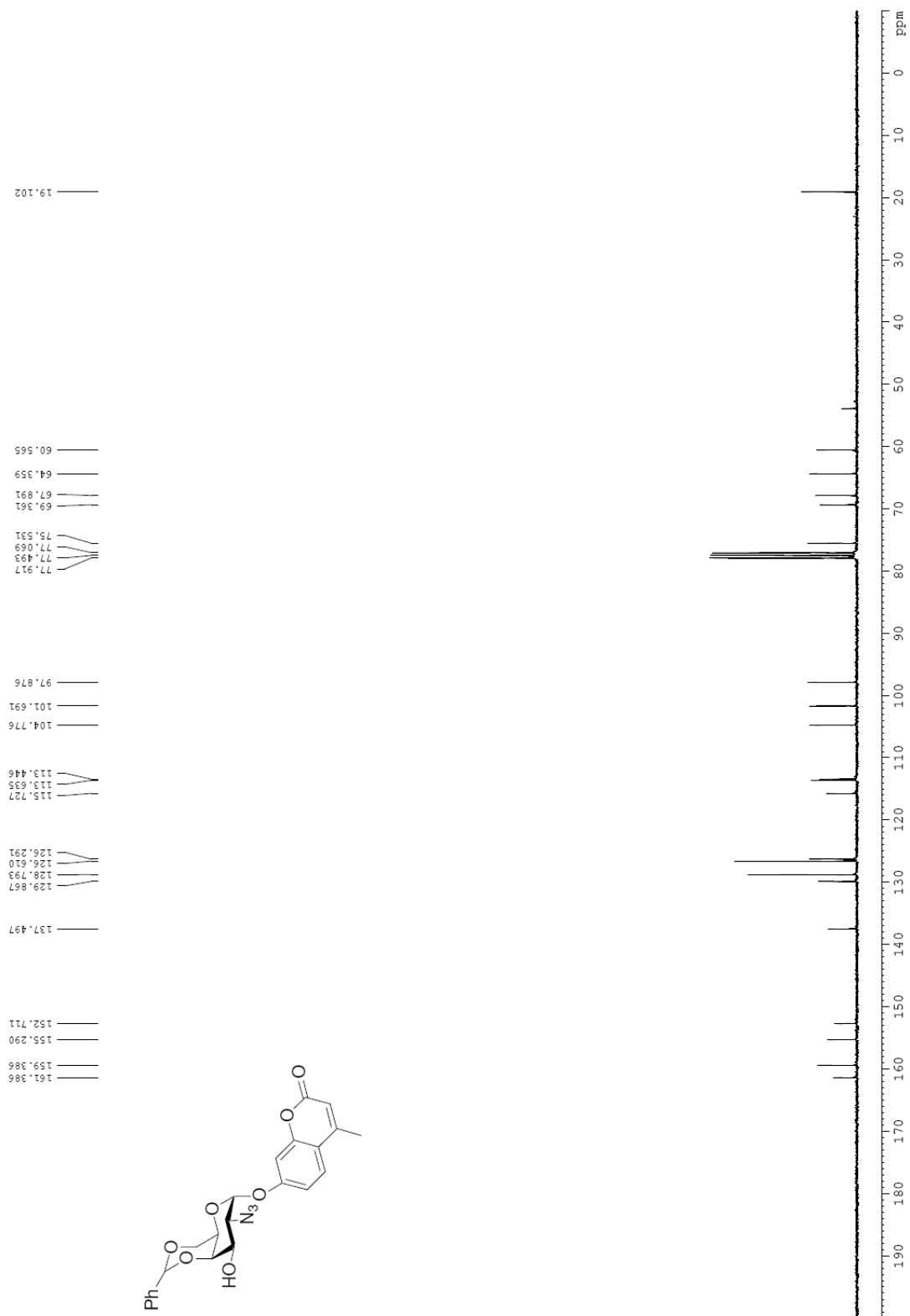

COSY NMR spectrum of (4-methylumbelliferyl)-2-azido-4,6-di-*O*-benzylidene-2-deoxy-3-*O*-hydroxyl- α -D-galactopyranoside **59**

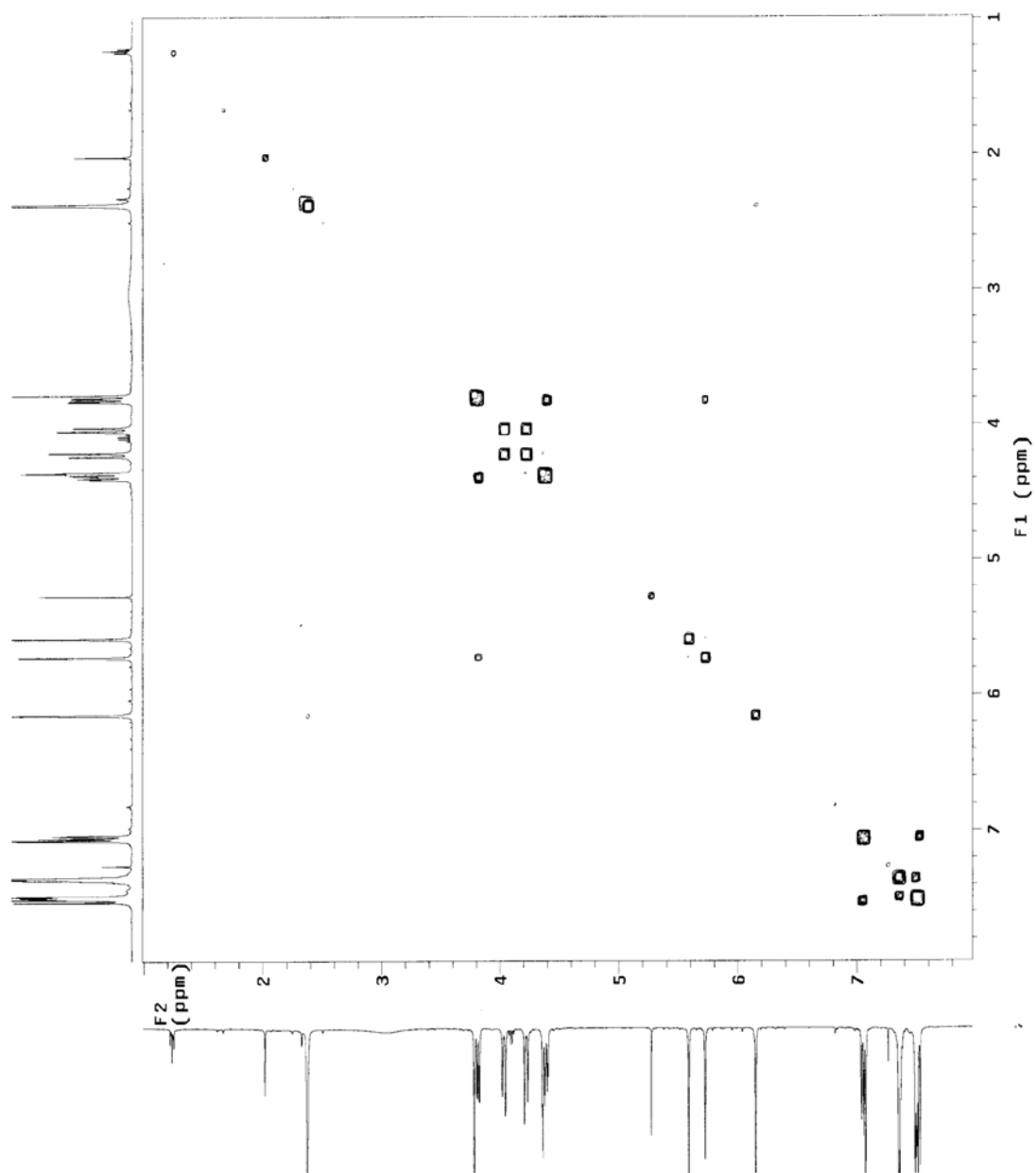

^1H NMR spectrum of (4-methylumbelliferyl)-2-azido-4,6-di-*O*-benzylidene-2-deoxy (2',3',4',6'-tetra-*O*-acetyl- β -D-galactopyranosyl)- α -D-galactopyranoside **60**

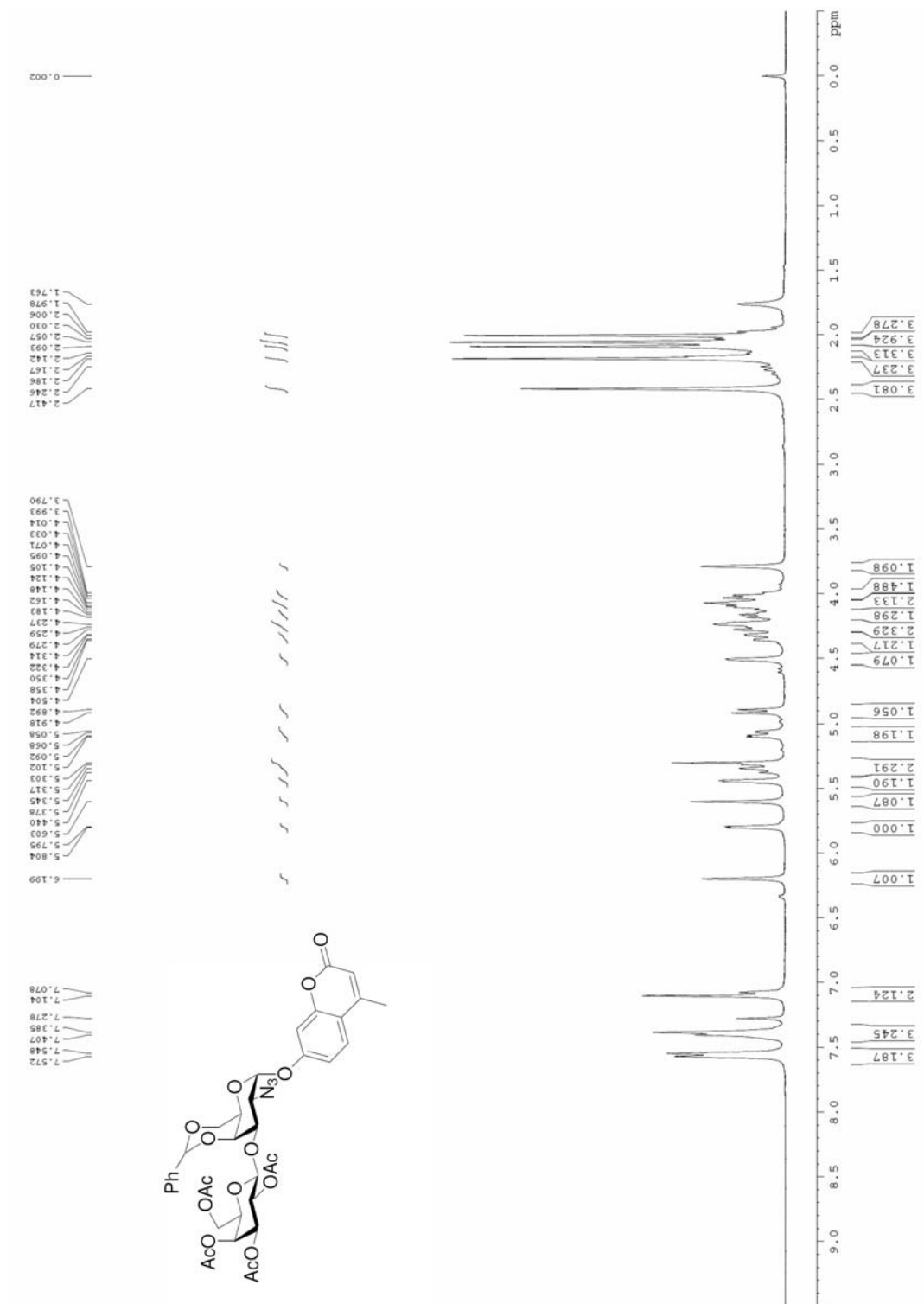

^{13}C NMR spectrum of (4-methylumbelliferyl)-2-azido-4,6-di-*O*-benzylidene-2-deoxy (2',3',4',6'-tetra-*O*-acetyl- β -D-galactopyranosyl)- α -D-galactopyranoside **60**

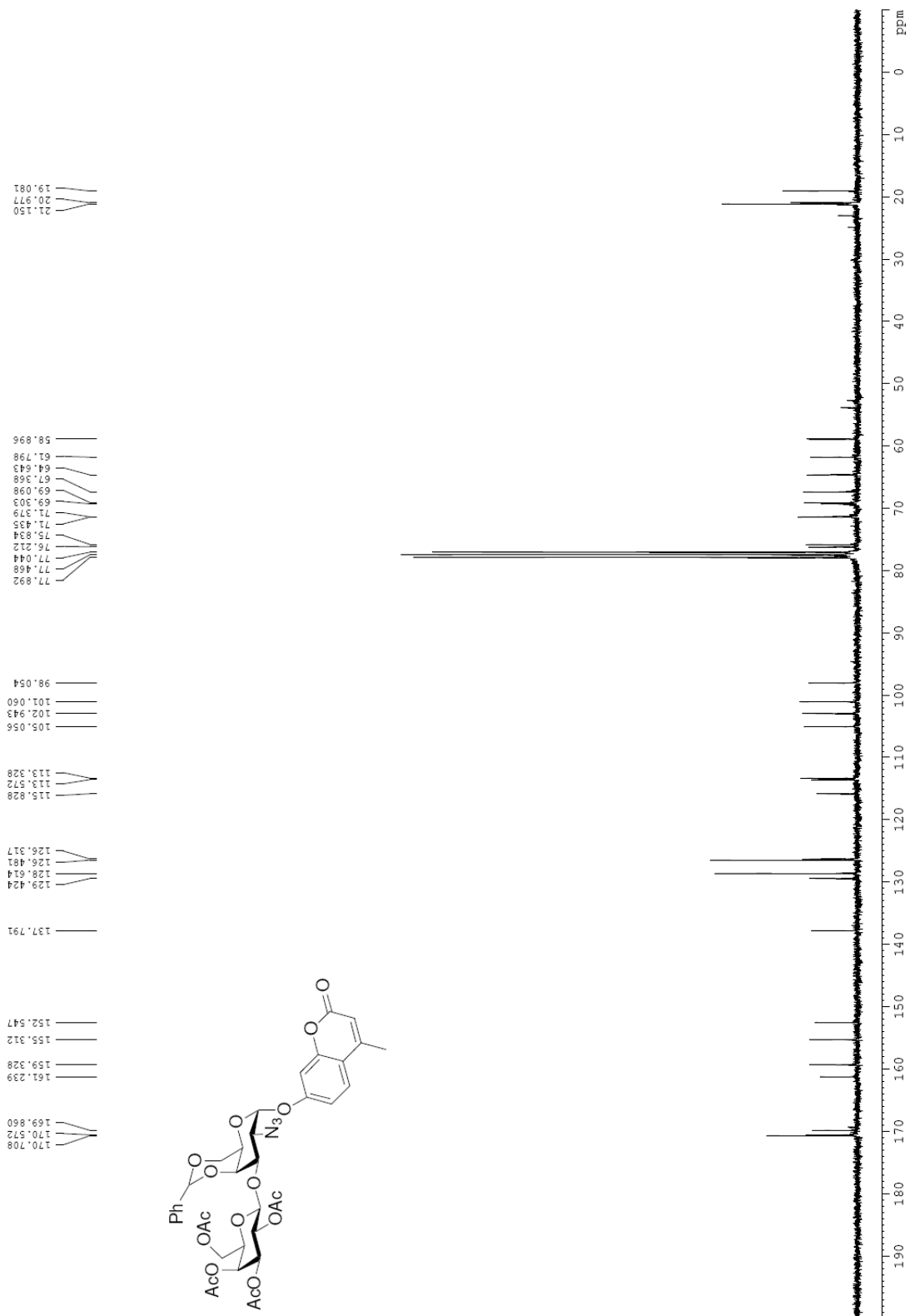

¹H NMR spectrum of (4-methylumbelliferyl)-2-acetamido-2-deoxy-3-(β -D-galactopyranosyl)- α -D-galactopyranoside **24**

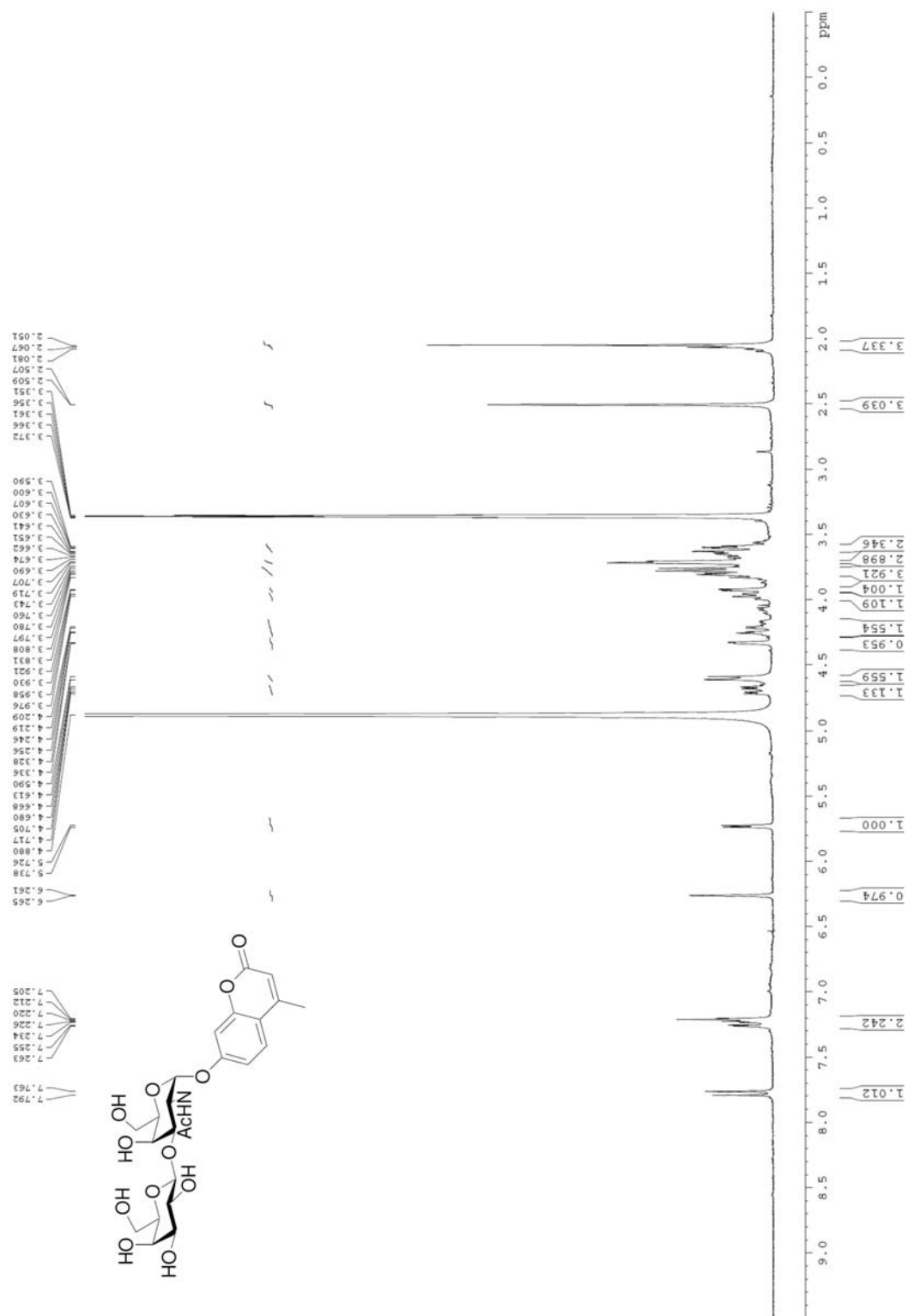

^{13}C NMR spectrum of (4-methylumbelliferyl)-2-acetamido-2-deoxy-3-(β -D-galactopyranosyl)- α -D-galactopyranoside **24**

